



EMC Host Connectivity with QLogic Fibre Channel and iSCSI Host Bus Adapters (HBAs) and Converged Network Adapters (CNAs) in the Windows Environment

P/N 300-001-164
REV 29

EMC Corporation
Corporate Headquarters:
Hopkinton, MA 01748-9103
1-508-435-1000
www.EMC.com

Copyright © 2001–2013 EMC Corporation. All rights reserved.

Published May 2013

EMC believes the information in this publication is accurate as of its publication date. The information is subject to change without notice.

THE INFORMATION IN THIS PUBLICATION IS PROVIDED "AS IS." EMC CORPORATION MAKES NO REPRESENTATIONS OR WARRANTIES OF ANY KIND WITH RESPECT TO THE INFORMATION IN THIS PUBLICATION, AND SPECIFICALLY DISCLAIMS IMPLIED WARRANTIES OF MERCHANTABILITY OR FITNESS FOR A PARTICULAR PURPOSE.

Use, copying, and distribution of any EMC software described in this publication requires an applicable software license.

EMC², EMC, and the EMC logo are registered trademarks or trademarks of EMC Corporation in the United State and other countries. All other trademarks used herein are the property of their respective owners.

For the most up-to-date regulator document for your product line, go to EMC Online Support (<https://support.emc.com>).

Preface.....	11
Chapter 1	Installation and Configuration
How this guide works.....	16
Downloading latest QLogic drivers/firmware/BIOS files.....	16
Installing the adapter	18
Special installation sequence for Stratus ftServers and EMC VNX series or CLARiiON systems.....	19
Matching the adapter with the correct PCI slot	20
Fibre Channel over Ethernet (FCoE)	25
Booting from the external storage array	26
Create a floppy disk with the EMC-approved driver and BIOS	26
Install/upgrade firmware and boot BIOS from DOS.....	27
QLogic Fibre Channel adapter BIOS/boot LUN settings....	28
Verifying array/LUN visibility for boot	53
Installing a RAMDISK under the EFI shell.....	53
Installing the Windows operating system.....	55
Windows 2000/2003 internal or external boot disk installation	55
Windows 2008 internal or external boot disk installation...	63
Windows 2008 Server Core operating system option.....	73
Limitations.....	74
EMC support	74
Installing adapter driver and software utilities.....	76
Pre-installation guidelines.....	76
Driver installation/upgrade	77
Post-installation procedures.....	86

Show SAN	90
FCoE converged network adapter (CNA) procedures.....	91
Overview	91
Installing Fibre Channel BIOS and firmware on a QLogic CNA.....	93
Installing Menlo firmware on a QLogic CNA.....	97
Installing or upgrading the driver and utilities on a QLogic QLE8242 CNA.....	101
Updating adapter firmware on a QLogic QLE8242 CNA.....	105
Configuring QLogic FAST!UTIL 10 GbE iSCSI BIOS/ boot LUN settings for QLE8242 iSCSI adapters.....	117
Establishing connectivity to the storage array	127
Verifying connectivity to the storage array.....	128
Verifying connectivity through QLogic SANSurfer.....	128
Verifying connectivity using the Server Manager.....	130
Installing additional Unisphere/Navisphere Host Agent software	133

Chapter 2 Miscellaneous Planning and Procedures

Zoning and connection planning in a fabric environment.....	136
Installing and configuring the QLogic QLA40xx and QLe40xx iSCSI adapter (TOE).....	137
Using the QLogic iSCSI SANsurfer application to configure iSCSI devices	137
Configuring iSNS settings for QLA4010	140
Bootting from SAN with QLogic QLA40xx and Microsoft Initiator.....	146
Boot-from-SAN configuration restrictions.....	156
Benefits of bootting from the storage array	156
Setting up external boot for IBM BladeCenter server HS40 (8839)	157
Configuring an HS40 BladeCenter server to boot from an external array	157
Blade server restrictions	158
Manually installing the adapter driver – Advanced users.....	159
Where to find the driver	159
Required Windows STORPort updates	159
Migrating Windows 2003 drivers from SCSI to STOR.....	160
Manual driver installation procedure for Windows 2000, 2003, or Windows 2008 hosts.....	160

	Updating the adapter driver in a Windows 2000, 2003, or Windows 2008 hosts	162
	Upgrading to Windows 2003 from Windows 2000.....	165
	Editing the Windows time-out value.....	166
	QLogic advanced utilities	167
	Updating QLogic firmware/BIOS and applying NVRAM settings	167
	Updating the flash BIOS using SANsurfer FC HBA Manager.....	168
	Procedure for replacing a QLogic adapter in Stratus ftServers without rebooting.....	171
	EMC VNX series or CLARiiON storage systems	171
	EMC Symmetrix arrays with device masking enabled	172
	Special instructions for the EMC CLARiiON CX200 series	174
	Set the adapter FC-AL loop ID.....	174
	Direct-connect dual-host clustering configurations.....	176
	QLogic NPIV solution	178
	QLogic FC adapter NPIV solution	178
Chapter 3	Troubleshooting	
	Operating system/driver capabilities and limitations	182
	LUNs.....	182
	Volume sizes	182
	Extended error logging by QLogic drivers.....	184
	Understanding persistent binding.....	185
	Understanding queue depth	188
	Known issues	190
	Problems and solutions	191
	Problem 1.....	191
	Problem 2.....	191
	Problem 3.....	191
	Problem 4.....	192
	Problem 5.....	192
	Problem 6.....	192
	Problem 7.....	193
	Problem 8.....	193
	Problem 9	193
	Event codes from the QLogic STORPort driver.....	194
Appendix A	Third-Party Software	
	QLogic SANsurfer SANblade Manager	196

	Title	Page
1	Installation and configuration overview	17
2	PCI slot types and voltage key locations	21
3	Adapter edge connectors	21
4	PCI Express slots	22
5	PCI Express slots aligned	23
6	QLogic banner	29
7	Main Fast!UTIL options window	30
8	Configuration Settings window	30
9	Adapter Settings window	31
10	Configuration Settings window	31
11	Selectable Boot Settings window	32
12	Select Fibre Channel Device window	33
13	Example of LUN 17 allocated to adapter	34
14	Selectable Boot Settings window	35
15	Warning dialog	35
16	Fast!UTIL Options window	36
17	Typical QLogic BIOS banner screen	36
18	Firmware boot manager menu	40
19	Device mapping table	41
20	Reference to QLogic Fibre Channel driver	42
21	QLogic directory	43
22	Fibre Channel Card Efi utility	44
23	QLogic efutil all upgrade	45
24	Data loaded onto adapter(s) installed in server	46
25	QLogic adapter instances with specific firmware version	47
26	QLogic Fibre Channel drivers	47
27	Driver handle numbers	48
28	Fibre Channel driver configuration utility	49
29	Edit adapter settings	49
30	Connection option	50

31	Example array port WWN and LUN values	51
32	Options set	52
33	Example blkD as array port	52
34	Windows Setup screen with F6 prompt	57
35	Specifying a driver for your adapter	58
36	Adapter selection screen	59
37	Windows setup screen	60
38	Existing partitions	61
39	Windows Boot Manager	64
40	Windows Setup screen	64
41	Windows Install screen	65
42	Windows operating system selection screen	65
43	Microsoft Software License Terms screen	66
44	Windows setup screen	67
45	Load driver screen	67
46	Loading driver screen	68
47	Browse for Folder screen	69
48	Specifying a driver for your adapter	70
49	Windows installation prompt screen	71
50	Install Windows screen	72
51	Server Core installation example	73
52	QLogic SANsurfer driver install wizard	74
53	QLogic SANsurfer adapter utility installation	75
54	Starting SANsurfer utility from the command line	75
55	SANsurfer Driver Install Wizard for Windows	77
56	HBA Configuration Update dialog box	78
57	Select Driver Installation Type dialog box	79
58	SANsurfer driver location dialog box	80
59	SANsurfer installation with version number	81
60	Updating Driver dialog box	82
61	SANsurfer Java agent service message	83
62	Installing Driver dialog box	84
63	Driver Update Completed dialog box	85
64	HBA Configuration update dialog box	86
65	Select HBA dialog box	87
66	Attach Storage dialog box	88
67	Diagnostics results dialog box	89
68	Show SAN tree	90
69	Device Manager	92
70	SANsurfer utility	93
71	Utilities tab	94
72	Open dialog box	95
73	Security Check dialog box	96

74	Flash Update dialog box	96
75	SANsurfer utility	97
76	Utilities tab	98
77	Open dialog box	99
78	Security Check dialog box	100
79	Flash update dialog box	100
80	QConverged Console Driver Install Wizard	101
81	End User License Agreement	102
82	Installation options	103
83	Installation progress	104
84	Installation complete	105
85	QConvergeConsole Installer Introduction window	106
86	Tomcat Port Number Setup window	107
87	Pre-Installation Summary window	108
88	Enable SSL feature dialog box	108
89	Installation Complete window	109
90	QConvergeConsole GUI	110
91	Port Info tab	111
92	Wizards > Flash Update Wizard (SAN)	112
93	SAN Flash Update Wizard, Add localhost	113
94	File Selection window	114
95	Confirm Changes window	115
96	Security Check	115
97	Flash Update Status window	116
98	Finish	117
99	QLogic Fast!UTIL 10 GbE iSCSI BIOS banner	118
100	QLogic Fast!UTIL iSCSI Select Utility page	118
101	Individual adapter configuration options	119
102	Configuration setting details	120
103	Host Adapter Settings	121
104	Initiator IP Settings	122
105	iSCSI Boot Settings	123
106	List of targets connected to the host	124
107	Primary Boot Device Settings	125
108	QLogic Fast!UTIL 10 GbE iSCSI BIOS banner	126
109	SANsurfer icon	128
110	Connect to the host	129
111	SANsurfer, SANsurfer FC HBA manager	130
112	Server Manager window: Storage controllers pane	131
113	Server Manager window: Disk drives pane	132
114	SANsurfer iSCSI HBA Manager, connect to host	138
115	SANsurfer iSCSI HBA Manager, HBA Options	139
116	SANsurfer iSCSI HBA Manager, HBA Options, Firmware tab	141

117	Download Firmware dialog box	142
118	SANsurfer iSCSI HBA Manager, HBA Options, BIOS tab	143
119	SANsurfer iSCSI HBA Manager, Target Settings tab	143
120	SANsurfer iSCSI HBA Manager, Target Settings, IP Address dialog ..	143
121	Authentication Configuration, CHAP tab	144
122	SANsurfer iSCSI HBA Manager, Information tab	145
123	Utilities tabbed page	169
124	Reconfigure the adapter jumper	177
125	N_Port ID sharing	178
126	Original configuration before the reboot	187
127	Host after the rebooted	187

	Title	Page
1	EMC-supported QLogic adapters	23
2	Pre-configured parameters for 1 and 2 Gb/s	37
3	Pre-configured parameters for 4 Gb/s	38
4	Pre-configured parameters for 8 Gb/s and 16 Gb/s	39
5	Blade servers/QLogic software support matrix	158

As part of an effort to improve and enhance the performance and capabilities of its product line, EMC from time to time releases revisions of its hardware and software. Therefore, some functions described in this document may not be supported by all revisions of the software or hardware currently in use. For the most up-to-date information on product features, refer to your product release notes.

Audience This guide is intended for customers who need to install an EMC-approved QLogic host bus adapter (HBA) or converged network adapter (CNA) into a Windows host environment or to configure the Windows host for connection to an EMC storage array.

Related documentation Related documents, which can be found on <https://support.emc.com>, include:

- ◆ *EMC Host Connectivity Guide for Windows*
- ◆ EMC Unisphere documentation
- ◆ EMC Navisphere documentation
- ◆ *EMC ControlCenter Navisphere Host Agent and CLI for Windows 2000 and NT Version 6.X Installation Guide*
- ◆ *Storage-System Host Utilities for Windows 2000 and NT Administrator's Guide*
- ◆ *PowerPath for Windows Installation And Administration Guide*

IMPORTANT

Always consult the *EMC Support Matrix*, available through E-Lab Interoperability Navigator at: <http://elabnavigator.EMC.com>, under the **PDFs and Guides** tab, for the most up-to-date information.

Conventions used in this guide

EMC uses the following conventions for notes, cautions, and warnings.

Note: A note presents information that is important, but not hazard-related.

IMPORTANT

An important notice contains information essential to operation of the software.

Typographical conventions

EMC uses the following type style conventions in this document:

Normal	Used in running (nonprocedural) text for: <ul style="list-style-type: none"> Names of interface elements (such as names of windows, dialog boxes, buttons, fields, and menus) Names of resources, attributes, pools, Boolean expressions, buttons, DQL statements, keywords, clauses, environment variables, filenames, functions, utilities URLs, pathnames, filenames, directory names, computer names, links, groups, service keys, file systems, notifications
Bold	Used in running (nonprocedural) text for: <ul style="list-style-type: none"> Names of commands, daemons, options, programs, processes, services, applications, utilities, kernels, notifications, system call, man pages Used in procedures for: <ul style="list-style-type: none"> Names of interface elements (such as names of windows, dialog boxes, buttons, fields, and menus) What user specifically selects, clicks, presses, or types
<i>Italic</i>	Used in all text (including procedures) for: <ul style="list-style-type: none"> Full titles of publications referenced in text Emphasis (for example a new term) Variables
Courier	Used for: <ul style="list-style-type: none"> System output, such as an error message or script URLs, complete paths, filenames, prompts, and syntax when shown outside of running text

Courier bold	Used for: <ul style="list-style-type: none"> • Specific user input (such as commands)
<i>Courier italic</i>	Used in procedures for: <ul style="list-style-type: none"> • Variables on command line • User input variables
< >	Angle brackets enclose parameter or variable values supplied by the user
[]	Square brackets enclose optional values
	Vertical bar indicates alternate selections - the bar means “or”
{ }	Braces indicate content that you must specify (that is, x or y or z)
...	Ellipses indicate nonessential information omitted from the example

Where to get help

EMC support, product, and licensing information can be obtained on the EMC Online Support site as described next.

Note: To open a service request through the EMC Online Support site, you must have a valid support agreement. Contact your EMC sales representative for details about obtaining a valid support agreement or to answer any questions about your account.

Product information

For documentation, release notes, software updates, or for information about EMC products, licensing, and service, go to the EMC Online Support site (registration required) at:

<https://support.EMC.com>

Technical support

EMC offers a variety of support options.

Support by Product — EMC offers consolidated, product-specific information on the Web at:

<https://support.EMC.com/products>

The Support by Product web pages offer quick links to Documentation, White Papers, Advisories (such as frequently used Knowledgebase articles), and Downloads, as well as more dynamic content, such as presentations, discussion, relevant Customer Support Forum entries, and a link to EMC Live Chat.

EMC Live Chat — Open a Chat or instant message session with an EMC Support Engineer.

eLicensing support

To activate your entitlements and obtain your Symmetrix license files, visit the Service Center on <https://support.EMC.com>, as directed on your License Authorization Code (LAC) letter e-mailed to you.

For help with missing or incorrect entitlements after activation (that is, expected functionality remains unavailable because it is not licensed), contact your EMC Account Representative or Authorized Reseller.

For help with any errors applying license files through Solutions Enabler, contact the EMC Customer Support Center.

If you are missing a LAC letter, or require further instructions on activating your licenses through the Online Support site, contact EMC's worldwide Licensing team at licensing@emc.com or call:

- ◆ North America, Latin America, APJK, Australia, New Zealand: SVC4EMC (800-782-4362) and follow the voice prompts.
- ◆ EMEA: +353 (0) 21 4879862 and follow the voice prompts.

We'd like to hear from you!

Your suggestions will help us continue to improve the accuracy, organization, and overall quality of the user publications. Send your opinions of this document to:

techpubcomments@emc.com

This chapter describes the procedures for installing an EMC-approved QLogic adapters into a Microsoft Windows host environment and configuring the Windows host for connection to an EMC storage array over Fibre Channel.

Note: Review the *EMC Support Matrix* for the latest information on approved adapters and drivers.

◆ How this guide works	16
◆ Installing the adapter.....	18
◆ Fibre Channel over Ethernet (FCoE)	25
◆ Booting from the external storage array	26
◆ Installing the Windows operating system.....	55
◆ Windows 2008 Server Core operating system option.....	73
◆ Installing adapter driver and software utilities	76
◆ FCoE converged network adapter (CNA) procedures	91
◆ Establishing connectivity to the storage array.....	127
◆ Verifying connectivity to the storage array	128
◆ Installing additional Unisphere/Navisphere Host Agent software	133

How this guide works

In an effort to simplify the installation and configuration of QLogic Fibre Channel adapters, this guide follows a simple flow chart, as shown in [Figure 1 on page 17](#), that guides you through the necessary procedures to connect your Windows server to EMC storage arrays. Tips on planning, miscellaneous procedures, and troubleshooting information are located in [Chapter 2, "Miscellaneous Planning and Procedures,"](#) and [Chapter 3, "Troubleshooting."](#)

This document will guide you through the following steps:

1. ["Installing the adapter" on page 18](#)
2. ["Bootting from the external storage array" on page 26:](#)
 - a. If *not* installing an IA-64 or EFI-based server:
 - ["Create a floppy disk with the EMC-approved driver and BIOS" on page 26.](#)
 - ["Install/upgrade firmware and boot BIOS from DOS" on page 27.](#)
 - ["QLogic Fibre Channel adapter BIOS/boot LUN settings" on page 28.](#)
 - ["Verifying array/LUN visibility for boot" on page 53.](#)
 - b. If installing an IA-64 or EFI-based server:
 - ["Installing a RAMDISK under the EFI shell" on page 53](#)
3. ["Installing the Windows operating system" on page 55.](#)
4. ["Installing adapter driver and software utilities" on page 76.](#)
5. ["Verifying connectivity to the storage array" on page 128.](#)

Downloading latest QLogic drivers/firmware/BIOS files

Throughout this document, there are references to updated files from QLogic. All of the versions included on the QLogic CD packaged with your adapter are current as of this documents release. However, there may be updates to these files that may be necessary to download. For these, use the QLogic website, <http://www.qlogic.com>. From the main page on the QLogic website, click **Downloads** on the top of the page. On the resulting support page, click the **EMC** link under the OEM Models section. On the resulting page, click the **EMC Array** category for your storage array.

On the resulting EMC Approved Software page, it is possible to download the most recent EMC-approved drivers and BIOS files as well as documentation and helpful software tools.

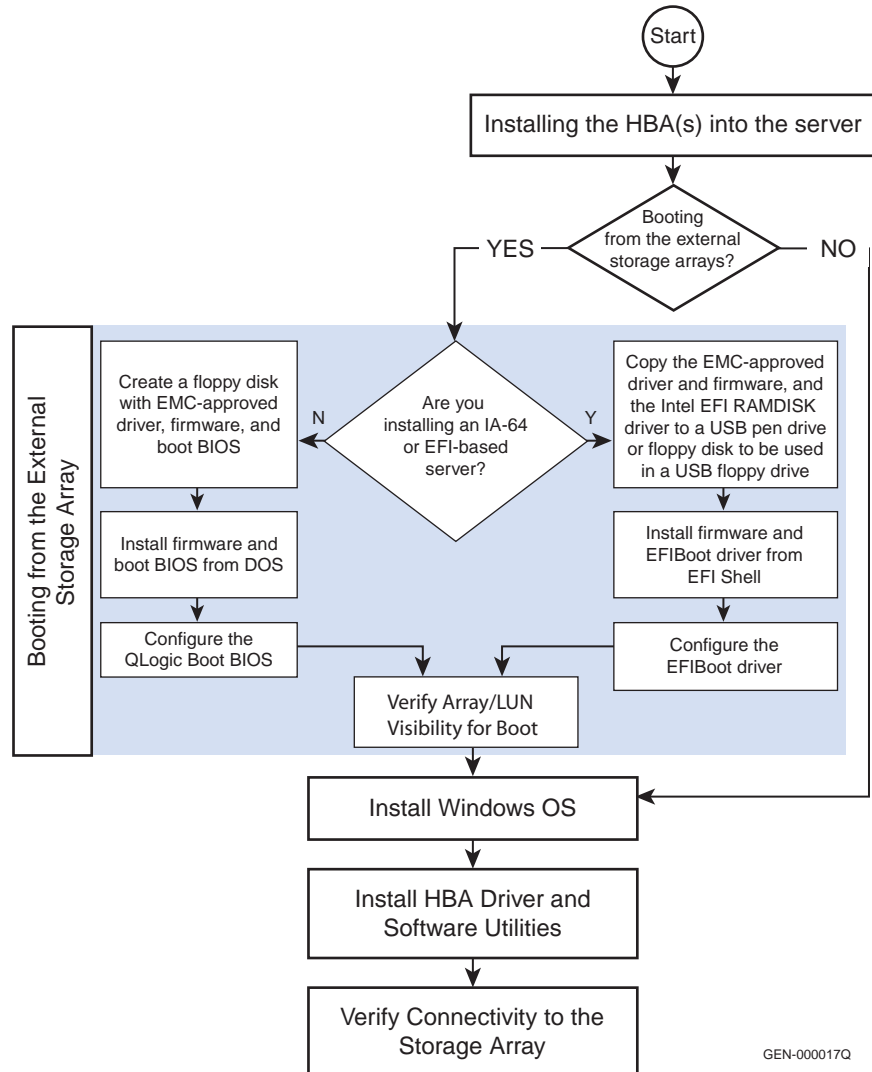

Figure 1 Installation and configuration overview

Installing the adapter

Follow the instructions included with your adapter. The adapter installs into a single slot.

To connect the cable to the adapter:

1. (Optical cable only) Remove the protective covers on each fiber-optic cable.
2. Plug one end of the cable into the connector on the adapter as shown in the appropriate figure in this step. (The hardware might be rotated 90 degrees clockwise from the orientation shown.)
 - Fibre Channel adapter connectivity options include copper cable with DB9 connector, SC optical, and LC optical cable, as shown next.
 - Copper cable with DB9 connector:

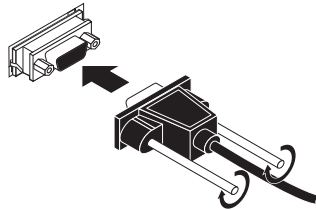

- SC optical cable:

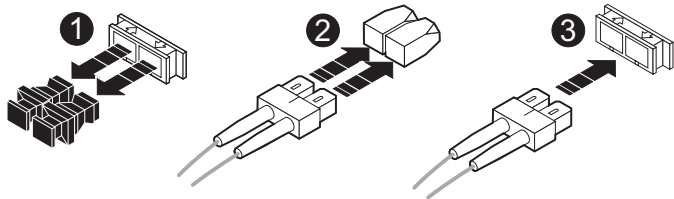

- LC optical cable:

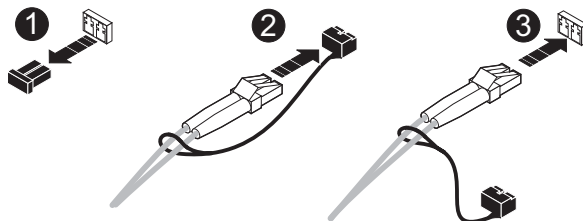

- Fibre Channel over Ethernet CNA connectivity options include LC optical and SFP+, shown next.

- LC optical cable:

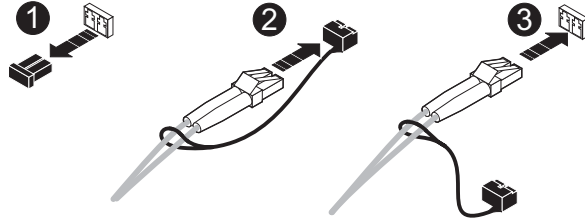

- SFP+ (Twinax cable)



3. Plug the other end of the cable into a connector on the storage system or a hub/switch port.
4. Label each cable to identify the adapter and the storage/switch/hub port to which it connects.
5. After connecting all adapters in the server, power up the server.

Special installation sequence for Stratus ftServers and EMC VNX series or CLARiiON systems

A specific installation sequence is required when installing QLogic adapters with the Stratus ft Servers and EMC® VNX™ series and CLARiiON® storage. Failure to follow this sequence may result in a STOP: 0X0000007B bugcheck error when booting the Stratus server

for the first time when connected to EMC VNX series or CLARiiON storage.

With the Stratus ftServer, if the adapter detects EMC VNX series or CLARiiON targets but no accessible LUNs, it prevents the Stratus server from booting. In this configuration, the Stratus ftServer attempts to boot from the array, instead of booting from the internal boot drive.

To avoid this issue before storage is correctly assigned, either boot the Stratus ftServer before connecting the fibre cables to the adapters or, if connected to a fabric, disable the adapter ports on the switch before booting the ftServer.

After the system boots, connect the cables or re-enable the switch ports. Verify the adapters are logged in to the EMC VNX series or CLARiiON system; then stop and restart the Unisphere™/Navisphere® agent on the ftServer host. This will register the adapters with the VNX series or CLARiiON system and allow the adapter to properly detect the available LUNs.

Matching the adapter with the correct PCI slot

When choosing an adapter for your server, it is important to know which adapter is compatible with your server's PCI/PCI-X/PCI Express slots. Certain adapter models have specific voltage requirements or physical limitations that allow them to only work in specific slots.

Servers today have several different bus slot types for accepting adapters. PCI, PCI-X, PCI-X 2.0, and PCI-Express.

PCI slots can be 32-bit and 64-bit (denoted by their 124-pin or 188-pin connectors). These slots have plastic "keys" that prevent certain adapters from fitting into them. These keys work with the cutout notches in the adapter edge connector so that only compatible adapters will fit into them. This is done because of the voltage characteristics of the adapter. Inserting a 3.3v adapter into a 5v slot would cause severe damage to both the adapter and the server. Therefore, the slot keys denote the type of voltage provided by the slot and effectively prevent a voltage incompatible adapter from being inserted.

Figure 2 shows how PCI slots will appear with their keys and what type of voltage is provided for each slot type.

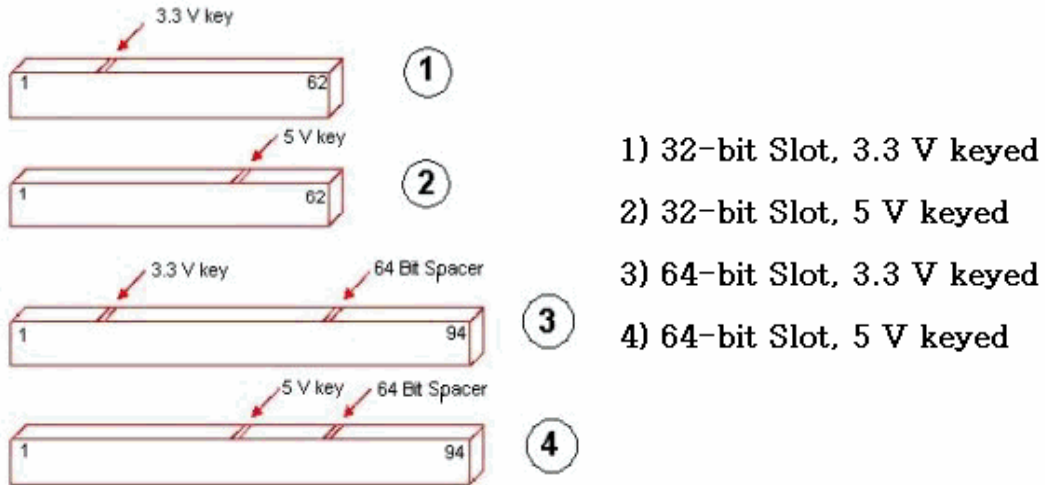

Figure 2 PCI slot types and voltage key locations

Figure 3 on page 21 shows the adapter edge connectors compatible with the PCI slots shown in Figure 1 on page 17. Note adapter #5 which shows a universal adapter edge connector. Universal adapters are compatible with both 3.3v and 5v PCI slots.

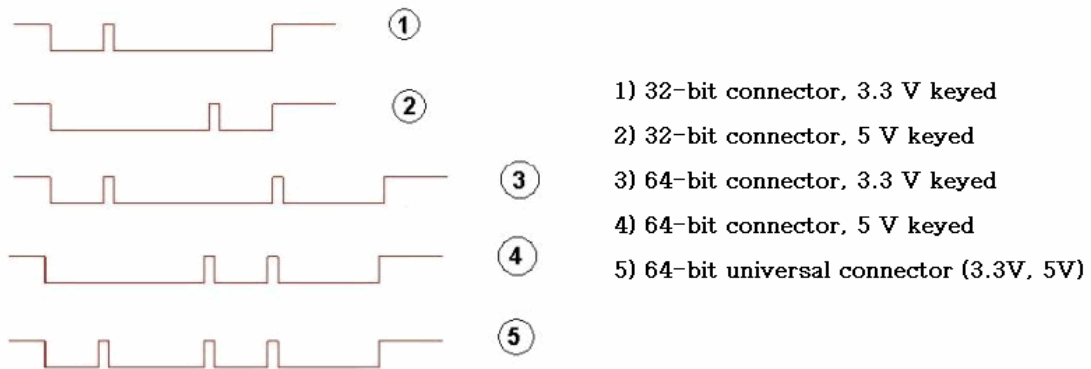

Figure 3 Adapter edge connectors

PCI-X (or PCI Extended) slots increase the speed that data travels over the bus. PCI-X slots appear identical to a 64-Bit PCI slot keyed for 3.3v. (Refer to number 3 in [Figure 2 on page 21](#) and [Figure 3 on page 21](#).) PCI-X slots are backwards compatible with 3.3v PCI adapters and universal adapters. Inserting standard PCI adapters into PCI-X slots will lower the bus speed, however, as they cannot take advantage of the improved performance.

PCI-X 2.0 is the next generation of PCI-X buses. PCI-X 2.0 increases the bus speed providing more performance for adapters. PCI-X 2.0 slots also appear identical to a 64-bit PCI slot keyed for 3.3v. (Refer to number 3 in [Figure 2](#) and [Figure 3](#).) PCI-X 2.0 is also fully backward-compatible with 3.3v PCI and PCI-X.

PCI Express (sometimes noted as PCIe) is a new bus type that uses the existing PCI model, but implements it in a faster, serial protocol. Because of the serial way it transmits data, the PCI Express bus slot can be different sizes depending on the throughput it supports. PCI Express slot speeds are expressed in "lanes" and are normally shown as x1, x4, x8, and x16. Each type of slot are different lengths ([Figure 4](#)) and adapter edge connectors will also have varying lengths depending on how many lanes they require for throughput. Because of how PCI Express slots are keyed, an x1 adapter can be inserted in all 4 slot types as the adapter will negotiate with the slot to determine the highest mutually supported number of lanes. However, an adapter requiring x16 lanes will not fit into a smaller slot.

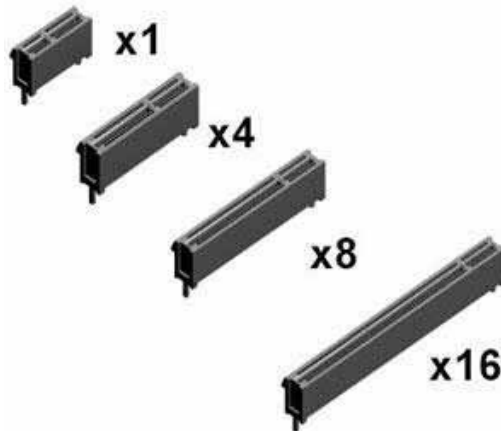

Figure 4 PCI Express slots

Figure 5 shows x1, x4, and x16 lane slots aligned on a mainboard. You can see how the slots are keyed so that low-lane adapters can fit into larger slots.

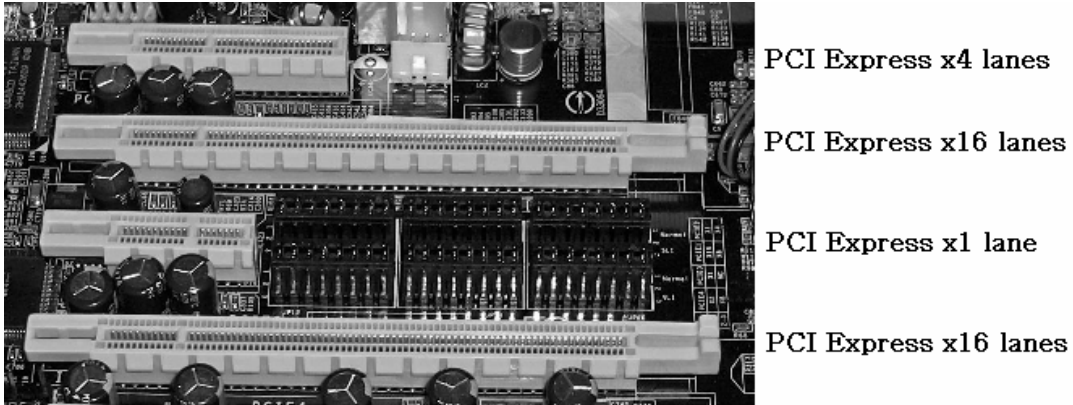

Figure 5 PCI Express slots aligned

QLogic offers adapters for each bus/slot type available. [Table 1](#) shows each of the EMC-supported QLogic adapters, and their respective slot requirements. Be sure to consult both your server user guide and QLogic to insure that the adapter you want to use is compatible with your server's bus.

Table 1 EMC-supported QLogic adapters (page 1 of 2)

Adapter	Protocol	PCI spec	BUS length	Power	Slot key
QLA2200F	FC	PCI 2.1	64-bit	3.3V, 5V	Universal
QLA200	FC	PCI-X 1.0a & PCI 2.2	32-bit	3.3V, 5V	3.3V
QLA210	FC	PCI-X 1.0a & PCI 2.2	32-bit	3.3V	3.3V
QLA2310F	FC	PCI-X 1.0a & PCI 2.2	64-bit	3.3V, 5V	Universal
QLA2340LF	FC	PCI-X 1.0a & PCI 2.2	64-bit	3.3V, 5V	Universal
QLA2342LF	FC	PCI-X 1.0a & PCI 2.2	64-bit	3.3V, 5V	Universal
QLE2360	FC	PCI Express	x4 lane	3.3V	n/a
QLE2362	FC	PCI Express	x4 lane	3.3V	n/a
QLA2460	FC	PCI-X 2.0a & PCI 2.3	64-bit	3.3V	3.3V

Table 1 EMC-supported QLogic adapters (page 2 of 2)

Adapter	Protocol	PCI spec	BUS length	Power	Slot key
QLA2462	FC	PCI-X 2.0a & PCI 2.3	64-bit	3.3V	3.3V
QLE2460	FC	PCI Express	x4 lane	3.3V	n/a
QLE2462	FC	PCI Express	x4 lane	3.3V	n/a
QLE220	FC	PCI Express	x4 lane	3.3V	n/a
QLE2560	FC	PCI Express	x4 lane	3.3V	n/a
QLE2562	FC	PCI Express	x4 lane	3.3V	n/a
QLE8042	FCoE	PCI Express	x8 lane	3.3V	n/a
QLE8140/8142	FCoE	PCI Express	x4/x8 lane	3.3V	n/a
QLE8150/8152	FCoE	PCI Express	x4/x8 lane	3.3V	n/a
QLE8242-CU	FCoE	PCI Express	x4/x8 lane	3.3V	n/a
QLE8242-SR	FCoE	PCI Express	x4/x8 lane	3.3V	n/a
QLE2670/QLE2672	FC	PCI Express Gen2/Gen3	x8/x4 lane	n/a	n/a

Remember that some of the older adapters are tall (also referred to as full-height) and may not fit into a server with a low-profile chassis. These factors must be considered before implementing your configuration to avoid unnecessary delays and possible equipment swaps or returns.

Note: The QLogic QLE8042 FCoE CNA requires servers that can accommodate full-height, full-length PCI Express adapters. Always refer to the latest [EMC Support Matrix](#) for the most up-to-date information on servers that support these adapters.

Fibre Channel over Ethernet (FCoE)

EMC supports QLogic Fibre Channel over Ethernet (FCoE) Converged Network Adapter (CNA). FCoE adapters represent a method to converge both Fibre Channel and Ethernet traffic over a single physical link to a switch infrastructure that manages both storage (SAN) and network (IP) connectivity within a single unit.

The benefits of FCoE technology become apparent in large data centers:

- ◆ Where dense, rack-mounted and blade server chassis exist
- ◆ Where physical cable topology simplification is a priority
- ◆ In virtualization environments, where several physical storage and network links are commonly required

The installation of the QLogic FCoE CNA provides the host with an Intel-based 10 Gb Ethernet interface (using the existing in-box drivers), and a QLogic Fibre Channel adapter interface

Upon installation of the proper driver for the FCoE CNA, the Fibre Channel interface will function identically to that of a standard QLogic Fibre Channel HBA. The FCoE CNA simply encapsulates Fibre Channel traffic within Ethernet frames. As such, FC-based content within this guide also applies directly to QLogic FCoE CNAs.

In-depth information about FCoE and its supported features and topologies can be found in the "Fibre Channel over Ethernet (FCoE)" chapter of the *EMC Networked Storage Topology Guide*, available through E-Lab Interoperability Navigator at: <http://elabnavigator.EMC.com>.

For CNA configuration procedures, refer to "FCoE converged network adapter (CNA) procedures" on page 91.

Booting from the external storage array

If you are setting up your server to boot Windows from the external array, it is necessary to have the most recent BIOS installed on the adapter from which you plan to boot. BIOS is software that runs on the adapter. When configured, it presents a disk to the operating system from which to boot. During boot, the adapter driver is loaded and assumes control of the disk from the BIOS.

Note: If you are not planning to use the EMC array as a boot disk, these procedures can be skipped. Move on to the [“Installing the Windows operating system” on page 55](#).

First, install the BIOS to the adapter, and then configure it to boot from the EMC array.

Create a floppy disk with the EMC-approved driver and BIOS

For the QLogic CD-ROM packaged with your adapter, select the driver for your Windows operating system. Be sure to select the **Legacy Install Kit** as this will allow you to extract the necessary driver files. The Legacy Install Kit is a .zip archive file. Unzip the files contained in the .zip archive onto a blank floppy disk.

BIOS for your adapter will also be provided on the QLogic CD-ROM. Note that the versions on the CD-ROM should already be installed on the adapter. If you are upgrading your firmware and/or BIOS, use the files on the CD-ROM or download the latest versions from the QLogic website following the procedure described in [“Downloading latest QLogic drivers/firmware/BIOS files” on page 16](#). Unzip the .zip archive files onto your floppy disk and keep the diskette handy during the installation procedures.

Necessary files for BIOS upgrades are: `flasutil.exe`, two files (.dat and .def) containing EMC-Approved NVRAM settings, and the correct BIOS .bin file. Also included in the BIOS archive is a .bat file, which is used to flash the new BIOS to the adapter and to apply the EMC NVRAM settings to the adapter.

Note: NVRAM is short for Non-volatile RAM. This is a special portion of memory on the adapter where adapter settings are stored.

Note: Driver and BIOS files may not fit on the same floppy. If you run out of disk space, use a single floppy disk for the driver files, and another disk for the BIOS files.

Install/upgrade firmware and boot BIOS from DOS

To update using a DOS boot diskette:

1. Format a 3.5-inch diskette and extract the BIOS and NVRAM files from the archive file (.zip or self-extracting .exe) onto the diskette. Make sure `flasutil.exe` and the source files (BIN, DEF, DAT, and BAT files) are in the same directory. EMC-specific settings are contained in files named `emcXXXX.def` and `emcXXXX.dat` where `XXXX` is the model number of the adapter. These settings files (also referred to as NVRAM setting files) should also be in the same directory with the flash utility and source files. Note that some versions of BIOS may use different filenames depending on the version and adapter model.

Be sure to check the readme included with the BIOS files to make sure you have all of the appropriate files before proceeding to [Step 2](#).

2. Reboot your Windows host system using a DOS diskette.
3. At the `A:\>` prompt, insert the diskette that contains the QLogic BIOS files (created in step 1).
4. Run the included batch file at the command prompt. This is the file with the .BAT extension.

For example, QLA2340 adapters have a batch file called `2340flsh.bat` or QLE2462 adapters have a batch file called `eql2462.bat`. This batch file will automatically execute the necessary commands to flash the BIOS and NVRAM files to the board.

5. If you have other QLogic adapter models installed in the server, you may need to download additional BIOS packages and repeat [Step 1](#) through [Step 4](#) to update the BIOS' on those adapters.

With the latest BIOS installed, configure and verify the BIOS settings to use the EMC storage array as the boot disk. Ensure that only a single I/O path to the LUN exists when installing the OS. A single adapter should have access to only a single array port at this point.

QLogic Fibre Channel adapter BIOS/boot LUN settings

This section describes the steps required to configure a QLogic adapter boot BIOS for allowing an array-attached LUN to be used as a boot disk for the server.

This section assumes the following steps have been completed:

- ◆ The QLogic adapter's BIOS and NVRAM settings are updated to the latest version. Refer to [“Install/upgrade firmware and boot BIOS from DOS” on page 27](#) for details.
- ◆ In direct-attach configurations, an adapter has a physical connection to the array port.
- ◆ In fabric-attach configurations, an adapter has a physical connection to the switch/fabric, and has been zoned to the array, so a single adapter to be used for boot has one logical I/O path to the array. Refer to your switch documentation for details.

Before configuring adapter settings to boot from an array-based LUN, your server's settings should be adjusted to disable booting from an internal system drive. The procedure for disabling boot from an internal system drive is largely dependent upon the server platform.

- ◆ In some instances, internal boot can be disabled via entering the onboard SCSI/RAID controller's BIOS utility. For example, an Adaptec based controller can be configured by pressing CTRL-A, when the Adaptec banner is displayed during Power-On Self Test (POST).
- ◆ Some servers will require entering the system BIOS utility to either disable boot from an internal drive, or to change the controller boot order, so the boot adapter is enumerated before the internal disk controller, allowing the array-attached LUN to be the first disk visible to the server. Refer to your server documentation for details.

- ◆ In some server instances, boot from an internal drive cannot be explicitly disabled. In this case, the internal drive(s) must be physically disconnected or removed from the server. Refer to your server documentation for details.

IMPORTANT

In some cases, reinserting an internal drive (after having previously removed it and configured a adapter for boot) may result in the internal drive being re-enumerated as the first drive, and possibly modifying the boot order, such that the server will attempt to boot from the internal drive, rather than the intended array-based LUN. Ensure that appropriate precautions are taken to make sure the server will properly boot from an array-based LUN before reinserting an internal system drive.

Legacy (x86 and most EM64T-based servers) boot BIOS configuration

During POST, the QLogic banner will be displayed.

1. Press **Ctrl+Q** to enter the Configuration utility:

```
QLogic Corporation
QLA2300/2310 PCI Fibre Channel ROM BIOS Version 1.47
Copyright (C) QLogic Corporation 1993-2004. All rights reserved.
www.qlogic.com

Press <CTRL-Q> for Fast!UTIL

BIOS for Adapter 0 is disabled
ROM BIOS NOT INSTALLED

<Alt-Q> Detected, Initialization in progress, Please wait...
```

Figure 6 QLogic banner

2. Select the adapter (enumerated by its I/O address) to be used for boot.

If multiple adapters are installed, there will be multiple adapter entries. The order of the adapter instances listed is the order they will be scanned for a boot device; (note that this does not necessarily correspond to PCI slot numbering), and press **Enter**.

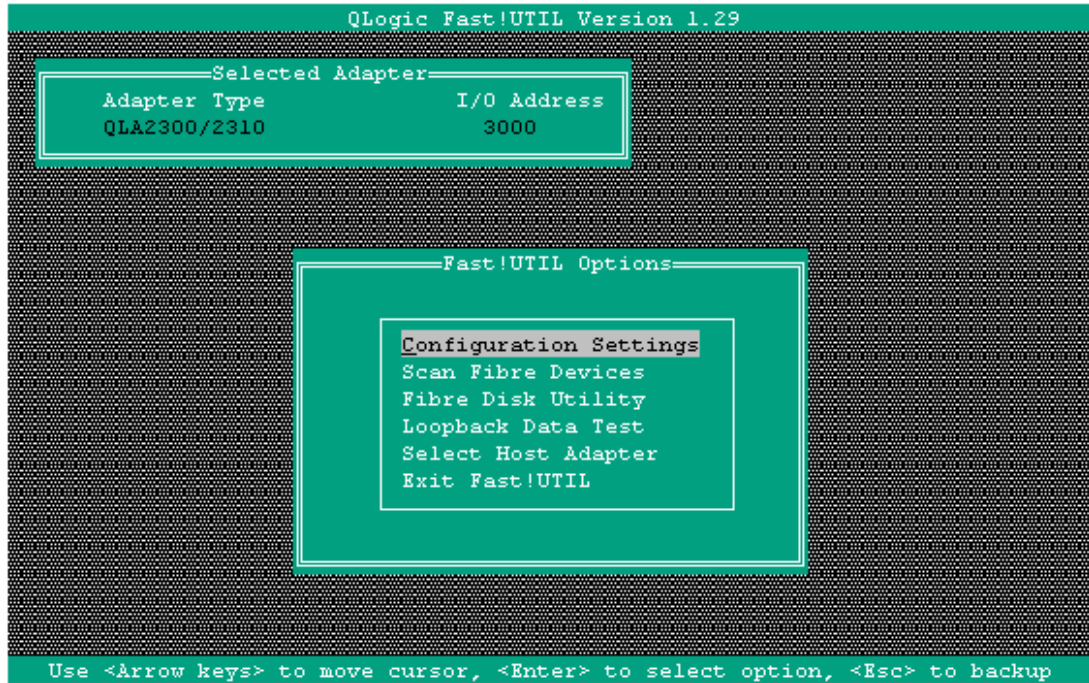

Figure 7 Main Fast!UTIL options window

3. Select **Configuration Settings** from the main **Fast!UTIL Options** dialog, and press **Enter**.

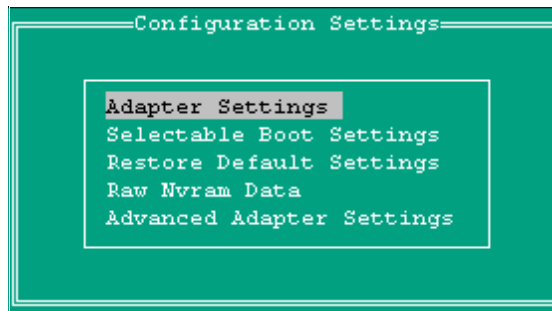

Figure 8 Configuration Settings window

4. Select **Adapter Settings** from the **Configuration Settings** window and press **Enter**.

```

Adapter Settings

BIOS Address:          CC000
BIOS Revision:        1.47
Adapter Serial Number: D35783
Interrupt Level:      15
Adapter Port Name:    210000E08B05A71F
Host Adapter BIOS:    Enabled
Frame Size:           2048
Loop Reset Delay:     5
Adapter Hard Loop ID: Disabled
Hard Loop ID:         0
Spinup Delay:         Disabled
Connection Options:   2
Fibre Channel Tape Support: Enabled
Data Rate:            2
  
```

Figure 9 Adapter Settings window

5. The **Host Adapter BIOS** setting is **Disabled** by default; select this setting and press **Enter** to enable **Host Adapter BIOS**.

Press **Esc** to return to the previous **Configuration Settings** (as shown in [Figure 8 on page 30](#)).

```

Configuration Settings

Adapter Settings
Selectable Boot Settings
Restore Default Settings
Raw Nvram Data
Advanced Adapter Settings
  
```

Figure 10 Configuration Settings window

- From the **Configuration Settings** dialog, select **Selectable Boot Settings** and press **Enter**.

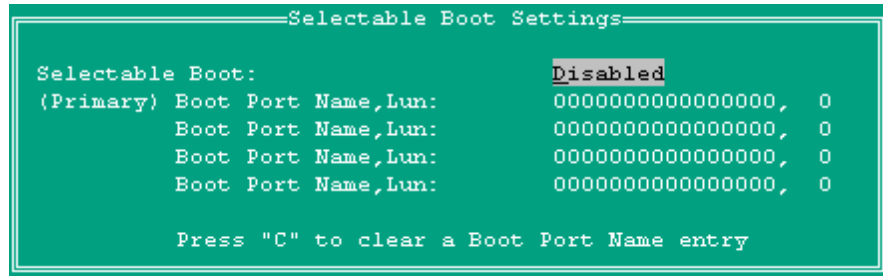

Figure 11 Selectable Boot Settings window

- Selectable Boot** is **Disabled** by default. Select this setting and press **Enter** to enable **Selectable Boot**.
- Scroll down to the **(Primary) Boot Port Name, LUN:** setting, and press **Enter**.

The **Fast!UTIL** will now scan for attached FC devices (as shown in [Figure 12 on page 33](#)). If physical connectivity to the array is setup properly via zoning, then the array port will be found after this scan. Use the <**PageUp**> and <**PageDown**> keys to navigate the list of target IDs for the array port being used for boot.

Select Fibre Channel Device					
ID	Vendor	Product	Rev	Port Name	Port ID
128	No device present				
129	EMC	SYMMETRIX	5670	5006048&CCC8321E	2C2B00
130	No device present				
131	No device present				
132	No device present				
133	No device present				
134	No device present				
135	No device present				
136	No device present				
137	No device present				
138	No device present				
139	No device present				
140	No device present				
141	No device present				
142	No device present				
143	No device present				

Use <PageUp/PageDown> keys to display more devices

Figure 12 Select Fibre Channel Device window

If no entries appear at any target IDs, verify the following:

- If multiple adapters are present, verify the adapter select in the BIOS Utility is the same that currently provides the I/O path to the storage (at this point, only one I/O path should be configured to the boot LUN).
 - For VNX series or CLARiiON systems, verify that the single I/O path points to the SP which owns the boot LUN.
 - For FC-SW environments, verify fabric zoning parameters, so a single I/O path exists to the boot LUN. Refer to array software documentation for details.
 - Check physical FC connectivity between the adapter and array (direct attach environment) or switch (FC-SW environment).
9. Select the array port to be used for boot, and press **Enter**.

If LUNs are allocated to the adapter (using LUN Masking schemes, such as Access Logix™ or Volume Logix), they will be presented at their LUN number.

For example, [Figure 13](#) shows that LUN 17 is masked to the adapter. The LUN is available and is presented as "Supported" by the BIOS.

```

-----Select LUN-----
Selected device supports multiple units
LUN      Status
-----
16      Not supported
17      Supported
18      Not supported
19      Not supported
20      Not supported
21      Not supported
22      Not supported
23      Not supported
24      Not supported
25      Not supported
26      Not supported
27      Not supported
28      Not supported
29      Not supported
30      Not supported
31      Not supported

Use <PageUp/PageDown> keys to display more devices

```

Figure 13 Example of LUN 17 allocated to adapter

If no numbered entries appear in the above figure, verify the following:

- For VNX series or CLARiiON systems, verify the single I/O path points to the SP that owns the boot LUN.
 - Verify array LUN masking settings are configured so this adapter has visibility to the appropriate LUN. Refer to array software documentation for details.
10. Select a supported LUN to use as the boot LUN (shown as LUN 17 in [Figure 13](#)) and press **Enter**.

The **Selectable Boot Settings** dialog is displayed ([Figure 14 on page 35](#)) with the updated array port and LUN number as the boot device.

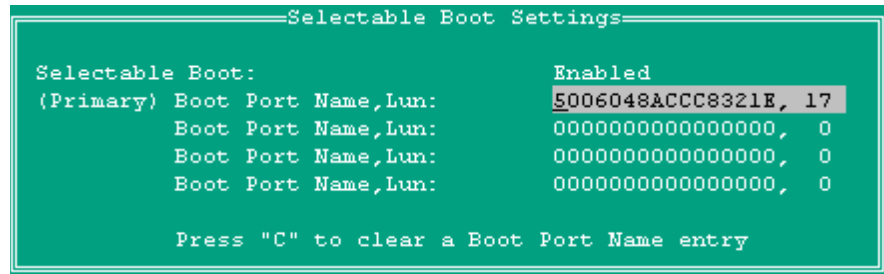

Figure 14 Selectable Boot Settings window

11. Press **Esc** to return to the previous **Configuration Settings** dialog.
12. Press **Esc** on the **Configuration Settings** dialog.

A dialog will appear to warn of a configuration change (as shown in [Figure 15](#)).

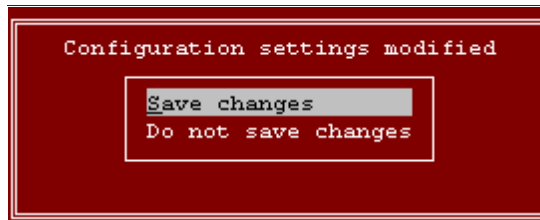

Figure 15 Warning dialog

13. If the settings are correct, select **Save changes** to return to the initial **Fast!UTIL Options** dialog.

Otherwise, press **Esc** to make additional changes, or select **Do not save changes** and press **Enter** to return to the initial **Fast!UTIL Options** window (as shown in [Figure 16 on page 36](#)).

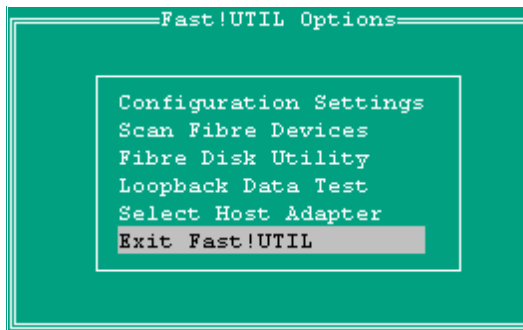

Figure 16 Fast!UTIL Options window

14. To exit the **Fast!UTIL** configuration utility, select **Exit Fast!UTIL** and press **Enter**.

The system will now reboot.

During the subsequent reboot, the QLogic BIOS banner screen should show the array and LUN specified as a boot-capable LUN (as shown in [Figure 17](#)).

```

QLogic Corporation
QLA2300/2310 PCI Fibre Channel ROM BIOS Version 1.47
Copyright (C) QLogic Corporation 1993-2004. All rights reserved.
www.qlogic.com

Press <CTRL-Q> for Fast!UTIL
ISP23xx Firmware Version 3.03.08
QLogic adapter using IRQ number 15

-----
Drive Letter C: is Moved to Drive Letter D:
LOOP ID 129,17 is Installed As Drive C:

-----
Device Device Adapter Port Lun Vendor Product Product
Number Type Number ID Number ID ID Revision
  80 Disk 0 2C2B00 17 EMC SYMMETRIX 5670
ROM BIOS Installed

```

Figure 17 Typical QLogic BIOS banner screen

At this point, the OS installation can begin using this LUN as the boot volume.

Pre-configured settings

The following parameters have been pre-configured in the EMC NVRAM settings file. They are also configurable in the Host Adapter Settings, Advanced Adapter Settings, and Extended Firmware Settings menus. These menus and selections, when viewed in SANSurfer v2.0.25 and later, may appear under different headings.

[Table 2](#) lists the pre-configured parameters for 1 and 2 Gb/s.

Table 2 Pre-configured parameters for 1 and 2 Gb/s

Parameter	QLogic default setting	EMC-approved setting
Data Rate	0 (1 Gb/s)	2 (Auto Select)
Execution Throttle	16	256
Connection options (topology)	2 (Loop preferred, otherwise point-to-point)	2 (Loop preferred, otherwise point-to-point)
Loop Reset Delay	5	5
Enable LIP Full Login	Yes	Yes
Enable Target Reset	No	Yes
Port Down Retry Count	30	45
Link Down Timeout	30	45
Luns Per Target	8	256
Adapter Hard Loop ID	Enabled	Disabled
Hard Loop ID	0	0
Descending Search LoopID	0	1
Operation Mode	0	0
Interrupt Delay Timer	0	0
Enable Interrupt (24xx adapters)	No	No

Table 3 lists the pre-configured parameters for 4 Gb/s.

Table 3 Pre-configured parameters for 4 Gb/s

Parameter	EMC-approved setting for 4 Gb/s
Data Rate	Auto
Execution Throttle	256
Connection options	Loop preferred, otherwise point-to-point
Loop Reset Delay	5
Enable LIP Full Login	Yes
Enable Target Reset	Yes
Port Down Retry Count	45
Link Down Timeout	45
LUNs Per Target	256
Enable Hard Loop	No
Hard Loop ID	0
Operation Mode	0
Interrupt Delay Timer	0
Frame Size	2048
Enable BIOS	No
Enable FC Tape	Yes
Login Retry Count	8
Enable Receive OoOFrame	Yes

Table 4 lists the pre-configured parameters for 8 Gb/s and 16 Gb/s.

Table 4 Pre-configured parameters for 8 Gb/s and 16 Gb/s

Parameter	EMC-approved setting	EMC-approved setting
	8 Gb/s	16 Gb/s
Data Rate	Auto	Auto
Execution Throttle	65535	65535
Connection options	Loop preferred, otherwise point-to-point	Loop preferred, otherwise point-to-point
Loop Reset Delay	5	5
Enable LIP Full Login	Yes	Yes
Enable Target Reset	Yes	Yes
Port Down Retry Count	45	30
Link Down Timeout	45	30
LUNs Per Target	256	128 ^a
Enable Hard Loop	No	No
Hard Loop ID	0	0
Operation Mode	0	0
Interrupt Delay Timer	0	0
Frame Size	2048	2048
Enable BIOS	No	No
Enable FC Tape	Yes	Yes
Login Retry Count	8	8
Enable Receive OoOFrame	Yes	Yes

a. This is a legacy setting for older storage arrays not supporting the Report LUNs command.

EFI (IA64 Itanium and some x64 servers) system firmware configuration

1. Prior to booting the server, ensure that media (USB memory drive, CD-ROM, or floppy) which contains the QLogic EFI boot code/utility is physically present in the system.
2. Following POST of the server, the **Firmware Boot Manager** (similar to [Figure 18](#)) menu will be displayed.

Using the arrow keys, select the option for **EFI Shell** and press **Enter**.

```
Firmware Boot Manager
Boot options: Enter number or ↑/↓ to select, 'Enter' to execute

1 EFI Shell [Built-in]
2 Acpi(PNP0A03,0)/Pci(5|1)/Ata(Primary,Master)
3 Acpi(PNP0A03,1)/Pci(4|0)/Mac(0002551F80E0)
4 Acpi(PNP0A03,1)/Pci(4|1)/Mac(0002559F80E0)
5 CDROM
6 Acpi(PNP0A03,0)/Pci(5|1)/Ata(Primary,Master)

System options: Enter letter or ↑/↓ to select, 'Enter' to execute

Boot Option Maintenance      Diagnostics      EFI Shell
Configuration/Setup          Driver Setup      Flash
```

Figure 18 Firmware boot manager menu

- The EFI shell will open, and the Device Mapping Table may be listed by default (similar to [Figure 19](#)). If the Device Mapping Table is not listed, type **map** and press **Enter**.

```

Device Mapping Table
fs0 : MemMap(15:FF000000-FFFFFFFF)
fs1 : MemMap(8:FF800200-FFBFFFFFF)
fs2 : MemMap(16:1B846000-1B9ADFFF)
fs3 : Acpi(PNP0A03,0)/Pci(5|1)/Ata(Primary,Master)/CDROM(Entry0)
fs4 : Acpi(PNP0A03,0)/Pci(5|1)/Ata(Primary,Master)/CDROM(Entry1)
fs5 : Acpi(PNP0A03,0)/Pci(5|3)/Usb(0,0)/HD(Part1,Sig19EEC514)
fs6 : Acpi(PNP0A03,1)/Pci(3|0)/Scsi(Pun0,Lun0)/HD(Part1,SigFA5B03C0-EA5E-01C3
-507B-9E5F8078F531)
blk0 : MemMap(15:FF000000-FFFFFFFF)
blk1 : MemMap(8:FF800200-FFBFFFFFF)
blk2 : MemMap(16:1B846000-1B9ADFFF)
blk3 : Acpi(PNP0A03,0)/Pci(5|1)/Ata(Primary,Master)
blk4 : Acpi(PNP0A03,0)/Pci(5|1)/Ata(Primary,Master)/CDROM(Entry0)
blk5 : Acpi(PNP0A03,0)/Pci(5|1)/Ata(Primary,Master)/CDROM(Entry1)
blk6 : Acpi(PNP0A03,0)/Pci(5|3)/Usb(0,0)
blk7 : Acpi(PNP0A03,0)/Pci(5|3)/Usb(0,0)/HD(Part1,Sig19EEC514)
blk8 : Acpi(PNP0A03,1)/Pci(3|0)/Scsi(Pun0,Lun0)
blk9 : Acpi(PNP0A03,1)/Pci(3|0)/Scsi(Pun0,Lun0)/HD(Part1,SigFA5B03C0-EA5E-01C3
-507B-9E5F8078F531)
blkA : Acpi(PNP0A03,1)/Pci(3|0)/Scsi(Pun0,Lun0)/HD(Part2,SigFA9CA0A0-EA5E-01C3
-F1B3-12714F758821)
blkB : Acpi(PNP0A03,1)/Pci(3|0)/Scsi(Pun0,Lun0)/HD(Part3,Sig5CE668E0-7CC6-01C5
-A1F4-04622FD5EC6D)
fs5:\>

```

Figure 19 Device mapping table

- The file systems available to the server are listed in the Device Mapping Table, referenced by **fsN**, where *N* is a different number for each available file system. The description next to the **fsN** entry references the type of media on which the file system resides.

In the example shown in [Figure 19](#):

- **fs0**, **fs1** and **fs2** refer to memory ramdisks
- **fs3** and **fs4** refer to file systems on a CD inserted in the CD-ROM
- **fs5** refers to a file system on aUSB memory drive
- **fs6** refers to an existing file system on an internal hard drive.

- The file system you select depends upon what media contains the QLogic EFI boot code/utility. In this example, the QLogic EFI boot code/utility resides on the USB memory drive.
3. Point the EFI shell to the proper file system by typing **fsN:** (where *N* is the number which references the proper file system) followed by **Enter**.
 4. Before loading the QLogic EFI boot code/driver to the adapter(s), ensure that any old EFI boot code loaded in the system has been removed. Type **drivers** at the EFI shell prompt and press **Enter**.
 - a. Look for any driver listings that reference "QLogic Fibre Channel Adapter," similar to the listing shown in [Figure 20](#)

```
60 00000140 D X X 1 - QLogic Fibre Channel Driver          PciRom Seg=00000000
```

Figure 20 Reference to QLogic Fibre Channel driver

- b. If such a driver entry exists in the output, it should be removed before installing the current driver. Make note of the first two digits on the line which references the QLogic Fibre Channel Driver ("60" in the example shown in [Figure 20](#)); this is the "driver handle". Type **unload <driver handle>**.

For the example shown in [Figure 20](#), **unload 60** would be used to remove the EFI driver. The system will prompt to "Unload Protocol Image (y/n)?". Type **y** and press **Enter**. The existing QLogic EFI driver will now be removed.
5. Type **dir** and press **Enter** to list the contents of the directory. If the directory contents are not consistent with what you expect, and do not appear to contain the QLogic boot code/utility, the file system select may be incorrect.
6. Verify the proper file system has been selected. If the QLogic boot code/utility resides in a subdirectory, type **cd subdirectory** and press **Enter**.

```

fs0:\qlogic> dir
Directory of: fs0:\qlogic

12/01/05  11:29a <DIR>          2,048 .
12/01/05  11:29a <DIR>           0 ..
08/10/04  01:11p                136,704 efiiaux.drv
08/10/04  09:44a                272,415 EfiCfg.pdf
07/24/04  05:13p                295,936 efiutil.efi
04/29/04  02:03p                259,600 EfiUtil.pdf
08/18/04  03:41p                12,287 nvram23.dat
08/10/04  01:13p                55,296 ql2312ef.bin
08/10/04  01:13p                72,192 ql2312fw.bin
08/18/04  03:49p                12,842 qlfireadme.txt
08/18/04  04:25p                 2,615 ReleaseNotes.txt
          9 File(s)    1,119,887 bytes
          2 Dir(s)
fs0:\qlogic>

```

Figure 21 QLogic directory

- The directory listing should contain the QLogic EFI boot code/utility downloaded to the media (as shown in [Figure 21](#)).
- The files of importance will take the following form:

EFIutil.efi	QLogic EFI utility for updating adapter driver/firmware.
qlxxxxx.drv	EFI driver for QLogic (used by EFIutil when the driver has not been flashed to the adapter.)
qlxxxxxxxxx.bin	EFI boot driver image file package. Flashed to the adapter to cause the EFI boot driver to load automatically during system start-up.

7. Type **efiutil** and press **Enter**.

```

Fibre Channel Card Efi Utility 1.32 (7/19/2004)
QLogic Fibre Channel Adapter (driver 1.42, firmware 0.00.000) AUX
QLogic Fibre Channel Adapter (driver 1.42, firmware 0.00.000) AUX

2 Fibre Channel Adapters found:

Adapter      Path                               WWN              Driver (Firmware)
A0 Acpi(PNP0A03,4)/Pci(3|0)          210000E08B0955A7 1.42 (0.00.000)
A1 Acpi(PNP0A03,4)/Pci(3|1)          210100E08B2955A7 1.42 (0.00.000)

efiutil>

```

Figure 22 Fibre Channel Card Efi utility

The QLogic adapter(s) installed in the server will be listed (as shown in [Figure 22](#)). Note the "firmware" version listed in the utility. If the firmware is listed as a specific version (not a series of zeroes), and "AUX" is not listed next to the firmware field at the top of the report then the EFI driver and firmware have been loaded on the adapter(s); proceed to the section immediately following [Figure 25 on page 47](#).

If the firmware is listed as a series of zeros, and "AUX" is listed next to the firmware field at the top of the report (as shown in [Figure 22](#)), this indicates the EFI boot code has not yet been installed on the adapter(s). Proceed as follows:

To install the EFI boot code driver and non-volatile RAM settings on the adapter(s):

The EFI boot code driver must be loaded onto the adapter(s) in order to be used by the EFI BIOS.

1. Type **update.nsh <qxxxxxx.bin>**, inserting the name of the EFI boot driver package (bin file). The update procedure with run and appear similar to the output shown in [Figure 22](#).
2. Press **Enter**.

```

fs0:\qllogic> efiutil all ew=q12312ef.bin

Fibre Channel Card Efi Utility 1.32 (7/19/2004)
QLogic Fibre Channel Adapter (driver 1.40, firmware 0.00.000) AUX
QLogic Fibre Channel Adapter (driver 1.40, firmware 0.00.000) AUX

2 Fibre Channel Adapters found:

Adapter      Path                               MWN          Driver (Firmware)
A0 Acpi(PNP0A03,4)/Pci(3|0) 210000E08B0955A7 1.40 (0.00.000)
A1 Acpi(PNP0A03,4)/Pci(3|1) 210100E08B2955A7 1.40 (0.00.000)

A0 Acpi(PNP0A03,4)/Pci(3|0) 210000E08B0955A7 1.40 (0.00.000)
Writing efi driver image to flash from file q12312ef.bin...
Old revision 1.40, New revision 1.40
File size 0000D800
WARNING: do NOT interrupt this operation...
Flash part Am29LV010
Writing new image...
.....
.....
Reinitializing adapter A0...
Image write complete.

A1 Acpi(PNP0A03,4)/Pci(3|1) 210100E08B2955A7 1.40 (0.00.000)
Writing efi driver image to flash from file q12312ef.bin...
Old revision 1.40, New revision 1.40
File size 0000D800
WARNING: do NOT interrupt this operation...
Flash part Am29LV010
Writing new image...
.....
.....
Reinitializing adapter A1...
Image write complete.

fs0:\qllogic>

```

Figure 23 QLogic efiutil all upgrade

- The utility will upgrade EFI boot code drivers on all adapters installed in the server and return to the EFI shell when complete (as shown in [Figure 23](#)). If any errors are reported during this process, verify that the correct EFI boot code driver for your adapter has been copied to your installation media.

- The appropriate NVRAM settings must now be loaded onto the adapter(s). Type **efiutil all nr=nvram23.dat** (`nvram23.dat` is the default NVRAM data file for QLA23xx-based adapters). Press **Enter**.

```
fs0:\qllogic> efiutil all nr=nvram23.dat
Fibre Channel Card Efi Utility  1.32  (7/19/2004)

2 Fibre Channel Adapters found:

Adapter      Path                               WWN          Driver (Firmware)
A0  Acpi(PNP0A03,4)/Pci(3|0)         210000E08B0955A7  1.40 (3.03.001)
A1  Acpi(PNP0A03,4)/Pci(3|1)         210100E08B2955A7  1.40 (3.03.001)

A0  Acpi(PNP0A03,4)/Pci(3|0)         210000E08B0955A7  1.40 (3.03.001)
Writing nvram from file nvram23.dat...
.....
Done.

A1  Acpi(PNP0A03,4)/Pci(3|1)         210100E08B2955A7  1.40 (3.03.001)
Writing nvram from file nvram23.dat...
.....
Done.

fs0:\qllogic>
```

Figure 24 Data loaded onto adapter(s) installed in server

- The NVRAM data will be loaded onto the adapter(s) installed in the server (as shown in [Figure 24](#)), and return to the EFI shell when complete.
 - If any errors are reported during this process, verify that the correct NVRAM data file (`nvram23.dat`) for your adapter has copied to your installation media.
- Type **reset** at the EFI shell prompt to reboot the server, allowing the updated drivers, firmware, and NVRAM settings to take effect.
 - Following the reboot, type **fsN:** (where N is the number which references the proper file system, as described earlier).
 - Press **Enter** to access the file system containing the QLogic EFI boot code.
 - If the EFI boot code resides in a subdirectory, type **cd <subdirectory name>** and press **Enter**.
 - Type **efiutil** to start the QLogic EFI Utility and press **Enter**.

- At this point, the QLogic adapter instances should be shown with a specific firmware version, and "AUX" should not be listed next to the firmware, as shown in [Figure 25](#).
- At this point, the EFI drivers, firmware, and NVRAM settings have loaded to the adapter(s).

```
fs0:\qllogic> efiutil

Fibre Channel Card Efi Utility  1.32  (7/19/2004)

2 Fibre Channel Adapters found:

Adapter      Path                               WWN              Driver (Firmware)
A0  Acpi(PNP0A03,4)/Pci(3|0)  210000E08B0955A7  1.40 (3.03.001)
A1  Acpi(PNP0A03,4)/Pci(3|1)  210100E08B2955A7  1.40 (3.03.001)

efiutil> |
```

Figure 25 QLogic adapter instances with specific firmware version

- Type **q** and press **Enter** to exit the QLogic EFI Utility.
- At the EFI shell prompt, type **drivers** and press **Enter**. Note the entries that reference "QLogic Fibre Channel Adapter" are similar to the listing shown in [Figure 26](#).

```
5F 00000140 D X X 1 - QLogic Fibre Channel Driver      PciRom Seg=00000000
60 00000140 D X X 1 - QLogic Fibre Channel Driver      PciRom Seg=00000000
```

Figure 26 QLogic Fibre Channel drivers

- Make note of the first two digits (referred to as the "driver handle") on the line that references the "QLogic Fibre Channel Driver". If multiple adapters are installed in the server, there will be multiple entries, as shown in [Figure 26](#).

The order of the adapter instances listed is the order in which they have been enumerated by the system. This does not necessarily correspond to PCI slot numbering. In this example, the two QLogic adapters installed in the server are using driver handles 5F and 60, respectively.

- Type **drvcfg**.
- Press **Enter**.

```
fs0:\qllogic> drvcfg
Configurable Components
Drv[33] Ctrl[46] Lang[eng]
Drv[3F] Ctrl[53] Lang[eng]
Drv[3F] Ctrl[54] Lang[eng]
Drv[4F] Ctrl[51] Lang[eng]
Drv[4F] Ctrl[52] Lang[eng]
Drv[5F] Ctrl[62] Lang[eng]
Drv[60] Ctrl[63] Lang[eng]
fs0:\qllogic>
```

Figure 27 Driver handle numbers

11. Find the driver handle numbers that correspond to those listed for the QLogic adapters (as shown in [Figure 27](#)). Note the two digits (preceded by **Ctrl**, as shown in [Figure 27](#)) next to the driver handles for the QLogic adapters. These are control handles.
12. Determine the adapter instance that will be used for boot, and enter the **QLogic Fibre Channel Driver Configuration Utility** by typing `drvcfg -s <driver handle> <control handle>` (where driver handle and control handle are the values that correspond to the adapter instance to be used for boot. In this example, "drvcfg -s 5f 62" is used.)
13. Press **Enter**.

The **Fibre Channel Driver Configuration Utility** menu will be displayed (as shown in [Figure 28 on page 49](#)).

```
Fibre Channel Driver Configuration Utility

NOTE: Do not redirect console output to a file.

Main Menu

NVRAM Parameters
 1. Edit Adapter Settings
 2. Edit Advanced Settings
 3. Edit Database
 4. Edit Boot Settings
Information
 5. Show Database
 6. Show Translation
 7. Show NVRAM Buffer
 8. Info
 9. Help
Operation
10. Abandon
11. Write
12. Quit

Enter a Selection: |
```

Figure 28 Fibre Channel driver configuration utility

14. Type **1** (**Edit Adapter Settings**) and **press Enter**.

```
Edit Adapter Settings

 0. Previous Menu
 1. Enable Hard Loop Id [n]
 2. Hard Loop Id (hex) [0]
 3. Reset Delay (dec) [5]
 4. Enable FC Tape [y]
 5. Frame Size [2048]
 6. Connection Option [Loop Preferred, Otherwise Point To Point]
 7. Data Rate [Auto]

Enter a Selection: |
```

Figure 29 Edit adapter settings

- By default, option 1 (**Enable Hard Loop ID**) is disabled.
 - In FC-SW environments, the default of disabled is the proper setting.

Select **2. Auto Topology: Pt to Pt first**.

Press **Enter** when your choice has been selected. The **Topology** information toward the top of the screen will reflect your selection.

Press **<Escape>** to return to the previous configuration window.

- In FC-AL/"direct attach" environments, Hard Loop ID should be enabled.

Type **1** and press **Enter**. The utility will prompt to **Enable Hard Loop Id [n]?**

Type **y** and press **Enter**. **Enable Hard Loop Id** will now be shown as **[y] (enabled)**.

Type **0** and press **Enter** to return to the previous menu as shown in [Figure 28 on page 49](#).

```

Connection Option:
 1. Loop Only
 2. Point To Point
 3. Loop Preferred, Otherwise Point To Point
Enter a Selection [3]:

```

Figure 30 Connection option

- By default, option 6 (Connection option) setting of **Loop Preferred, Otherwise Point To Point**, is acceptable for most configurations, and will auto-detect the connection topology.
 - To manually set the connection topology, type **6** and press **Enter**. Otherwise, type **0** and press **Enter** to return to the previous menu as shown in [Figure 28 on page 49](#).
 - In FC-SW environments, **Point To Point** is the appropriate setting. In FC-AL/"direct attach" environments, **Loop Only** should be selected.

Type the appropriate selection and press **Enter**. The selected connection topology will now be reflected.

Type **0**.

Press **Enter** to return to the previous menu as shown in [Figure 28 on page 49](#).

- Option 3 (Edit Database) allows the appropriate WWN of the array port, and the LUN address, to be specified for boot.

```
Enter a Selection: 3
Entry in WWN database to edit [0-4]? 0
Entry 0 Port WWN [0000000000000000]? 5006048ACD20165E
Node WWN [0000000000000000]? 5006048ACD20165E
Lun (hex) [00]? 1A
Entry in WWN database to edit [0-4]?
```

Figure 31 Example array port WWN and LUN values

Type **3** and press **Enter**.

Select **0** to select the first WWN database entry.

Press **Enter**.

The utility prompts for **Entry 0 Port WWN**.

15. Type the full WWN of the array port being used for boot and press **Enter**.

The utility prompts for **Node WWN**.

16. Enter the same WWN used above and press **Enter**.

The utility prompts for the hexadecimal LUN address to be used for boot;

17. Type the appropriate hexadecimal LUN value to be used for boot and press **Enter**. [Figure 31](#) shows example array-port WWN and LUN values.

Note: This utility does not explicitly check the values entered for validity, care must be taken to ensure that the proper array port WWN and LUN addresses have been entered.

The utility will prompt for another WWN database entry to modify,

18. Press **Enter** to return to the menu as shown in [Figure 28 on page 49](#).
19. Save the configuration changes by typing **11** (Write) and press **Enter**.

The utility reports that it is done saving changes

20. Press any key to continue, and then **12** to exit the utility.

The system reports that options have been set, as shown in [Figure 32](#).

```
Drv[5F] Ctrl[62] Lang[eng] - Options set. Action Required is Press [ENTER]
to continue
```

Figure 32 Options set

21. Press **Enter** to return to the EFI shell. Type **reset** to reboot the server to enable the changes.

22. Following the reboot, open the EFI shell. The **Device Mapping Table** may be listed by default (similar to [Figure 19 on page 41](#)).

a. If the **Device Mapping Table** is not listed, type **map** and press **Enter**.

```
blkB : Acpi(PNP0A03,1)/Pci(3|0)/Scsi(Pun0,Lun0)/HD(Part3,Sig5CE668EU-7CC6-01C5
-A1F4-04622FD5EC6D)
blkC : Acpi(PNP0A03,4)/Pci(3|0)/Fibre(WWN5006048ACD20165E,Lun0)
blkD : Acpi(PNP0A03,4)/Pci(3|0)/Fibre(WWN5006048ACD20165E,Lun1A000000000000)
Shell>
```

Figure 33 Example blkD as array port

b. Note any entries starting with **blk** (block-level devices, such as volumes) which reference a Fibre interface (as shown in [Figure 33](#)). The entry should list the array port WWN and LUN address specified in the configuration utility. [Figure 33](#) shows entry **blkD** as the array-port WWN and LUN specified during configuration. This is the EFI entry that specifies the specific array LUN to use for boot.

Note: The example shown in [Figure 33](#) also shows **BlkC** as **Lun0**. This is a Symmetrix®-based, read-only Volume Logix Database device used for LUN masking and cannot be used for boot, even though it is still detected by the QLogic EFI driver and is reported as visible.

At this point, the OS installation can begin using this LUN as the boot volume.

Verifying array/LUN visibility for boot

Verification of the adapter ability to access the boot LUN, and boot BIOS settings is recommended before installing the OS. Care must be taken to ensure that only a single I/O path to the LUN exists when installing the OS, a single adapter should have access to only a single array port at this point. Selecting BIOS and Boot LUN configuration settings vary with adapter vendor.

Refer to your array documentation for details on verifying adapter connectivity.

Installing a RAMDISK under the EFI shell

Intel provides an EFI toolkit on the Intel website <http://www.intel.com/technology/efi>. Included in the EFI toolkit is the RAMDISK driver. To install the RAMDISK driver on your system, copy the RAMDISK.EFI file to your USB flash drive.

Insert the USB flash drive in your EFI-based server's USB port and boot the server to the EFI shell. At the shell prompt, locate your USB flash drive in the device mapping table. A line similar to the following should be listed in the mapping table:

```
Fs0: Acpi (PNPOA03,0)/Pci (1D|1)Usb(1,0)/HD(Part1,Sig0D0C0B0A)
```

Switch to the USB flash drive by typing in the corresponding FS number, followed by a colon (i.e., Fs0:) and press **Enter**.

At the FS prompt, type **Load RAMDISK.EFI** and press **Enter**. You should see the message noting that the driver has loaded successfully.

To locate the new RAMDISK, type **Exit** and press **Enter**. From the system Boot Manager menu, select **EFI Shell** to go back to the EFI Shell. The device map should now show a new FS device as well as the previous USB device.

Note: The order of the devices may have shifted with the discovery of the RAMDISK.

```
Fs0: VenMsg(06ED4DD0-FF78-11D3-BDC4-00A0C94053D1)
Fs1: Acpi (PNPOA03,0)/Pci (1D|1)/Usb(1,0)/HD(Part1,Sig0D0C0B0A)
```

In the above example, the RAMDISK is now Fs0. Now you can copy your driver files for your adapter to the RAMDISK. Switch to your USB flash drive with the driver files and copy the files to the

RAMDISK by using the **copy** command. As with DOS, the copy command can use an asterisk to grab multiple files, (i.e., `COPY *.* fs0:`).

Once the files are copied to the RAMDISK, you may proceed to install Windows.

Note: If the server is rebooted at any time, this procedure will need to be repeated as the RAMDISK is deleted during a reboot.

Installing the Windows operating system

This section provides procedures for installing Windows 2000/2003 and Windows 2008 operating systems.

- ◆ [“Windows 2000/2003 internal or external boot disk installation,”](#) next
- ◆ [“Windows 2008 internal or external boot disk installation”](#) on page 63

Windows 2000/2003 internal or external boot disk installation

This section is a step-by-step procedure for installing Windows 2000/2003 Operating System to either an internal or external boot device.

After you have your adapter(s) installed in your server, and configured for external boot if necessary, the next step is to install the Windows operating system. If you intend to boot to an external device please refer to [“Booting from the external storage array”](#) on page 26 for setting the boot BIOS for external boot and selecting the external boot lun. If your system is EFI-based refer to [“Installing a RAMDISK under the EFI shell”](#) on page 53. Also refer to your server’s documentation for preparing your server for external boot.

QLogic provides a minimal driver installation kit for boot from SAN installations. This kit includes an adapter driver that is small enough to fit on a floppy disk. Be sure to download the correct kit in order to install Windows on your external boot LUN.

Note: If you intend to boot to an external disk, only present the LUN that you intend to boot from. All additional luns can be added after the installation. This will eliminate any confusion on selecting the correct partition for installation and eliminates any problems that the Operating System could encounter on reboot during the installation. Also confirm there is only **one** path to the storage array. Having more than one path can cause the operating system to fail during the installation.

You need the following materials to install Windows:

- ◆ A Windows CD-ROM for the Windows version you wish to install
- ◆ AN EMC-approved boot driver on diskette, or an EFI RAMDisk if it is an EFI based install

Note: Driver version 9.1.7.16 and later requires a minimum of Windows 2003 with Service Pack 2 and STORPort hotfix Q950903. Since these required patches/QFEs do not come pre-installed on the Windows 2003 installation CD-ROM, you must install Windows 2003 using an installation CD with Service Pack 2 included in the installation kit. If you do not have an installation CD that includes Service Pack 2, install the Windows OS using QLogic driver v9.1.4.15 and then upgrade to v9.1.7.16 or later after installing the correct Service Pack and QFE.

To install Windows:

1. Insert a bootable Windows CD-ROM in the drive and reboot the system. If your system has a bootable disk already configured from a previous installation, the software will prompt you to press any key to boot from CD-ROM.

If you are booting from your server's internal hard disk, you may skip to [Step 6](#) on [page 60](#) when the **Windows Setup** screen displays.

2. If you are installing Windows to boot from an external array disk, you will need to supply setup with the adapter driver. To do this, immediately after the Windows installation begins, press **F6** when directed or when the blue screen appears. Otherwise, proceed to step 6.

Pressing **F6** tells the Windows installer you want to load a third-party driver before proceeding with the installation.

If you do not press **F6** in time to add the drivers, restart the server and try again. You will know if you missed the **F6** function to install third-party drivers when the setup returns with a warning that it cannot find a partition to load the operating system

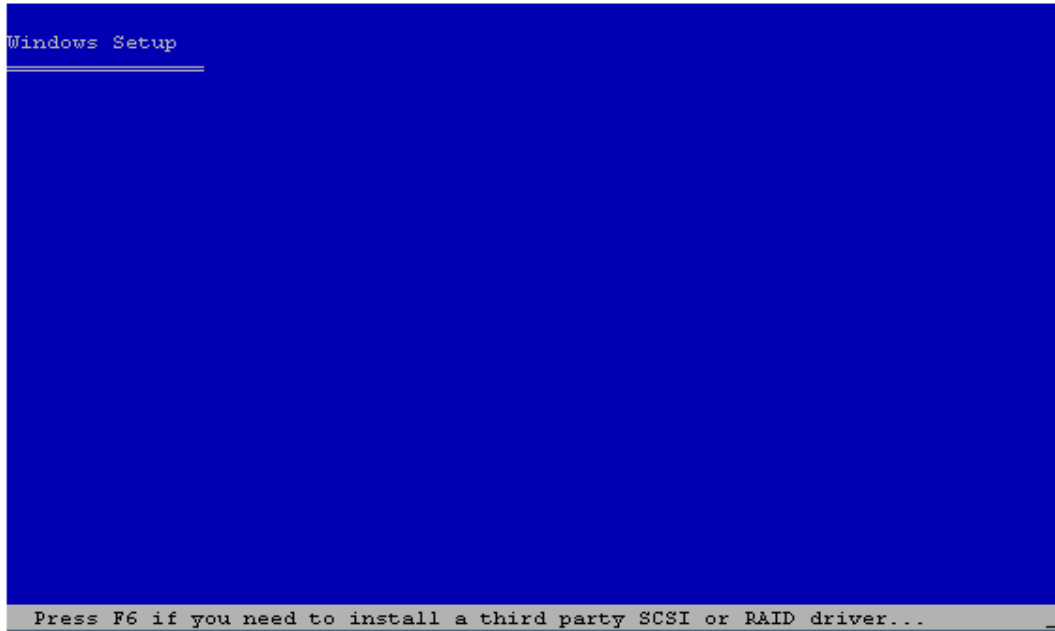

Figure 34 Windows Setup screen with F6 prompt

Note: Windows 2000 does not display the F6 prompt.

3. When prompted for additional drivers, select **S (Specify Additional Device)**.

```
Windows Setup
=====

Setup could not determine the type of one or more mass storage devices
installed in your system, or you have chosen to manually specify an adapter.
Currently, Setup will load support for the following mass storage device(s):

<none>

* To specify additional SCSI adapters, CD-ROM drives, or special
  disk controllers for use with Windows, including those for
  which you have a device support disk from a mass storage device
  manufacturer, press S.

* If you do not have any device support disks from a mass storage
  device manufacturer, or do not want to specify additional
  mass storage devices for use with Windows, press ENTER.
```

Figure 35 Specifying a driver for your adapter

4. Insert the EMC-approved adapter Drivers diskette or EFI RAMDisk if applicable for your OS. Then press **Enter** to continue. This displays a screen similar to [Figure 36 on page 59](#).

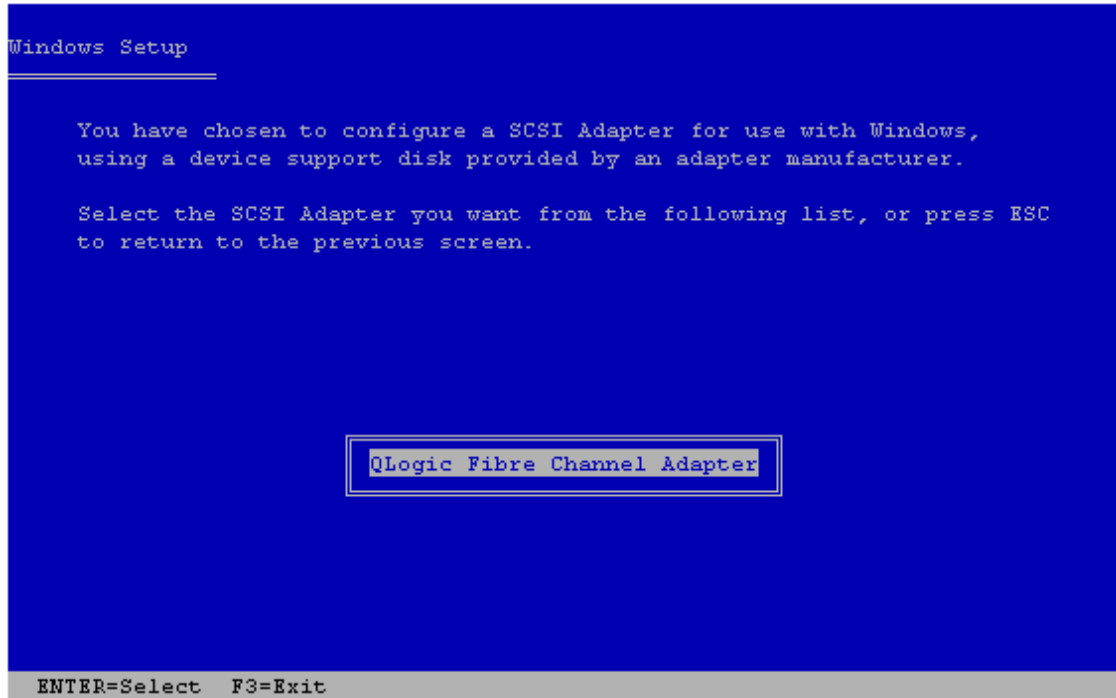

Figure 36 Adapter selection screen

5. Select the appropriate boot adapter and press **Enter**. (You may have to scroll down to find the appropriate driver.)

Note: Depending on the version of Windows, you may receive an error message that the default driver is newer than the provided one. Ignore this message.

Setup continues to load files, and a **Windows Setup** screen appears.

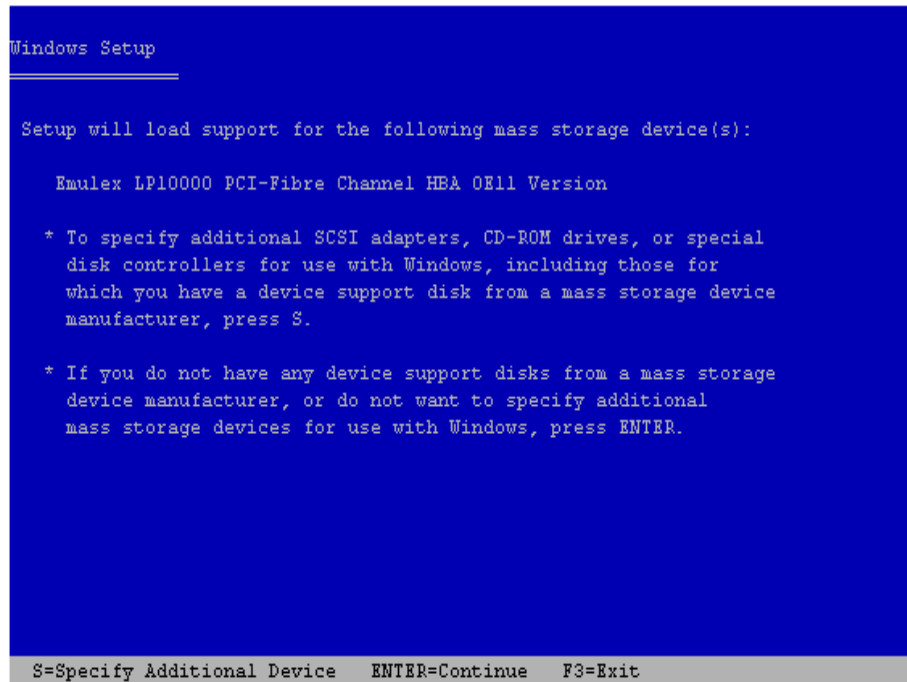

Figure 37 Windows setup screen

6. Press **Enter** to begin the setup procedure.

Note: If you are installing Windows on a newly created LUN, you may receive a message that your boot disk is new or erased. Press **C** to continue.

A Windows Licensing Agreement appears.

7. Read the license agreement. (Press **Pg Dn** as necessary to scroll through the text.) To accept the agreement, press **F8**.

Setup inspects your computer's hardware configuration. The setup screen displays disk partition information (if your system already contains partitions), or lets you create a new partition. (Refer to [Figure 38 on page 61.](#))

Note: The Windows 2000 boot LUN cannot exceed 7.8 GB unless INT-13 extensions are enabled in the adapter BIOS. (Refer to Microsoft Knowledge Base article Q240672.)

Windows Server 2003, Enterprise Edition Setup

The following list shows the existing partitions and unpartitioned space on this computer.

Use the UP and DOWN ARROW keys to select an item in the list.

- * To set up Windows on the selected item, press ENTER.
- * To create a partition in the unpartitioned space, press C.
- * To delete the selected partition, press D.

34728 MB Disk 0 at Id 0 on bus 4 on cpqccissm [MBR]

Unpartitioned space	34724 MB (32611 MB free)
---------------------	---------------------------

ENTER=Install C=Create Partition F3=Quit

Figure 38 Existing partitions

8. If you are installing an operating system for the first time, highlight **Unpartitioned Space** on the adapter. Then:
 - Press **Enter** to use the entire disk as one partition
or
 - Press **C** to create a custom partition, and then specify the partition size

If the new disk is displayed as **Unformatted** or **Damaged** you must delete the partition before continuing. To do this, press **D**, and follow the onscreen delete instructions. After you delete the partition, the disk will then appear as **Unpartitioned Space**.

If you are reinstalling Windows, the setup software prompts you to overwrite or upgrade:

- To overwrite, press **Esc** and follow instructions.
 - To upgrade, press **Enter**.
 - To create a new hard-disk partition, you must first delete the existing partition, and then create a new one. To do so, select the partition you want to delete, press **D**, and then follow the onscreen instructions to complete the deletion of the partition. (Once the system deletes the partition, you can press **C** to create a new one.)
9. The setup software prompts you to specify the file system format for the partition. Select **NTFS file system** format (which is suitable for most sites) and press **Enter**, unless you have other specific requirements.

Note: For background information on the choice of the NTFS file system, refer to Microsoft Knowledge Base Article 184006.

Setup formats the partition, copies the Windows system files to the partition, and starts rebooting the server.

10. When prompted, remove the diskette and CD-ROM.
11. If your system prompts you to press any key to boot from CD-ROM, do not press a key. Instead, allow the system to boot from the array (if external) or the local disk (if internal). After booting, the system continues installation, displays the Windows banner, and begins auto detection of mass-storage devices and adapters.

12. Follow the onscreen instructions to complete the installation. When the **Completing the Windows Setup Wizard** screen appears, click **Finish**.
13. Install the latest EMC-approved Windows Service Pack and/or OS patches or updates. Follow the procedures in the Microsoft documentation that accompanies the updates.

Windows 2008 internal or external boot disk installation

This section is a step-by-step procedure for installing a Windows operating system to either an internal or external boot device.

After you have your adapter(s) installed in your server, and configured for external boot if necessary, the next step is to install the Windows operating system. If you intend to boot to an external device, refer to [“Booting from the external storage array” on page 26](#) for setting the boot BIOS for external boot and selecting the external boot LUN.

Note: If you intend to boot to an external disk, present only the LUN from which you intend to boot. All additional LUNs can be added after the installation. This will eliminate confusion on selecting the correct partition for installation and eliminates any problems that the operating system could encounter on reboot during the installation. Also confirm there is only **one** path to the storage array. Having more than one path can cause the operating system to fail during the installation.

To install Windows, you need the following materials:

- ◆ A Windows DVD-ROM for the Windows 2008 you wish to install
- ◆ An EMC-approved adapter driver jump-drive (USB) for Windows

To install Windows:

1. Insert a bootable Windows DVD-ROM into the drive and reboot the system. If your system has a bootable disk already configured from a previous installation, the software will prompt you to press any key to boot from DVD-ROM.
2. If you are installing Windows to boot from an external array disk, you will need to supply setup with the adapter driver in a USB jump-drive and insert it in your server prior to the Windows installation.

The **Windows Boot Manager** screen displays (Figure 39).

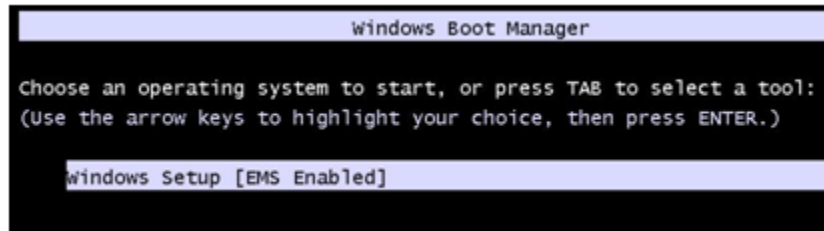

Figure 39 Windows Boot Manager

3. Press **Enter** to continue the installation.

The **Windows Setup** screen displays (Figure 40).



Figure 40 Windows Setup screen

- Click **Next** to continue to the **Windows Install** screen (Figure 41).



Figure 41 Windows Install screen

- Click **Install now** to continue to the **Windows operating system selection** screen (Figure 42).

Select the operating system you want to install.

Operating System	Architecture	Date Modified
Windows Server 2008 Standard (Full Installation)	x86	1/19/2008
Windows Server 2008 Enterprise (Full Installation)	x86	1/19/2008
Windows Server 2008 Datacenter (Full Installation)	x86	1/19/2008
Windows Server 2008 Standard (Server Core Installation)	x86	1/19/2008
Windows Server 2008 Enterprise (Server Core Installation)	x86	1/19/2008
Windows Server 2008 Datacenter (Server Core Installation)	x86	1/19/2008

Description:

This option installs the complete installation of Windows Server. This installation includes the entire user interface, and it supports all of the server roles.



Figure 42 Windows operating system selection screen

6. Choose your operating system type and click **Next** to continue to the **Microsoft Software License Terms** screen (Figure 43).



Figure 43 Microsoft Software License Terms screen

7. Check the **I accept the license terms** checkbox and click **Next** to continue to the **Windows setup** screen (Figure 44 on page 67).

Which type of installation do you want?

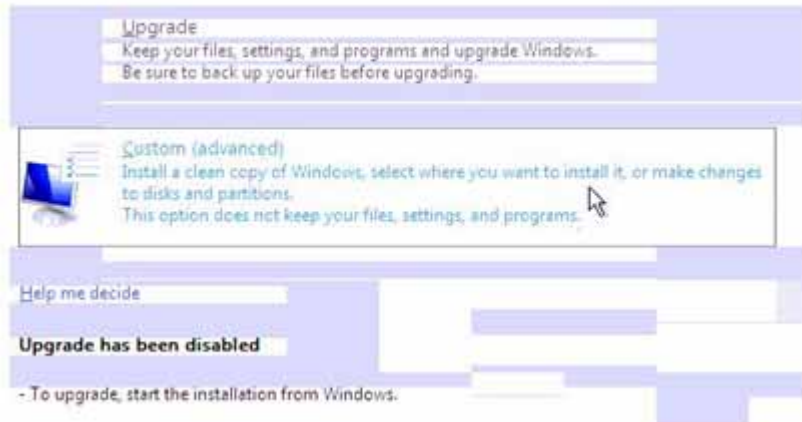

Figure 44 Windows setup screen

- Click **Custom (advance)** if you want to install a clean copy of Windows.

The **Load driver** screen displays (Figure 45).

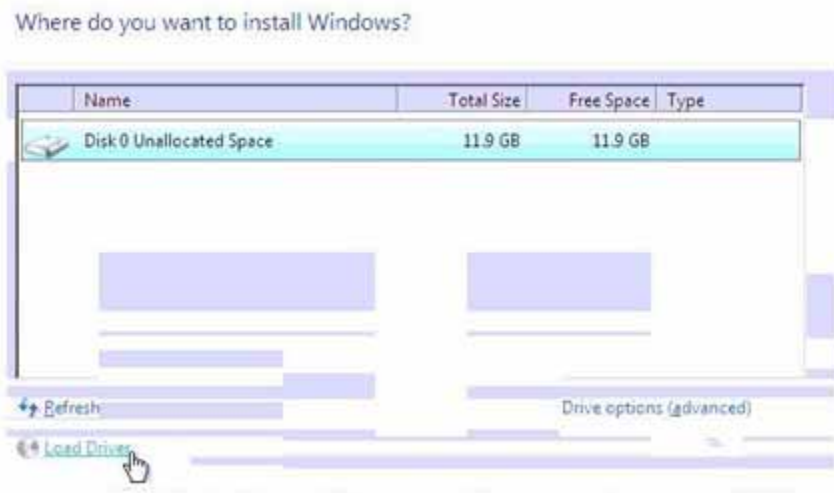

Figure 45 Load driver screen

9. Select **Load Driver** (Figure 45 on page 67) if booting from the external device and then click **Next** to continue.

The **Loading driver** screen displays (Figure 46).

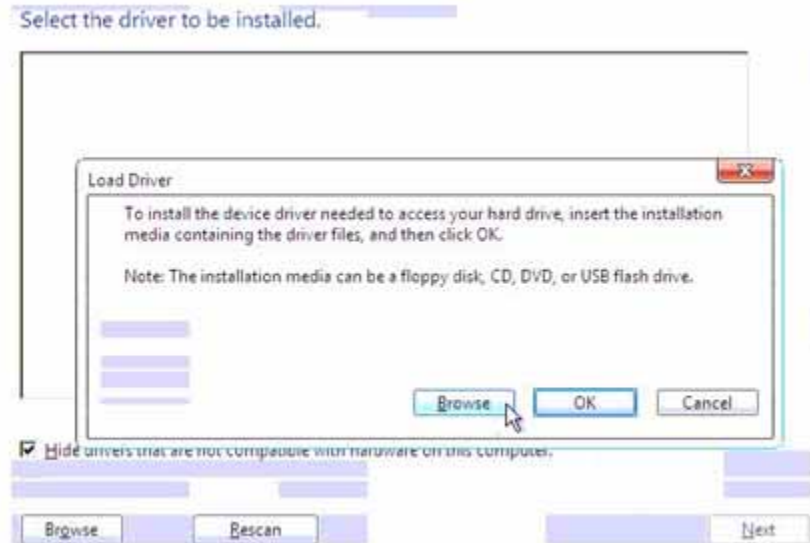

Figure 46 Loading driver screen

10. Click **Browse** to load your adapter driver.

The **Browse for Folder** screen displays (Figure 47).

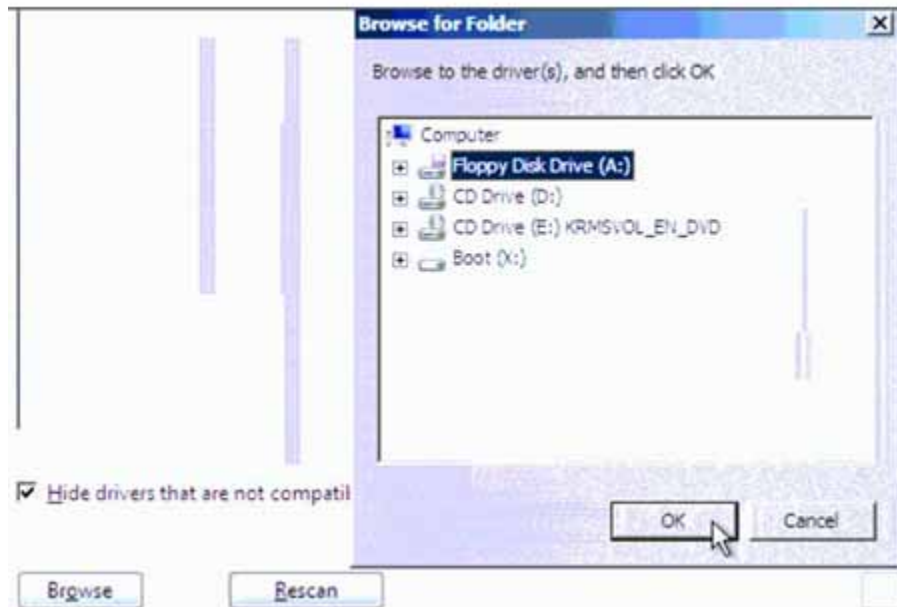

Figure 47 Browse for Folder screen

Note: You would see your USB jump-drive rather than the Floppy Drive A as shown in Figure 47.

11. Select your USB jump-drive (Figure 48).

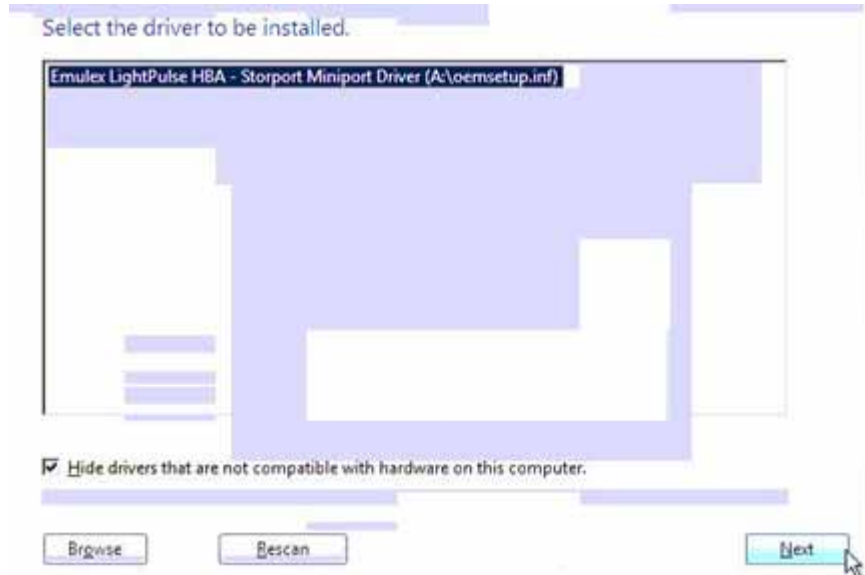

Figure 48 Specifying a driver for your adapter

12. Click **Next** to load your adapter driver.

You will be asked where you want to install Windows (Figure 49).

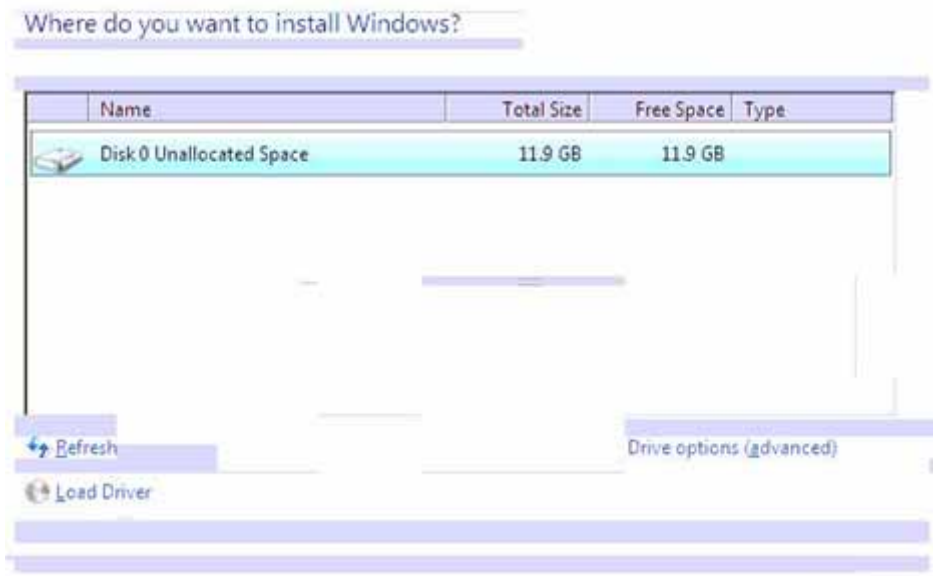

Figure 49 Windows installation prompt screen

Note: Select **Drive Options (advance)** to format your file system.

After the adapter driver is loaded, the **Install Windows** screen displays (Figure 50).

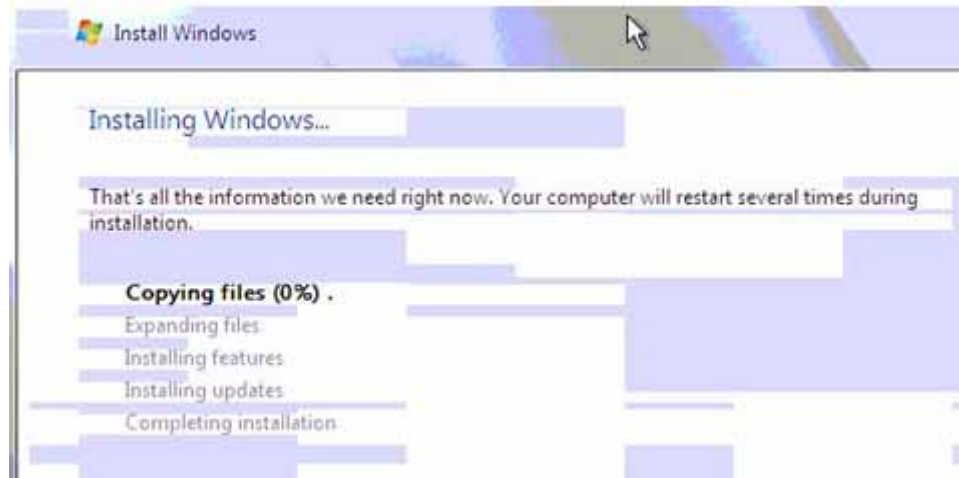

Figure 50 Install Windows screen

13. Click **Next** to begin the Windows installation.

Setup will copy the Windows system files to the partition and start rebooting the server.

14. Do *not* press a key if your system prompts you to "press any key to boot from DVD-ROM." Instead, allow the system to boot from the array (if external) or the local disk (if internal). After booting, the system continues installation, displays the Windows banner, and begins auto detection of mass-storage devices and adapters.

15. Follow the on-screen instructions to complete the installation.

Windows 2008 Server Core operating system option

Windows Server 2008 includes a variation of an installation called a *Server Core*. Server Core is a "scaled-back" installation where no Windows Explorer shell is installed. All configuration and maintenance is done either through the command line interface windows or by connecting to the machine remotely using Microsoft Management Console.

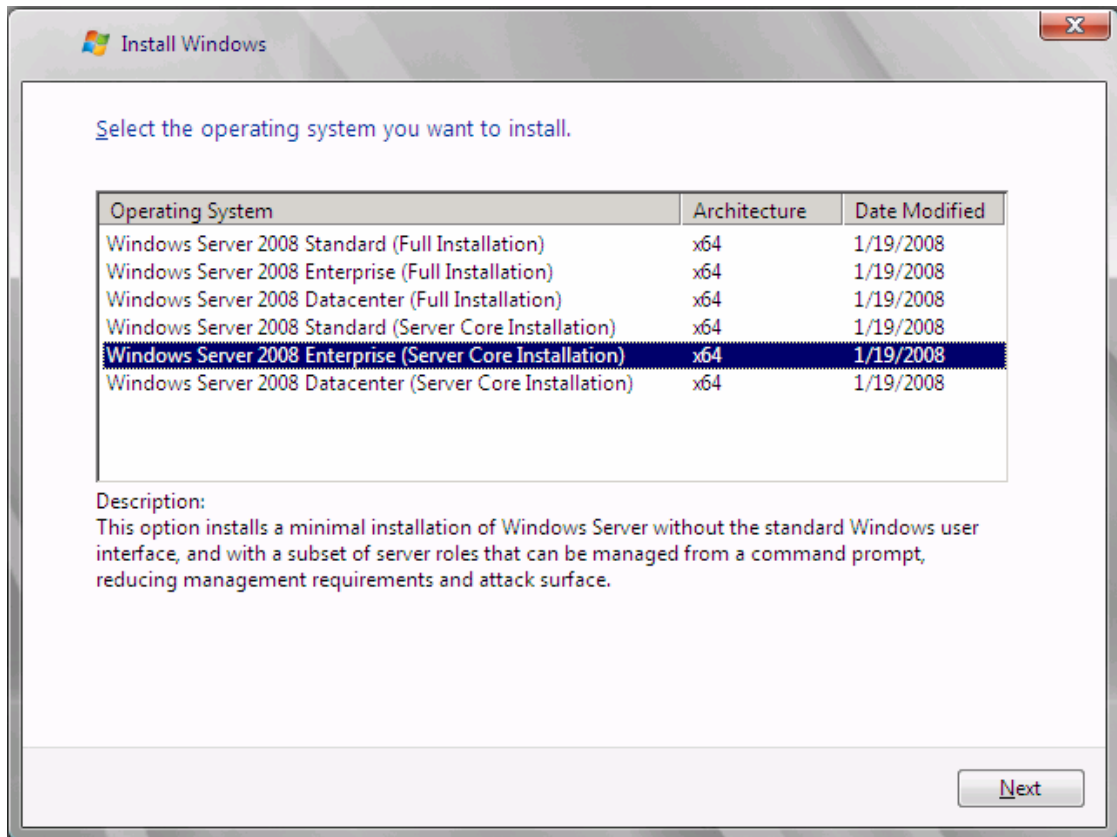

Figure 51 Server Core installation example

Limitations

Since Server Core is a special installation of Windows Server 2008, the following limitations exist:

- ◆ You cannot upgrade from a previous version of the Windows Server operating system to a Server Core installation. Only a clean installation is supported.
- ◆ You cannot upgrade from a full installation of Windows Server 2008 to a Server Core installation. Only a clean installation is supported.
- ◆ You cannot upgrade from a Server Core installation to a full installation of Windows Server 2008. If you need the Windows user interface or a server role that is not supported in a Server Core installation, you must install a full installation of Windows Server 2008.

EMC support

EMC supports the use of Server Core for attach to EMC storage arrays. The currently supported adapter drivers/firmware/BIOS and adapter driver utilities are approved for use with this version of Windows 2008. Use of the QLogic SANsurfer driver install wizard (executable driver package), as shown in [Figure 52](#), works exactly as it will on a standard Windows 2008 installation, but the wizard must be started from the command prompt.

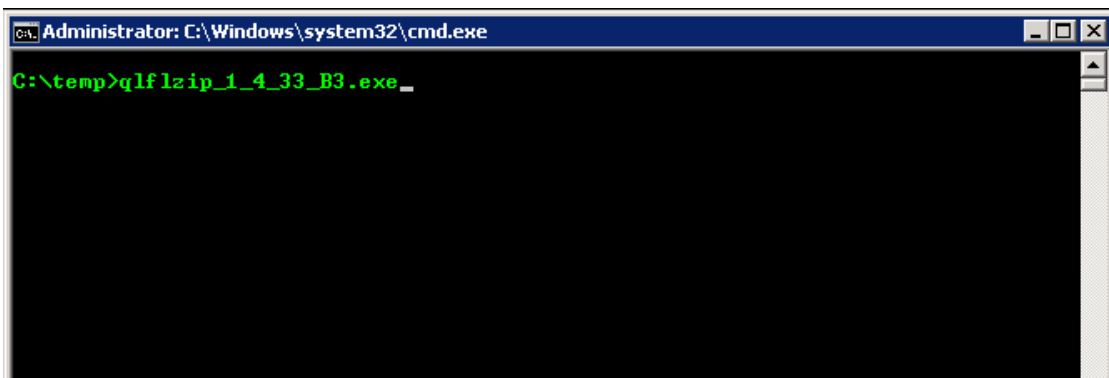

Figure 52 QLogic SANsurfer driver install wizard

Likewise, the QLogic SANsurfer adapter utility must be started from the command line, as shown in [Figure 53](#).

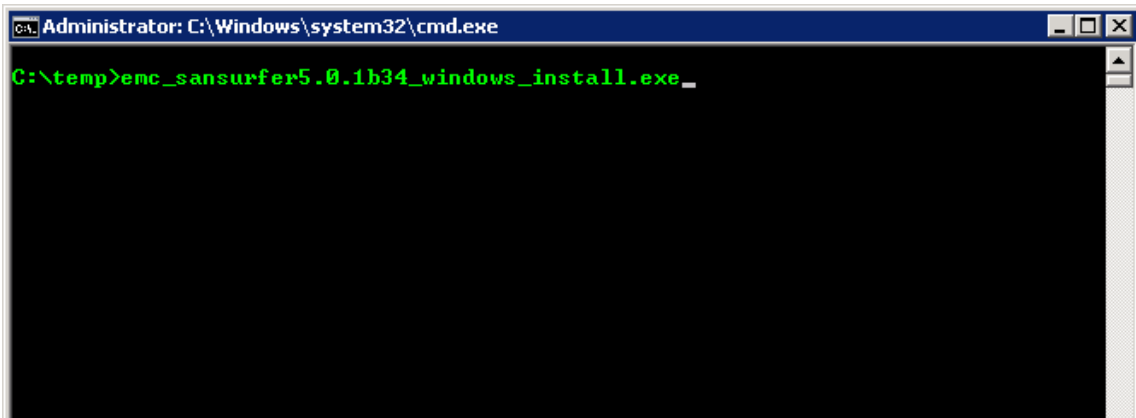

Figure 53 QLogic SANsurfer adapter utility installation

[Figure 54](#) shows SANsurfer utility being started from the command line.

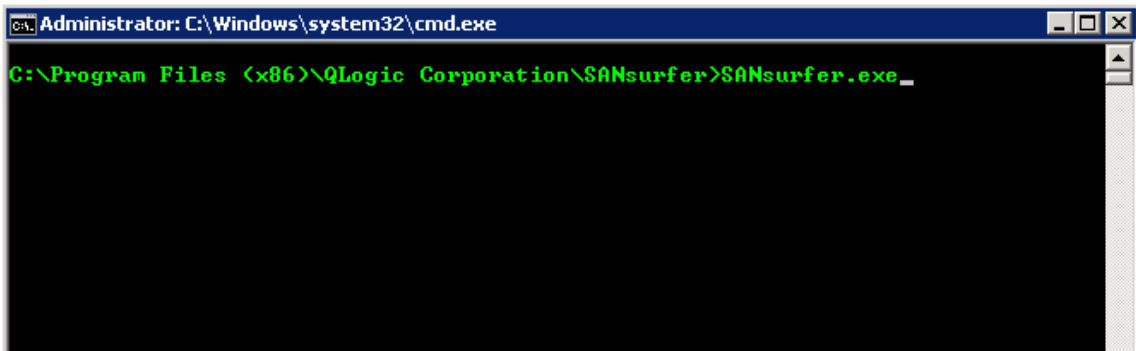

Figure 54 Starting SANsurfer utility from the command line

Once the command has been issued, the installation wizard for the driver and SANsurfer kits will run with a normal installation GUI interface as it would on a standard Windows 2008 installation.

Installing adapter driver and software utilities

To use EMC storage array disks with a Windows 2000, 2003, or 2008 host, you need a Fibre Channel host adapter driver. The driver and related utilities must be installed and configured before Windows can access the EMC disks. This driver can be installed using the QLogic SANsurfer Install Wizard for Windows.

For Windows 2003, EMC supports both the STORPort driver class and the SCSIPort driver class. Windows 2000 uses only the SCSIPort driver class. Windows 2008 uses only the STORPort driver class.

Three sections are outlined on the following pages to help with installation and configuration of your adapter drivers and associated utilities:

- ◆ [“Pre-installation guidelines”](#) , next
- ◆ [“Driver installation/upgrade”](#) on page 77
- ◆ [“Post-installation procedures”](#) on page 86

Pre-installation guidelines

Required Windows STORPort updates

Currently, the shipping version of Windows requires post-RTM hot fixes to resolve some known issues. For all Windows STORPort installations, you must obtain the current Microsoft QFE hotfix listed in the [EMC Support Matrix](#) with the adapter driver revisions.

IMPORTANT

Install this QFE before installing the adapter driver.

Users planning to upgrade to the latest service pack for Windows should upgrade their adapter drivers to the latest supported version prior to installing the service pack. The Windows Service Packs do not contain the latest EMC-approved driver revisions. Always consult the [EMC Support Matrix](#) for the most up-to-date information.

Obtaining the QLogic SANsurfer Install Wizard for Windows

The SANsurfer Install Wizard for Windows is available on CD-ROM or downloaded from the QLogic website. To download from the website:

1. If downloading from the QLogic website, first create a directory that will be used to save the SANsurfer Install Wizard for Windows file.

2. Go to <http://www.qlogic.com>.
3. Select **Downloads** at the top of the page.
4. Select **EMC** under OEM models.
5. Select the link containing your EMC storage.
6. Select the adapter you installed in your system and download the SANsurfer Install Wizard for Windows.

Driver installation/upgrade

1. Install the SANsurfer Install Wizard for Windows Kit CD-ROM to start the SANsurfer HBA Install Wizard. If you downloaded the kit to your hard drive locate and double-click the file. The wizard, shown in [Figure 55](#), will extract needed files from the installation kit.

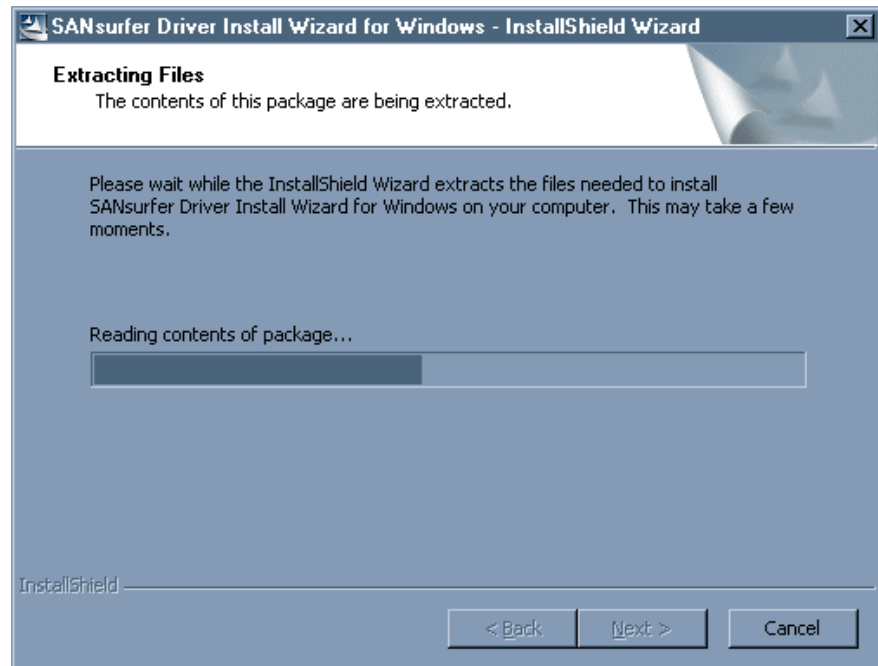

Figure 55 SANsurfer Driver Install Wizard for Windows

2. After the wizard initializes, you will be given several options, as shown in [Figure 56](#). Click **Update Driver** to begin the driver installation.

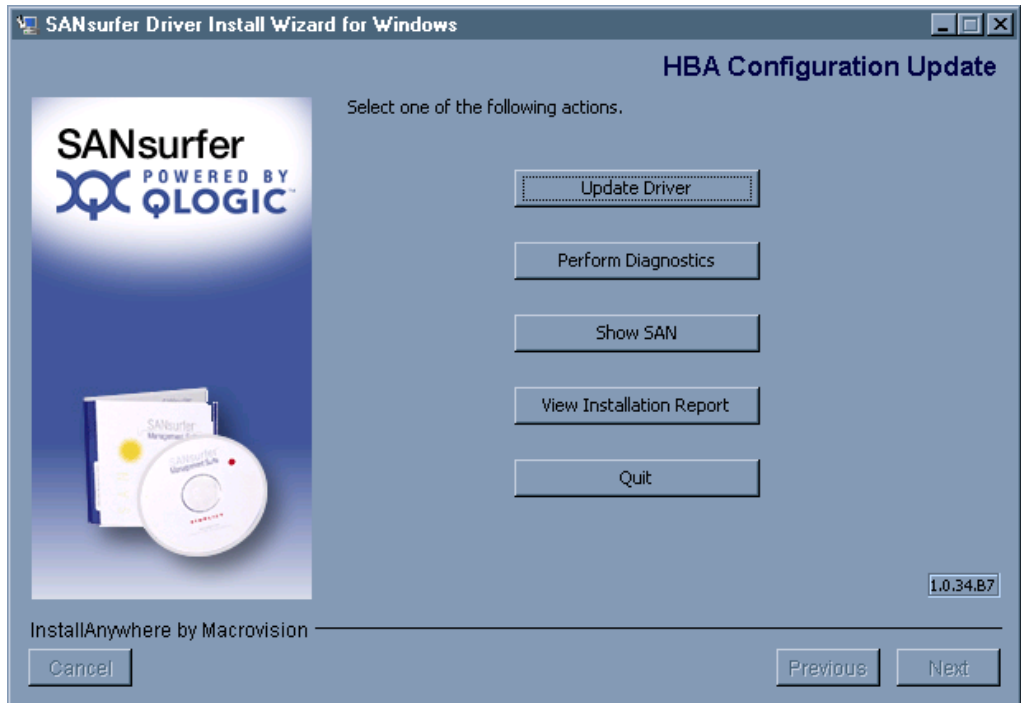

Figure 56 HBA Configuration Update dialog box

The **Select Driver Installation type** dialog box appears, as shown in [Figure 57](#) on page 79.

3. Select **I want to install the driver automatically**.

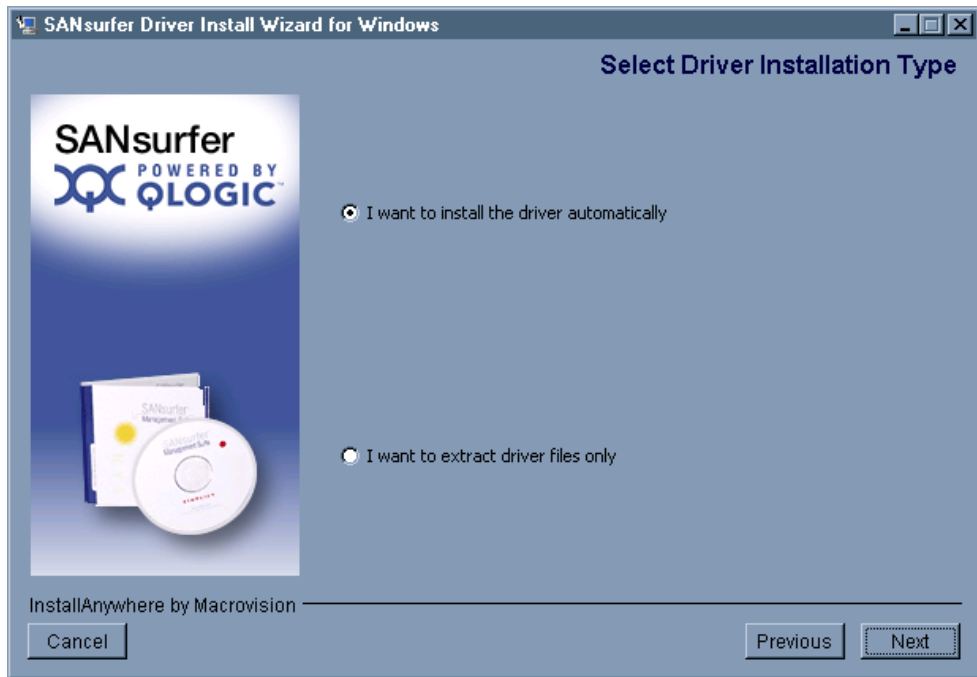

Figure 57 Select Driver Installation Type dialog box

Note: If you are upgrading your adapter driver, you will be taken to the **HBA Configuration Update** screen shown in [Figure 56 on page 78](#). At this point, click the **Update Driver** button. You will be taken to the **Select Driver Installation Type** screen shown in [Figure 57 on page 79](#). Select the driver you wish to install, and proceed with the procedure at [Step 4 on page 81](#).

The **Select a Driver Location** dialog box appears, as shown in [Figure 58 on page 80](#).

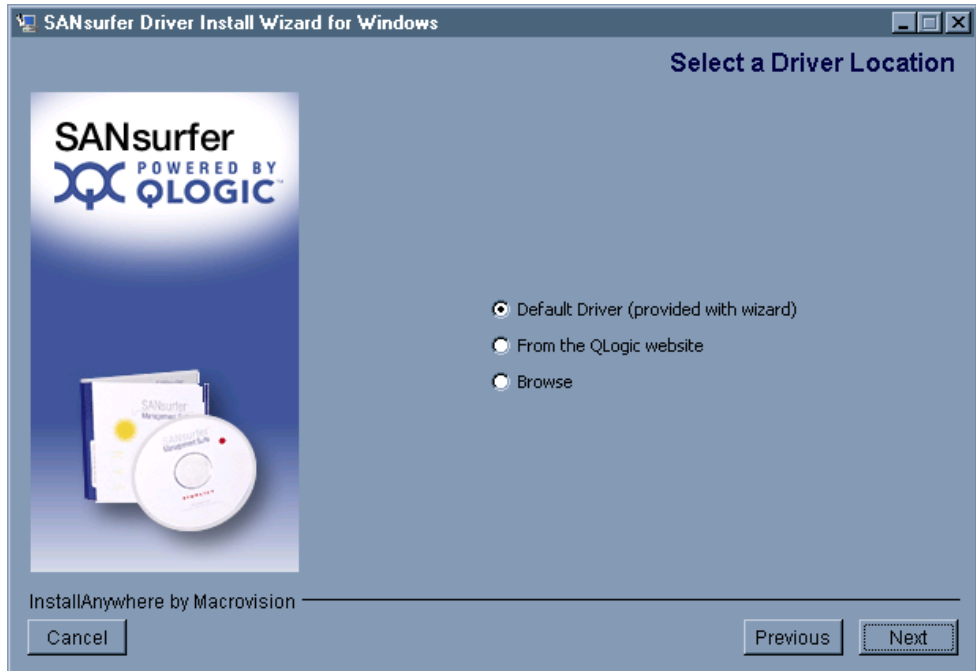

Figure 58 SANSurfer driver location dialog box

This window presents three choices:

- **Default Driver**
This is the default selection. This selection will use the driver located on the CD-ROM or the SANSurfer Install Wizard for Windows file. Use this option if you downloaded the kit from the QLogic website.
- **From the QLogic website**
The selection will automatically search the QLogic website for the latest driver. An Internet connection is required. Use this selection if you are upgrading your adapter drivers to a newer version.
- **Browse**
Use this option if you previously downloaded the driver file and stored it on your hard drive.

4. Click **Next** to continue. A message similar to the following will appear:

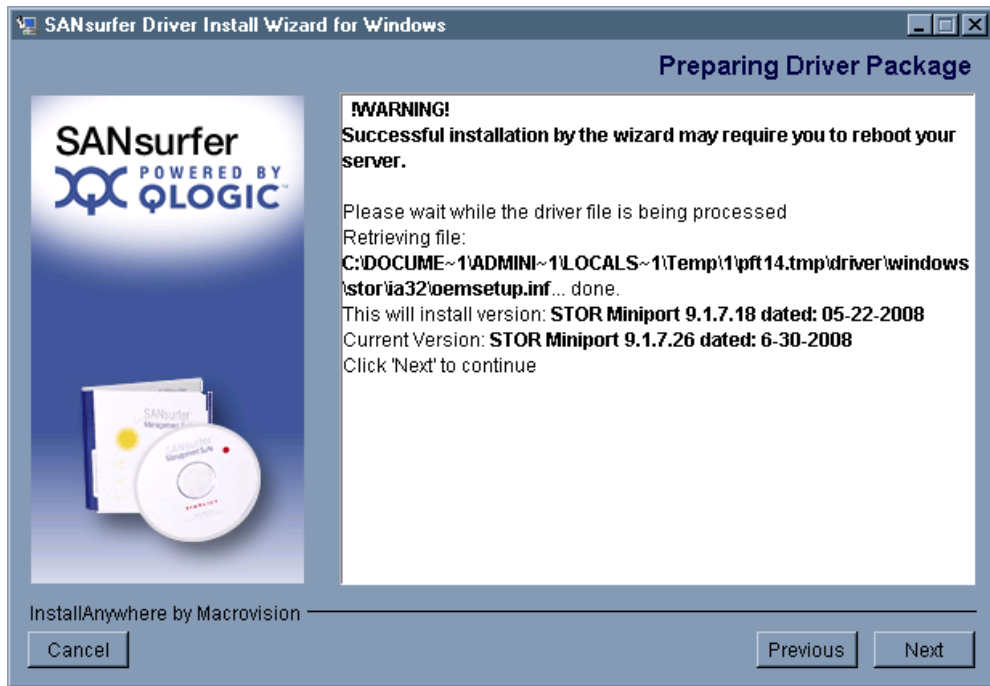

Figure 59 SANsurfer installation with version number

- The wizard displays a summary screen, as shown in [Figure 60](#), describing the actions it will take during the driver installation and the version of driver to be installed. Note that the server may require a reboot after the driver load. Click **Next** to start the installation.

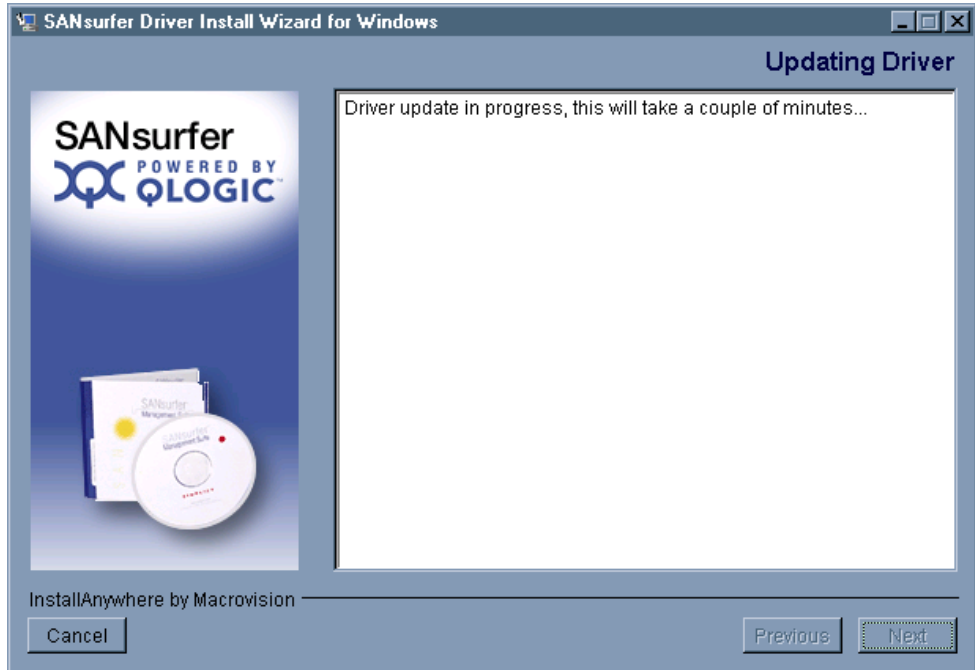

Figure 60 Updating Driver dialog box

Note: Depending on the number of installed adapters, the driver installation may take a couple of minutes.

6. If this is *not* a new installation, the message in [Figure 61](#) may appear. Check the **Stop QLogic Management Suite Java Agent Service** checkbox and click **Next**.

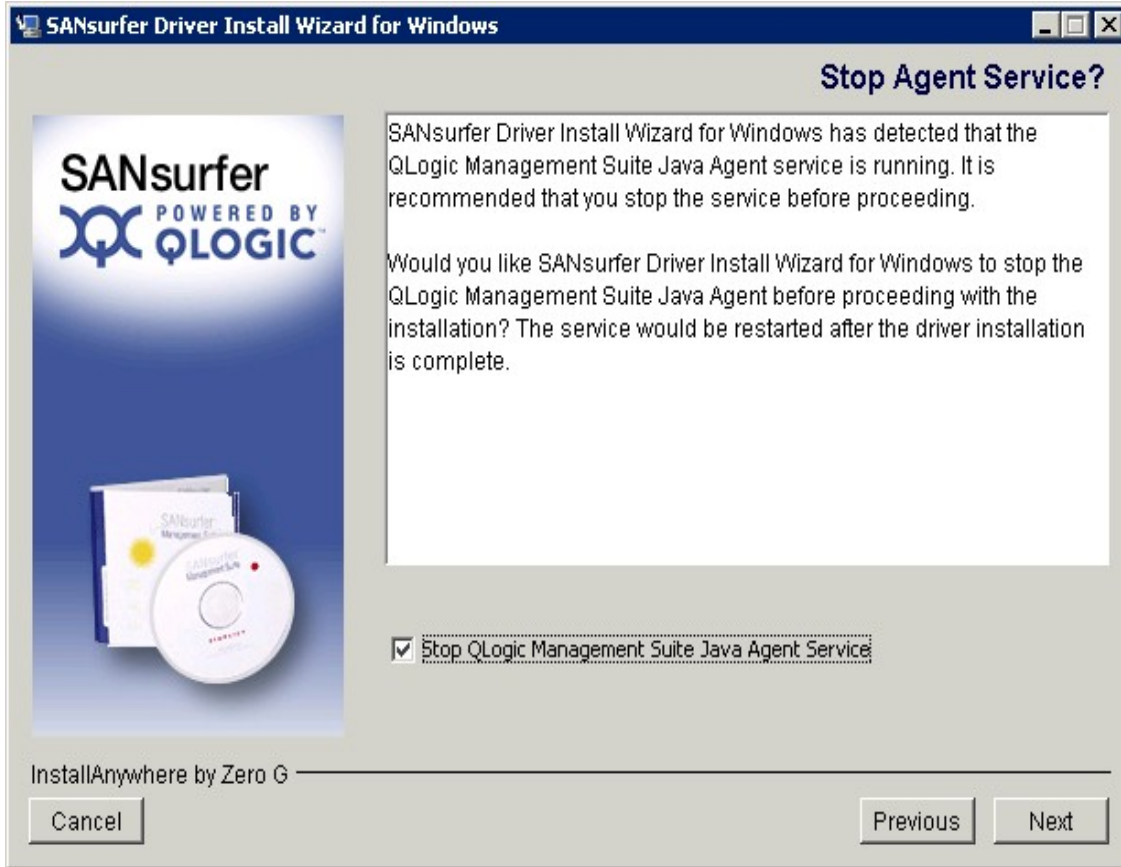

Figure 61 SANsurfer Java agent service message

The **Installing Driver** dialog box, shown in [Figure 62](#), appears.

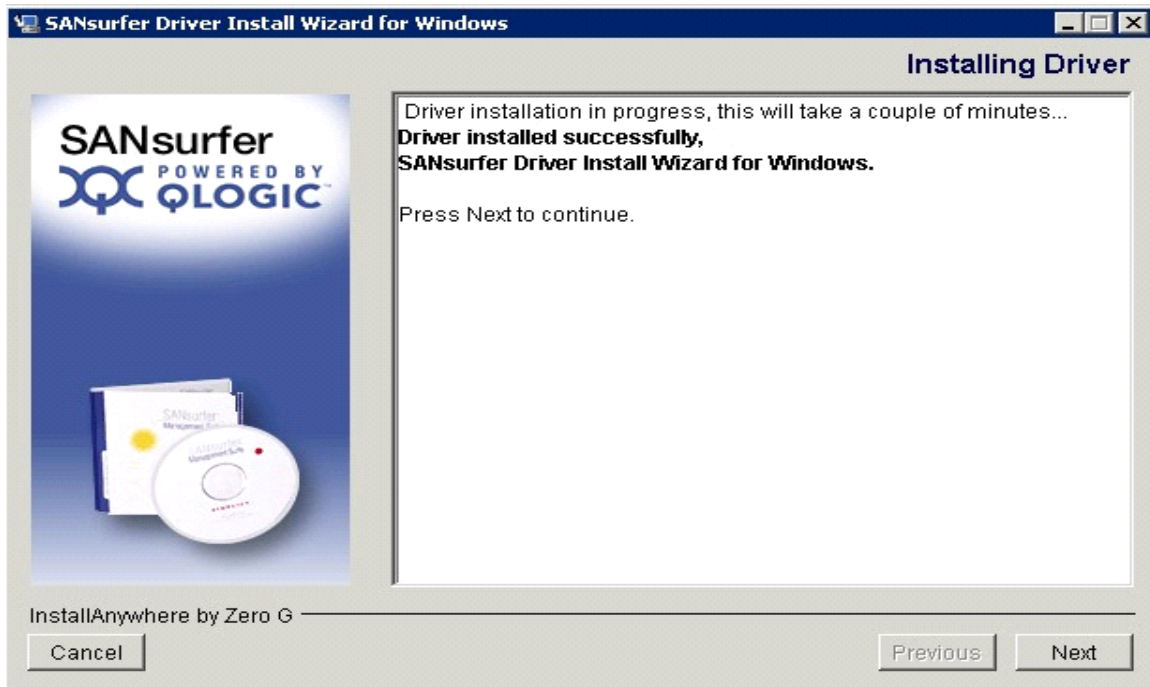

Figure 62 Installing Driver dialog box

- When the driver installation completes, the **Driver installed successfully** message appears, as shown in [Figure 63](#). Click **Next** to continue.

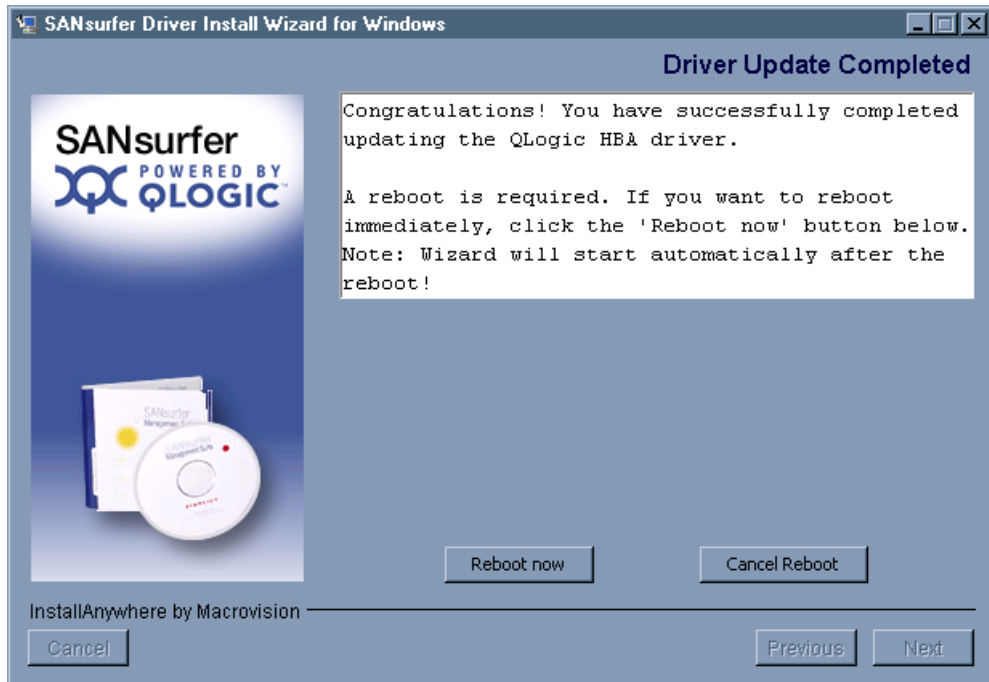

Figure 63 Driver Update Completed dialog box

- If a reboot is required, the wizard will give you the option of rebooting, or canceling the reboot and continuing with the wizard. If you cancel the reboot, click **Next** to continue back to the configuration update screen.

9. The **HBA Configuration Update** screen, shown in [Figure 65](#), will appear after the driver installation is complete. From here, you may perform diagnostic procedures or other post-installation tasks. If you are finished with your adapter update, click **Quit**.

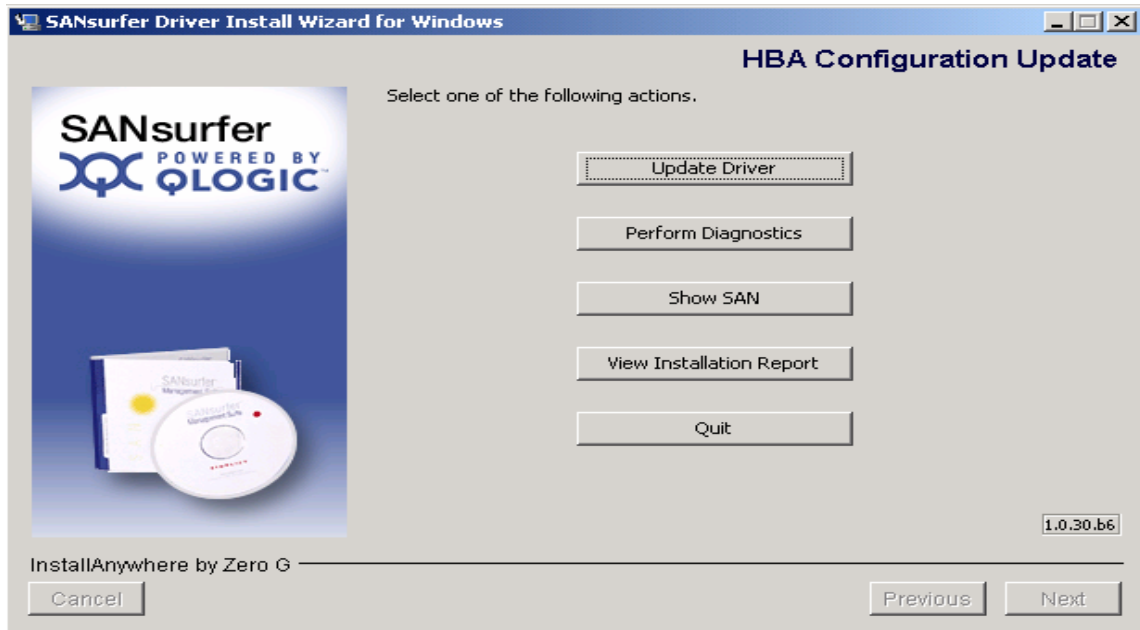

Figure 64 HBA Configuration update dialog box

Post-installation procedures

- Diagnostics**
1. From the **HBA Configuration Update** screen, click **Perform Diagnostics** (refer to [Figure 64](#)). The **SANsurferHBA Install Wizard** window will appear, as shown in [Figure 65](#) on page 87.

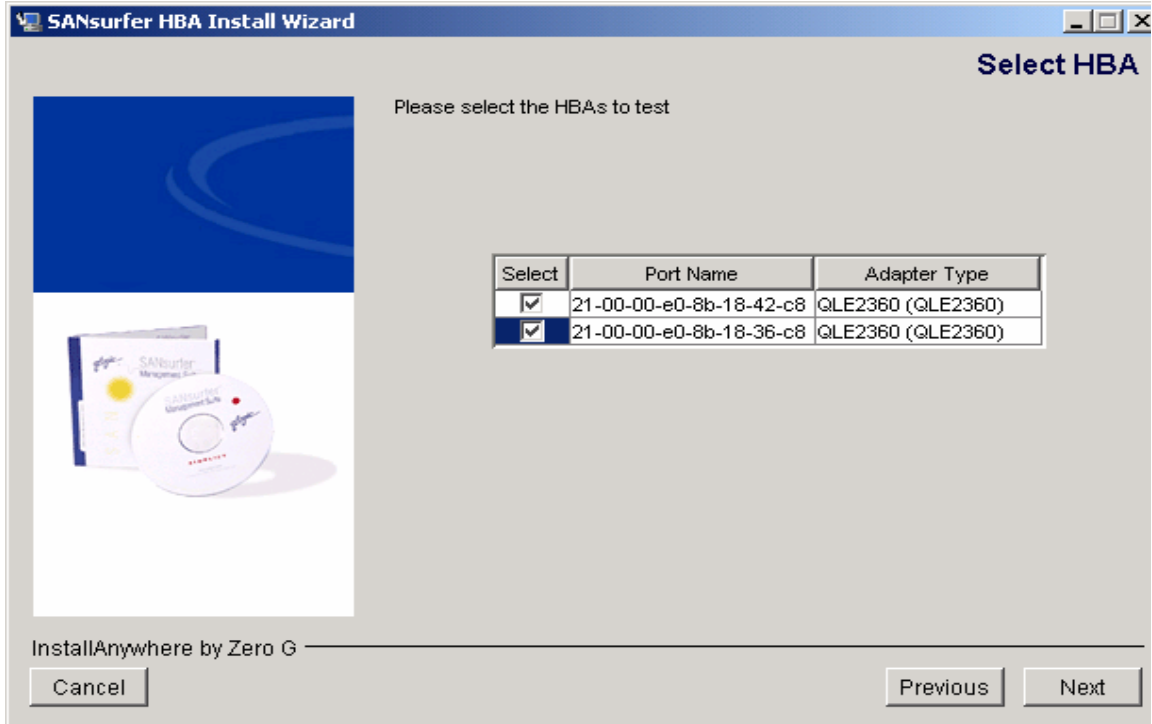

Figure 65 Select HBA dialog box

2. Select the adapters to be tested and select **Next**.

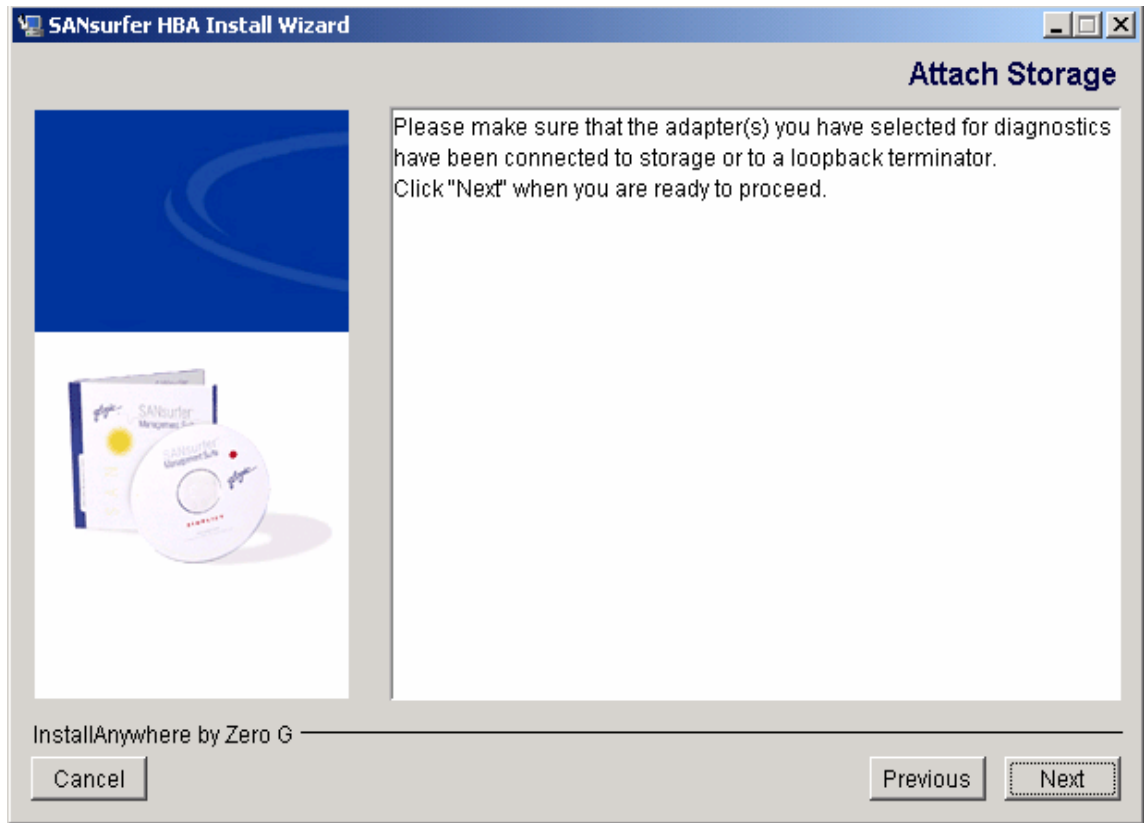

Figure 66 Attach Storage dialog box

3. Ensure that the adapters you selected for diagnostics are connected to storage or to a loopback terminator. Click **Next** to run the test.

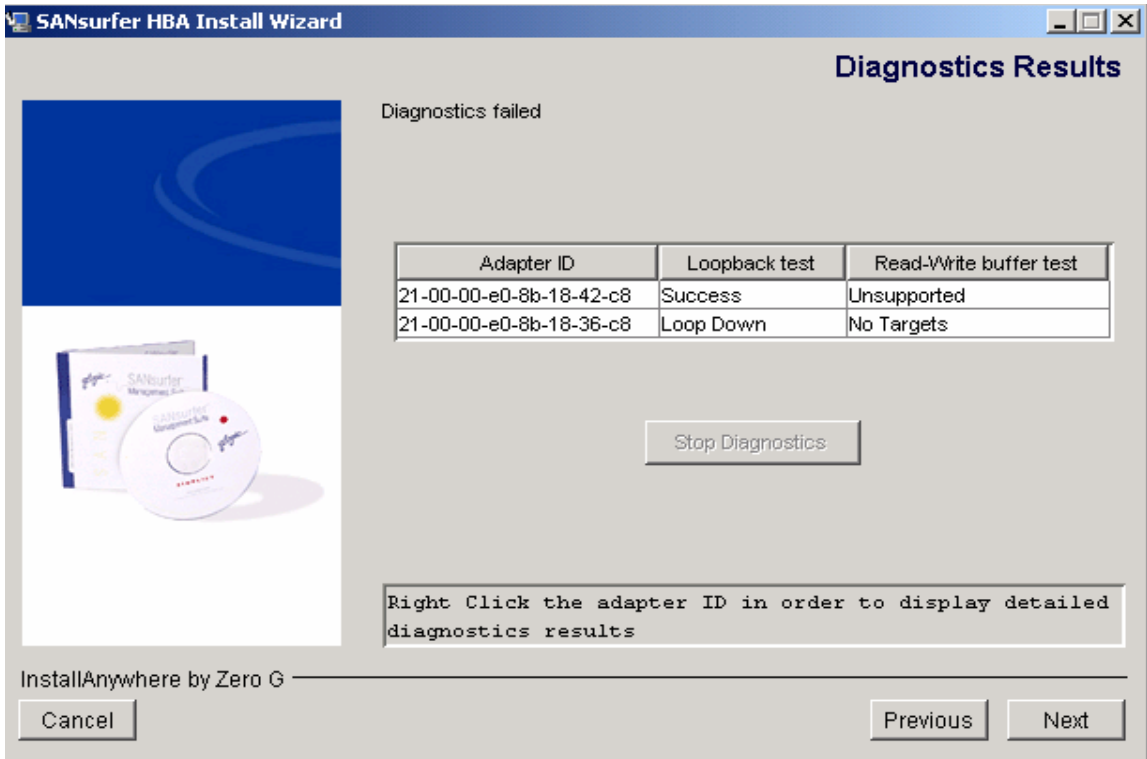

Figure 67 Diagnostics results dialog box

- The next window will display the diagnostics results. More information on this tool is available at the QLogic website www.qlogic.com. Select **Next** to return to the main menu.

Show SAN

Figure 68 shows the SAN tree.

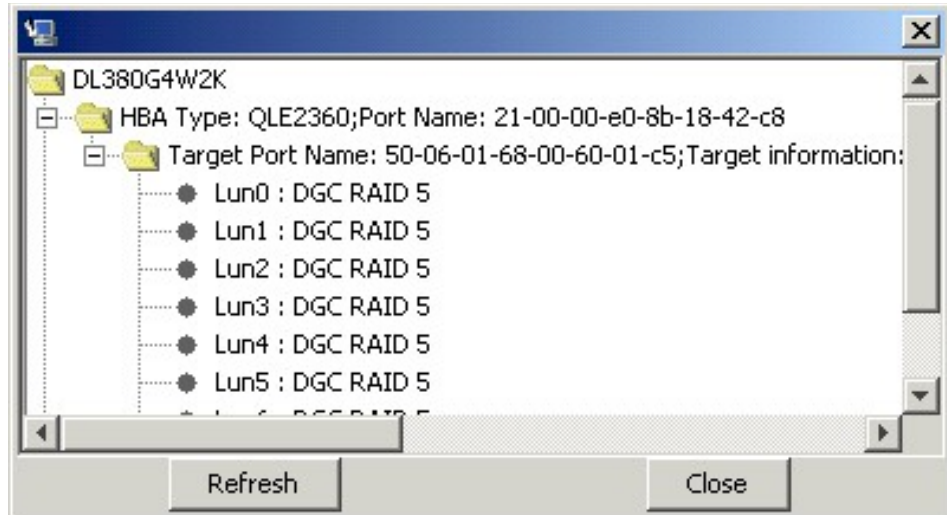

Figure 68 Show SAN tree

The **Show SAN** feature is useful for verifying connectivity to the storage array.

FCoE converged network adapter (CNA) procedures

This section provides the following information on FCoE converged network adapters:

- ◆ [“Overview” on page 91](#)
- ◆ [“Installing Fibre Channel BIOS and firmware on a QLogic CNA” on page 93](#)
- ◆ [“Installing Menlo firmware on a QLogic CNA” on page 97](#)
- ◆ [“Installing or upgrading the driver and utilities on a QLogic QLE8242 CNA” on page 101](#)
- ◆ [“Updating adapter firmware on a QLogic QLE8242 CNA” on page 105](#)
- ◆ [“Configuring QLogic FAST!UTIL 10 GbE iSCSI BIOS/boot LUN settings for QLE8242 iSCSI adapters” on page 117](#)

Overview

FCoE converged network adapters (CNAs) are similar to Fibre Channel adapters in that they require drivers in order to function in a Windows server. However, because of its ability to converge both Fibre Channel and Ethernet traffic over a single physical link, the adapter will appear to the Windows server as two different pieces of hardware. When viewing the Windows Device Manager, you will see both a QLogic Fibre Channel adapter as well as an Intel 10 Gigabit network adapter available in the system, as shown in [Figure 69 on page 92](#).

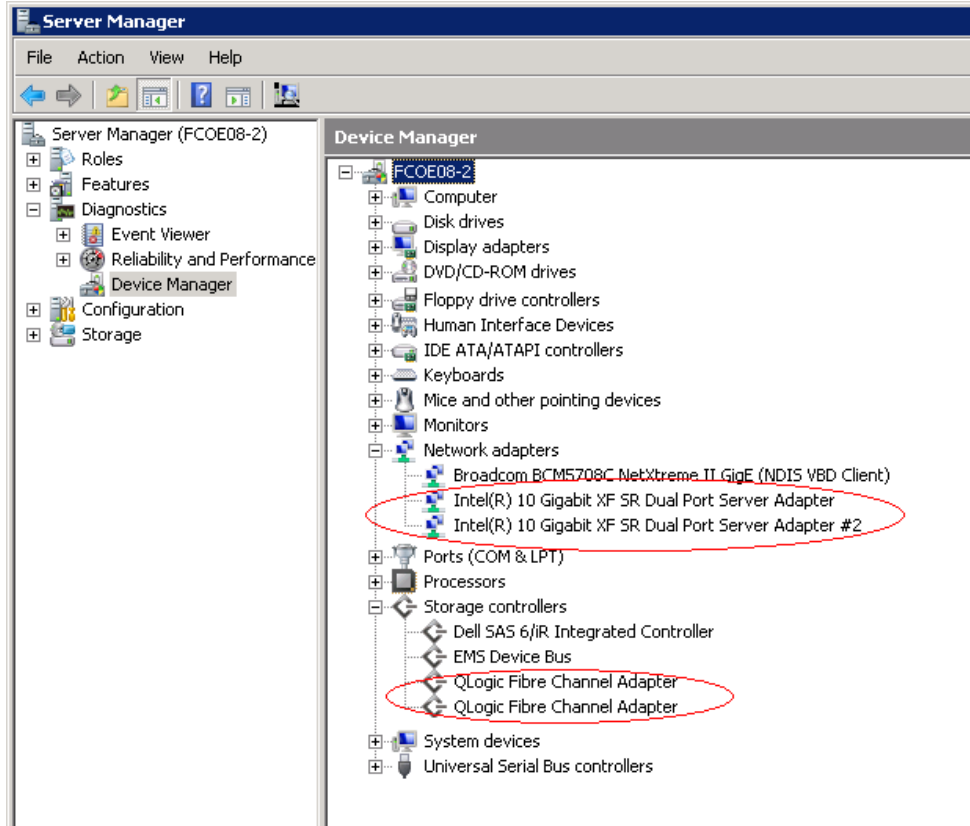

Figure 69 Device Manager

Both of these hardware devices require a driver in order to function. For the Fibre Channel adapter, the same procedure that is used to install drivers on standard Fibre Channel adapters, described in “[Installing adapter driver and software utilities](#)” on page 76, can be used.

For the Intel 82598 10 Gigabit Ethernet Controller, visit <http://www.intel.com> for drivers and information on driver installation for this network adapter.

FCoE adapters also require BUIOS and firmware code for the Fibre Channel adapter, as well as for the encapsulation ASIC known as the Menlo chip. To update these BIOS and firmware versions, the QLogic SANsurfer utility must be used. The minimum SANsurfer version for

use with FCoE adapters is v5.0.1 build 34 and is packaged with the EMC-approved driver for the FCoE adapter.

Installing Fibre Channel BIOS and firmware on a QLogic CNA

To install the Fibre Channel firmware on your FCoE converged network adapter, start the SANsurfer utility, shown in [Figure 70](#), and then follow these steps:

1. In the left pane of the utility, you will see the CNA listed under your server host name. Click open the CNA and click on the appropriate port number in order to view all of the possible options in the right pane of the utility.

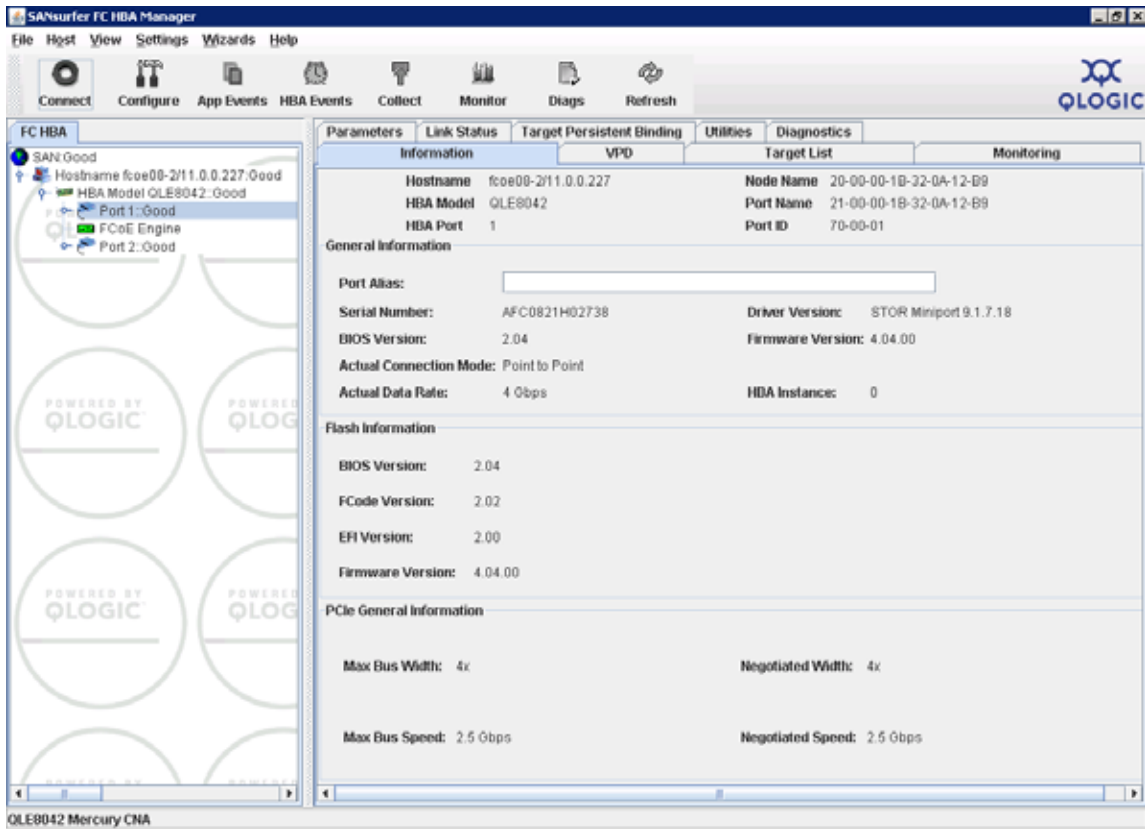

Figure 70 SANsurfer utility

2. Click **Utilities** in the right pane of the SANsurfer utility.
3. Under the **Utilities** tab, shown in [Figure 71](#), you will see several sections that allow you to update the CNA flash, HBA parameters, and the CNA driver. To update the Fibre Channel BIOS and firmware of the adapter, click **Update Entire Image**.

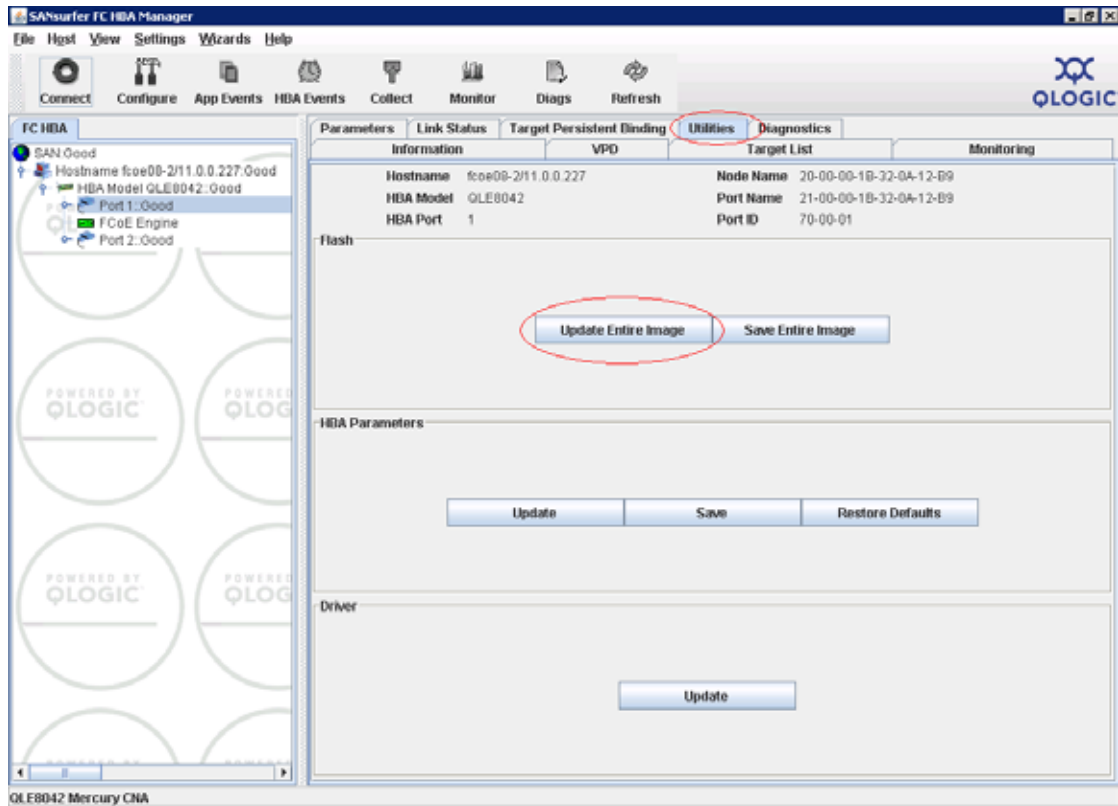

Figure 71 Utilities tab

4. An **Open** dialog box displays, as shown in [Figure 72](#) on page 95. Browse to the location of your firmware file that you wish to load. This file could be included on EMC-Approved installation media, or can be downloaded from the QLogic website as described “[Downloading latest QLogic drivers/firmware/BIOS files](#)” on page 16.

Note: This file, known as the multiboot image, contains the BIOS, FCode, and firmware for the adapter. This process will flash all of this code to the adapter simultaneously.

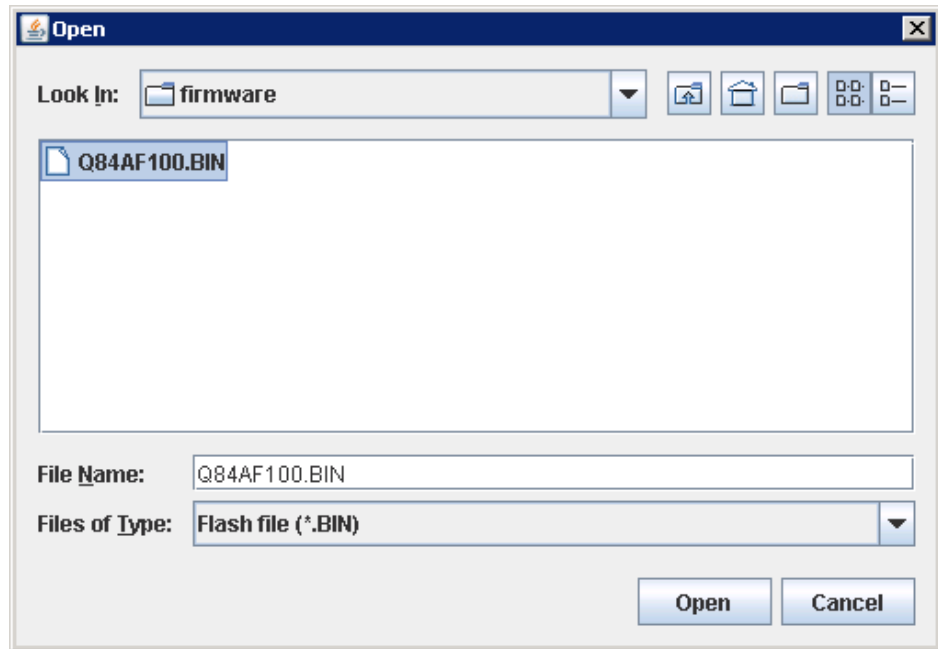

Figure 72 Open dialog box

5. After locating your firmware file, click **Open**.
6. Depending on whether you have done other configuration changes to your adapter, you may be asked for the password to make changes, as shown in [Figure 73 on page 96](#).

The default password is *config* and if you leave the **save password for the current session** box checked, you will not be required to reenter this password later unless you close SANsurfer.

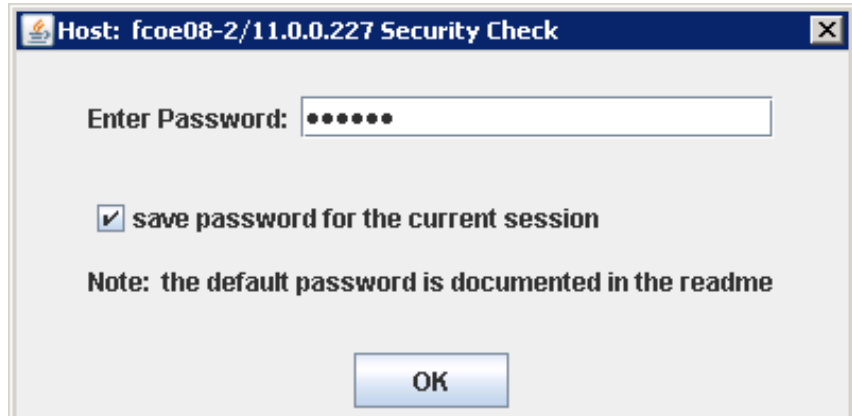

Figure 73 Security Check dialog box

7. SANsurfer may appear to be unresponsive while the adapter flash memory is being updated. A message will appear when the process is complete, as shown in [Figure 74](#).

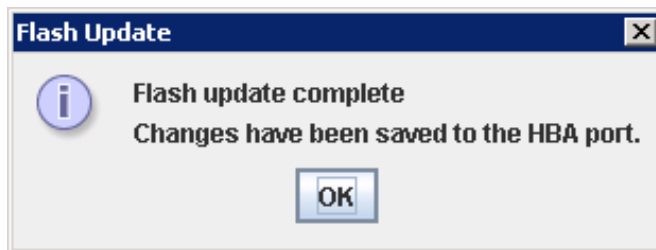

Figure 74 Flash Update dialog box

8. Click **OK** to complete the BIOS/firmware update procedure.

If you have other CNAs installed in your server, or second paths on the same CNA, select them in the left pane of the SANsurfer utility and follow this procedure for each CNA you need to update.

Installing Menlo firmware on a QLogic CNA

To install the Menlo encapsulation ASIC firmware on your FCoE converged network adapter, follow these steps.

1. Start the SANsurfer utility, as shown in [Figure 75](#), and click **Open your CNA**.
2. In the left panel, under the CNA, click the **FCoE Engine**.
3. In the right pane of the SANsurfer utility, you will see information about the CNA Menlo firmware.

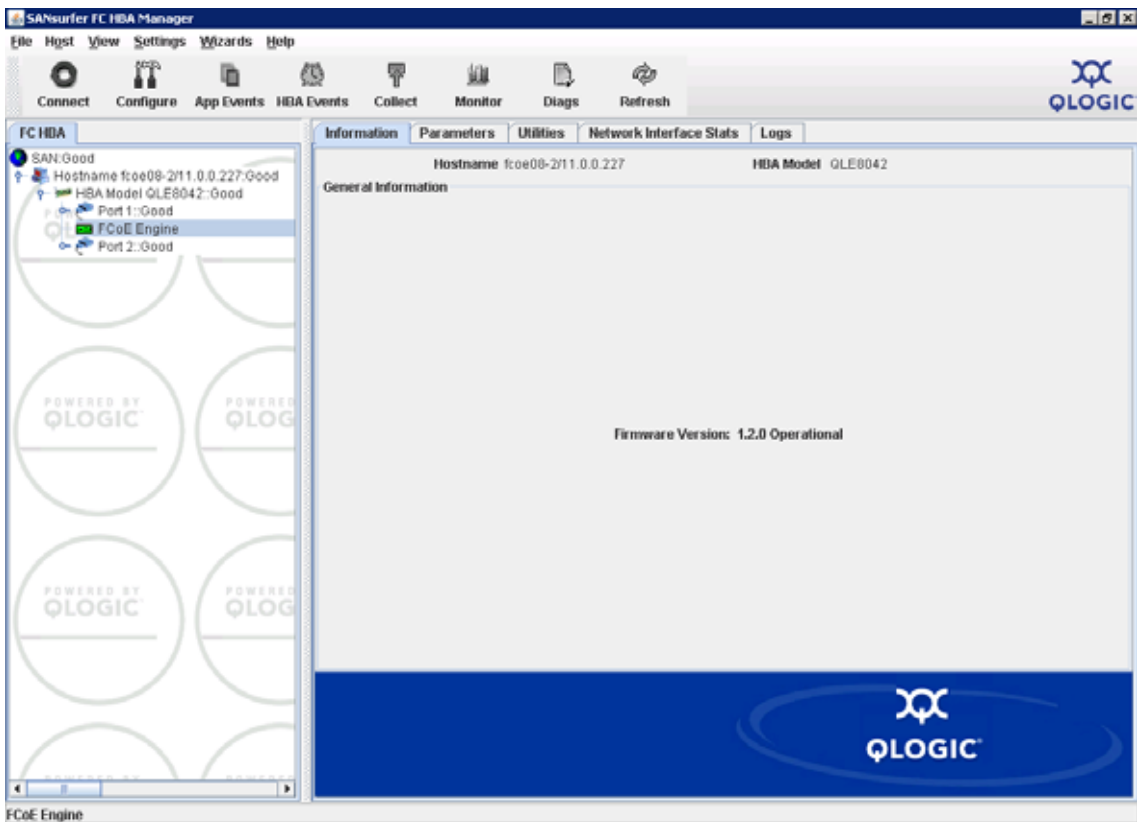

Figure 75 SANsurfer utility

- To update the Menlo firmware of the adapter, click the **Utilities** tab and then click **Update Firmware**, as shown in [Figure 76](#).

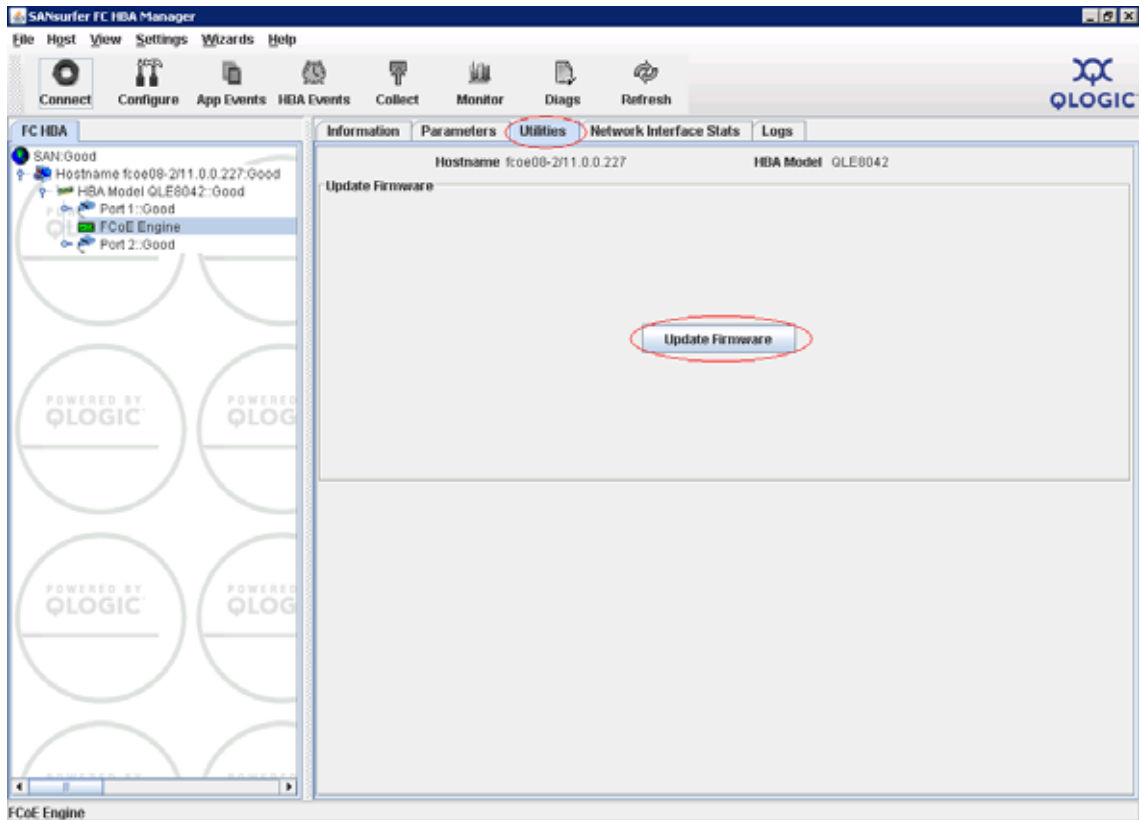

Figure 76 Utilities tab

- A new window appears, as shown in [Figure 77 on page 99](#).
- In this window, browse to the location of the firmware file that you wish to load. This file could be included on EMC-Approved installation media, or can be downloaded from the QLogic website as described in "[Downloading latest QLogic drivers/firmware/BIOS files](#)" on page 16.

7. After locating your firmware file, click **Open** to flash the firmware file to the CNA Menlo chip.

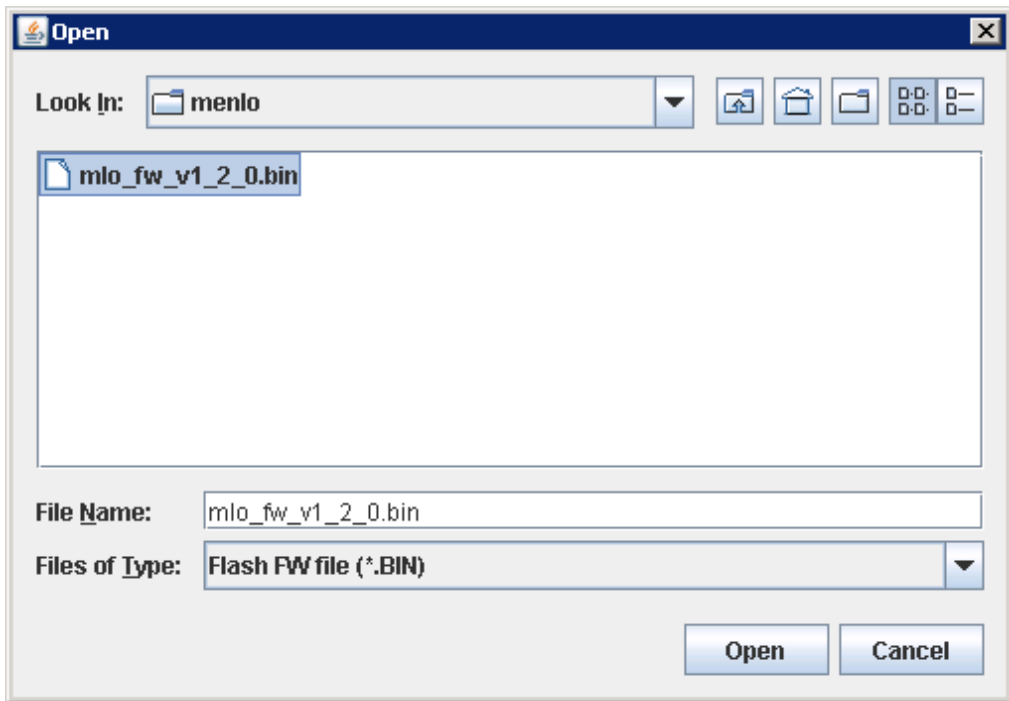

Figure 77 Open dialog box

8. Depending on whether you have done other configuration changes to your adapter, you may see a dialog box asking for the password to make changes.

The default password is *config* and if you leave the **Save password for the current session** box checked, you will not be required to reenter this password later unless you close SANsurfer.

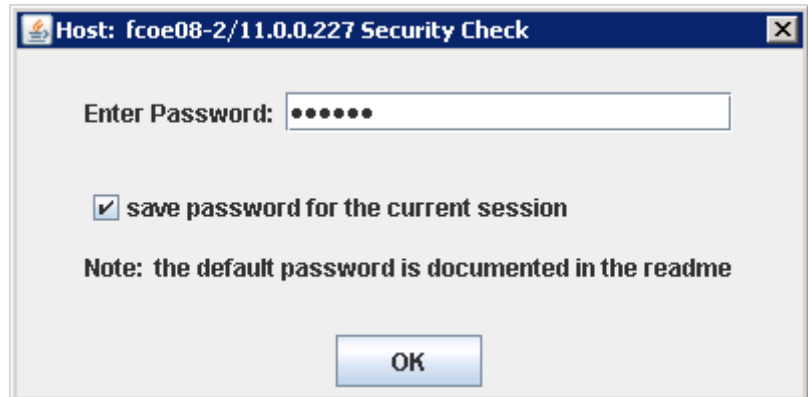

Figure 78 Security Check dialog box

9. SANsurfer may appear to be unresponsive while the adapter flash memory is being updated. A message will appear when the process is complete, as shown in [Figure 79](#).
10. Click **OK** to complete the BIOS/firmware update procedure.

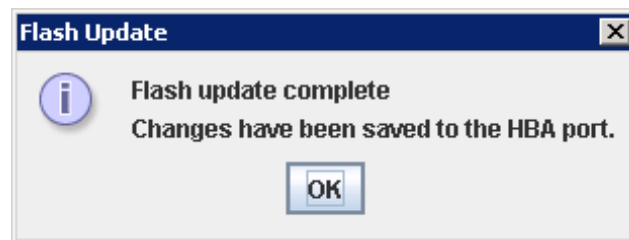

Figure 79 Flash update dialog box

If you have other CNAs installed in your server, select them in the left pane of the utility and follow this procedure for each CNA you need to update.

Note: EMC recommends rebooting your server after completing firmware updates to your adapter.

Installing or upgrading the driver and utilities on a QLogic QLE8242 CNA

To install or upgrade the driver and utilities on a QLogic QLE8242 CNA, complete the following steps.

1. Download the driver kit installer from the QLogic website in the EMC section and install it on your system. If you have downloaded the kit to your hard drive, locate then double-click the file.

The **QConverged Console Driver Install Wizard** displays, as shown in [Figure 80](#).

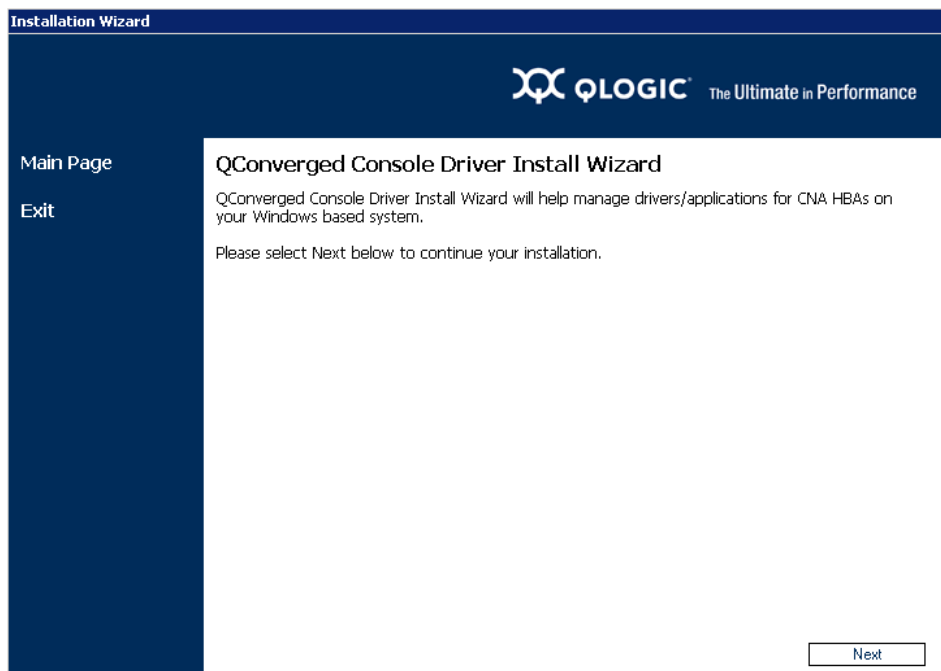

Figure 80 QConverged Console Driver Install Wizard

2. Click **Next** to start the installation.

The **End User License Agreement** displays, as shown in [Figure 81](#).

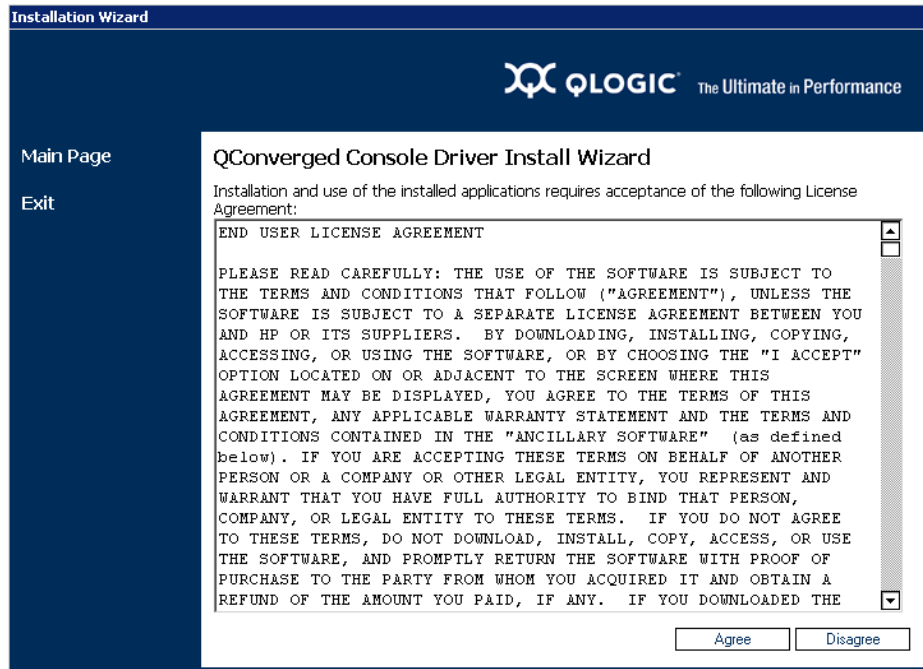

Figure 81 End User License Agreement

3. After reading the agreement, click **Agree**.

The next window displays installation options, as shown in [Figure 82](#).

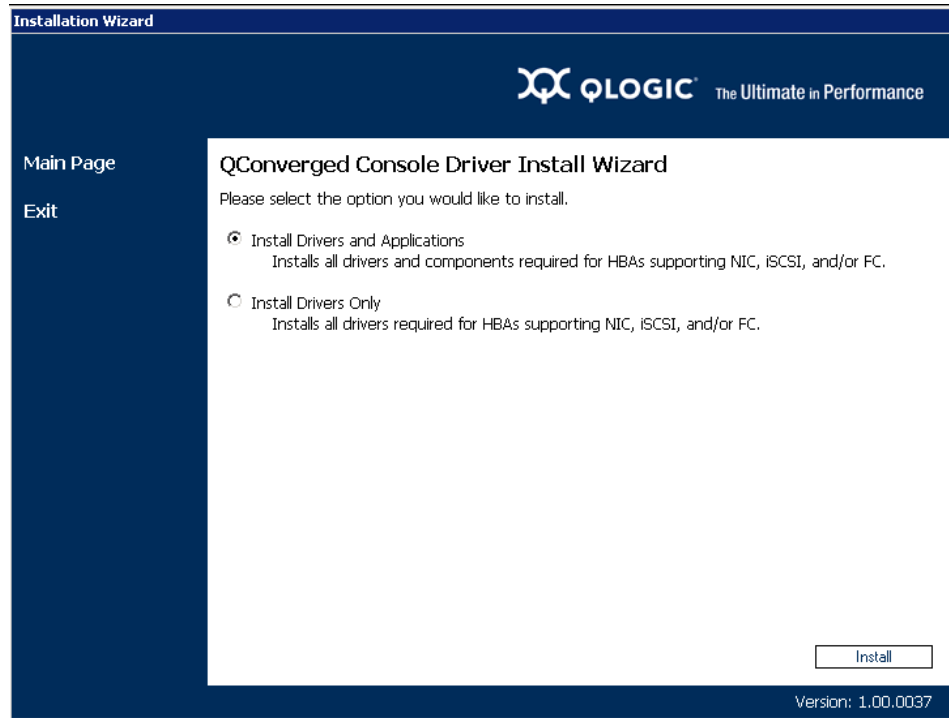

Figure 82 Installation options

4. Select **Install Drivers and Applications** and click **Install**.

The next window displays the installation progress, as shown in [Figure 83](#).

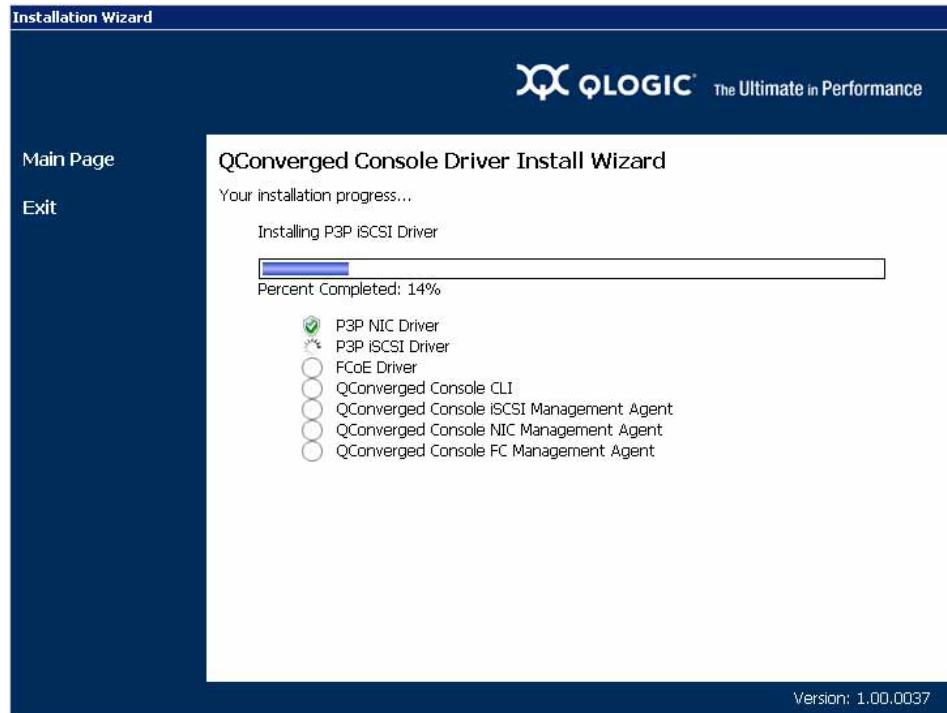

Figure 83 Installation progress

5. After you receive the "Your installation is complete" message, as shown in [Figure 84](#), click **Finish**.

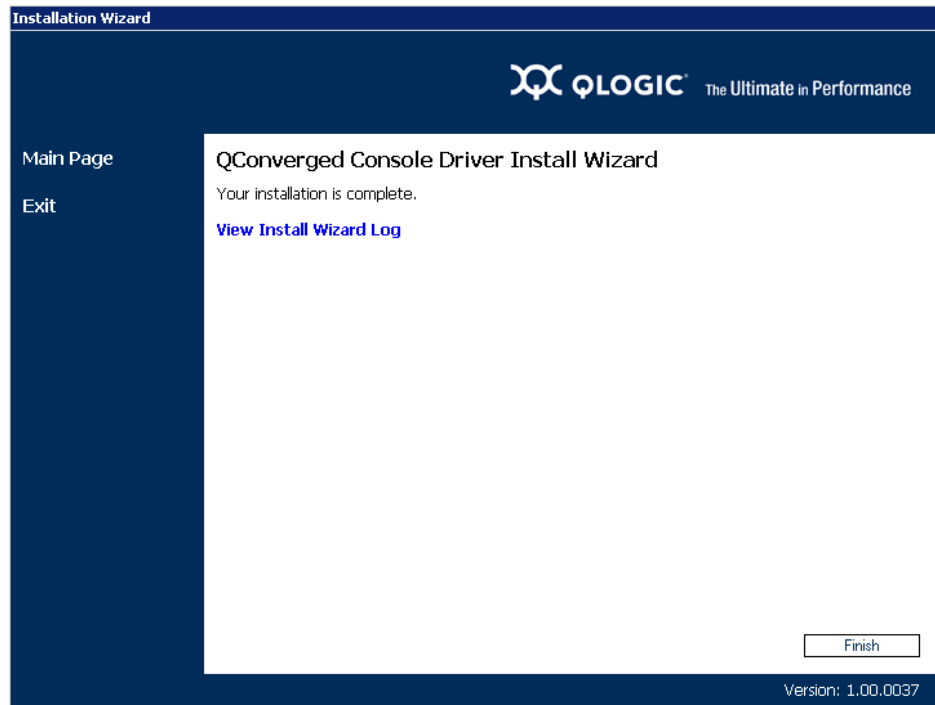

Figure 84 Installation complete

Updating adapter firmware on a QLogic QLE8242 CNA

Before updating adapter firmware, note the following:

- ◆ The QLogic driver must be installed.
- ◆ The QConvergeConsole GUI application must be installed.
- ◆ Before you can perform a firmware update, the firmware file must be downloaded from the QLogic website and extracted to a folder on a local drive. This file could be included on EMC-approved installation media, or downloaded from the QLogic website.
- ◆ If the adapter is already connected to a boot device, the system must be in a state in which this type of maintenance can be.
 - I/O activity on the bus has been stopped.

Installing QConvergeConsole GUI application

- Cluster software, or any other software that relies on the adapter to be available, is stopped or paused.

1. Download the QConvergeConsole installer from the QLogic website in the EMC section and install it on your system. If you have downloaded the kit to your hard drive, locate then double-click, the file.
1. The **QConvergeConsole Installer** window displays, as shown in [Figure 85](#).

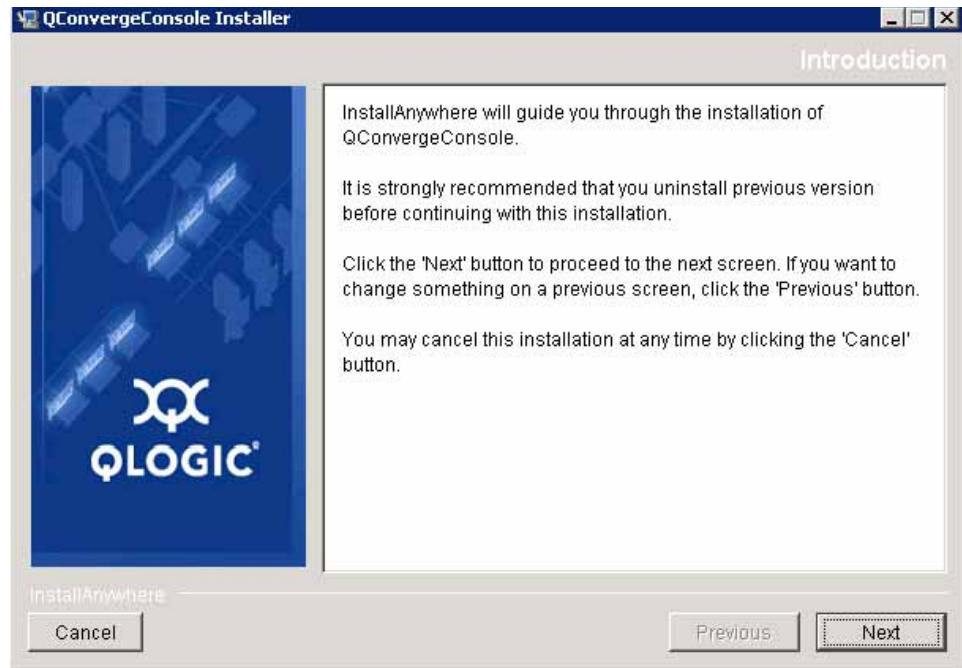

Figure 85 QConvergeConsole Installer Introduction window

2. Click **Next**.

3. The **Tomcat Port Number Setup** window displays, as shown in [Figure 86](#).

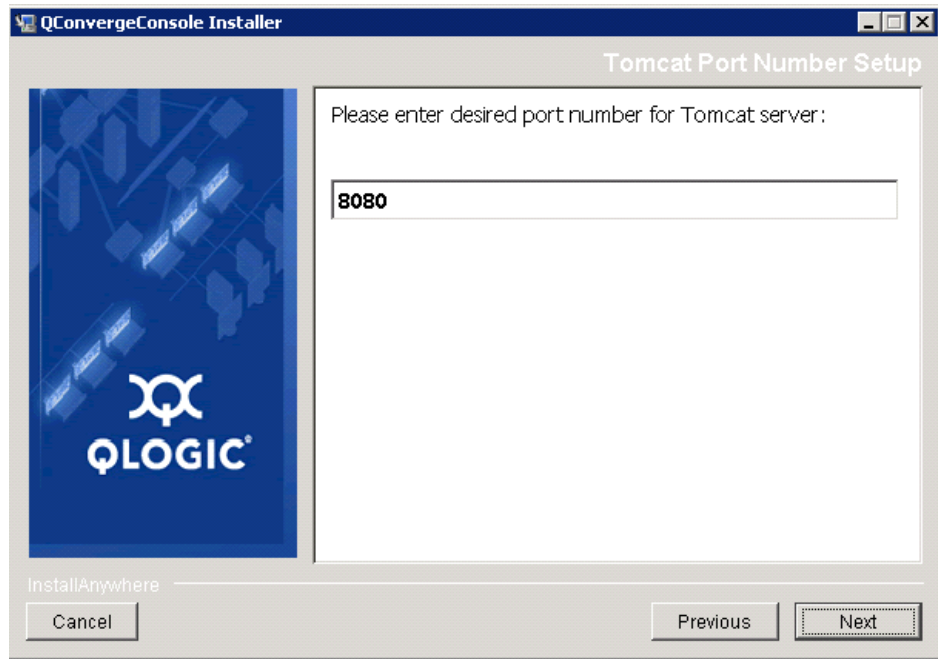

Figure 86 Tomcat Port Number Setup window

4. Accept the default port number and click **Next**.

The **Pre-Installation Summary** window displays, as shown in [Figure 87](#).

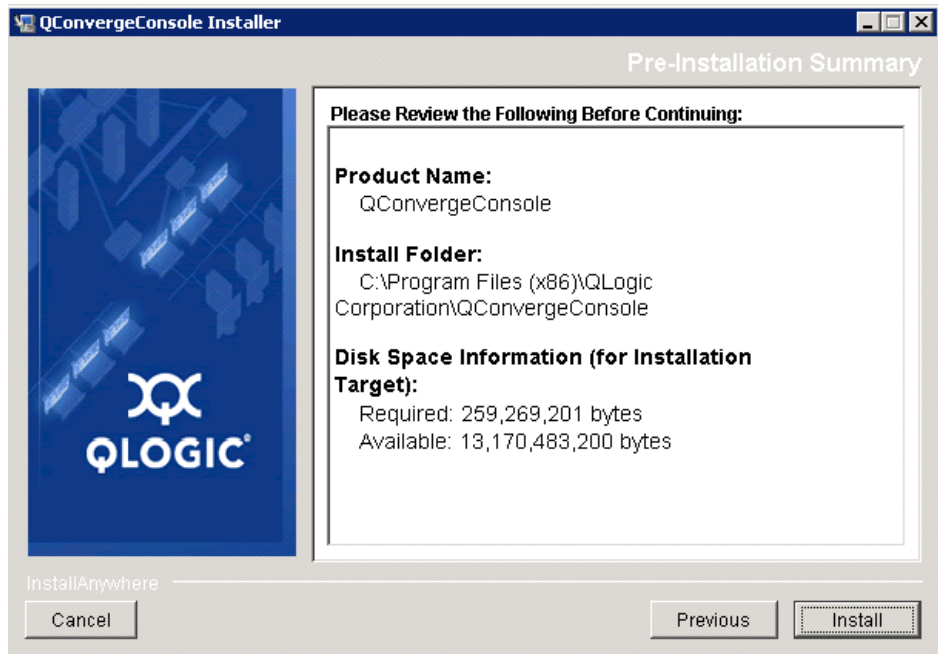

Figure 87 Pre-Installation Summary window

5. Review the summary and click **Install**.

A message asks you whether to enable SSL feature, as shown in [Figure 88](#).

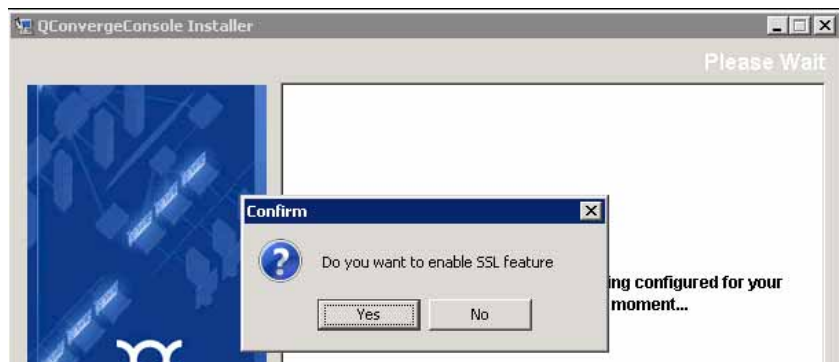

Figure 88 Enable SSL feature dialog box

6. Click **Yes** to enable SSL and the installation starts.
7. When the **Installation Complete** window displays as shown in [Figure 89](#), click **Done** to complete the installation.

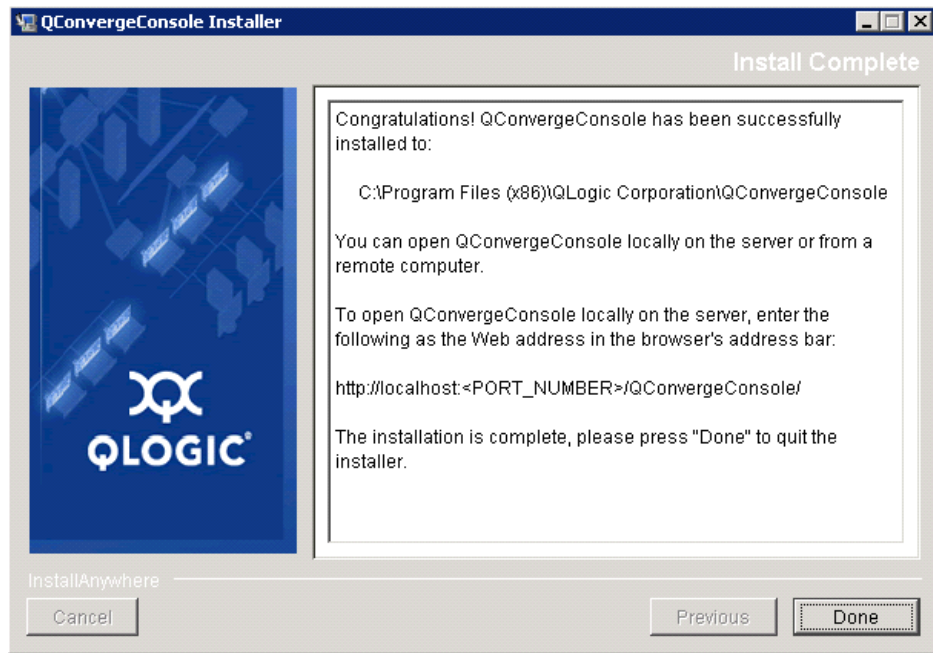

Figure 89 Installation Complete window

Updating firmware To update the Fibre Channel firmware on your FCoE converged network adapter, complete the following steps.

1. Start the QConvergeConsole GUI, as shown in [Figure 90](#).

In the left pane of the utility, you will see the CNA listed under your server name.



Figure 90 QConvergeConsole GUI

- Click on the Port to view the **Port Info** tab, as shown in [Figure 91](#).



Figure 91 Port Info tab

- Click **Wizards** and select **Flash Update Wizard (SAN)** from the drop-down menu, as shown in [Figure 92](#).

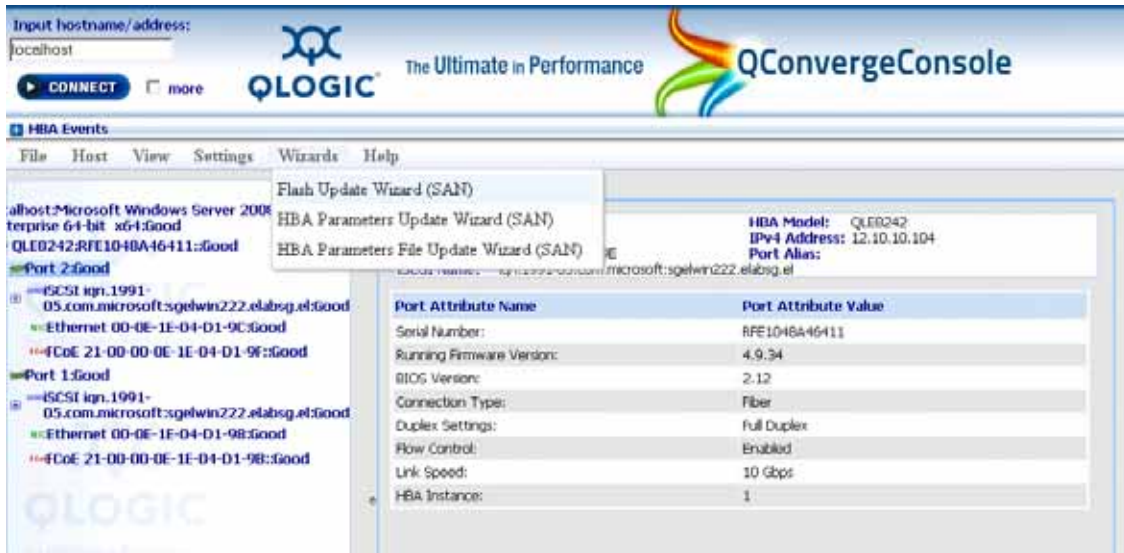

Figure 92 Wizards > Flash Update Wizard (SAN)

This will start the **SAN Flash Update Wizard**, as shown in [Figure 93](#).

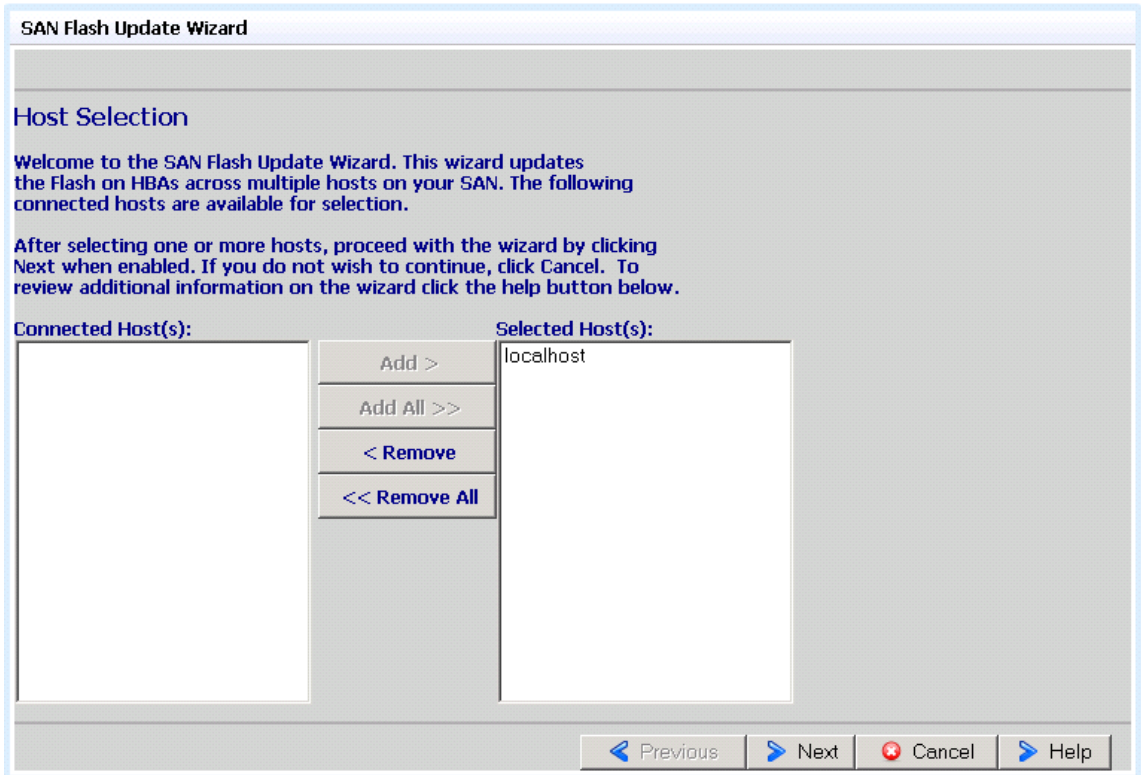

Figure 93 SAN Flash Update Wizard, Add localhost

4. In the **Connected Host(s):** column, select **localhost** and click **Add >** to move it to the **Selected Host(s):** column, as shown in [Figure 93](#).
5. Click **Next**.

6. The **File Selection** window displays, as shown in [Figure 94](#).

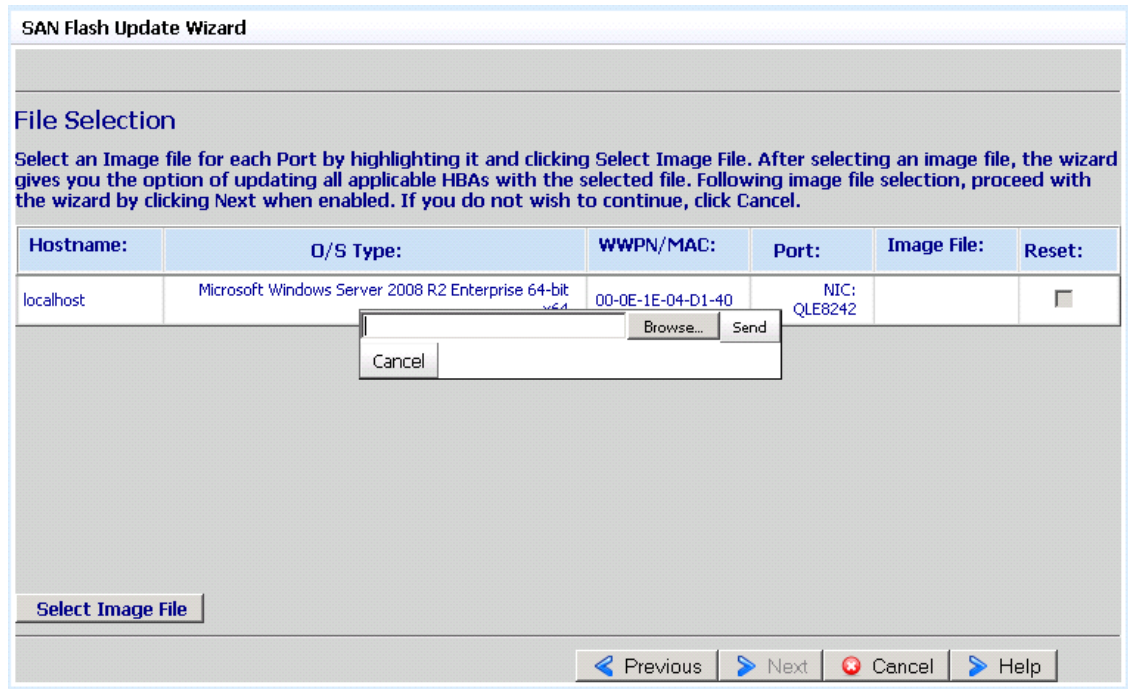

Figure 94 File Selection window

7. Click **Select Image File**.

A pop-up window displays, as shown in [Figure 94](#), that lets you locate and upload the firmware file.

8. After you select the image file, click **Send** on the pop-up window.

The **Confirm Changes** window displays, as shown in [Figure 95](#).

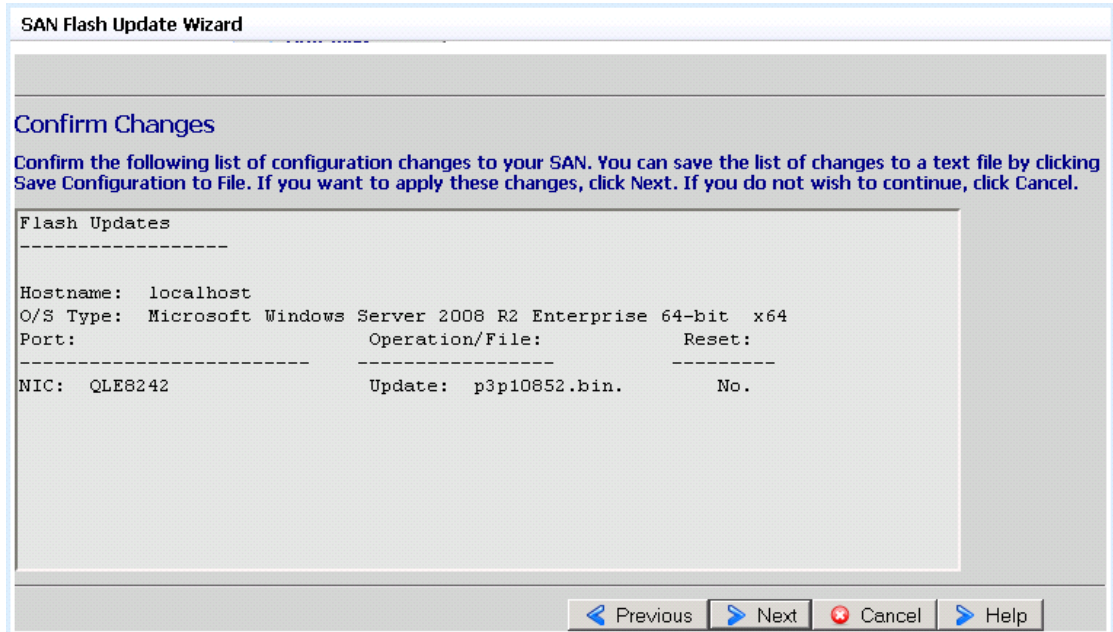

Figure 95 Confirm Changes window

9. Confirm the changes and click **Next**.

A **Security Check** pop-up window displays as shown in [Figure 96](#).

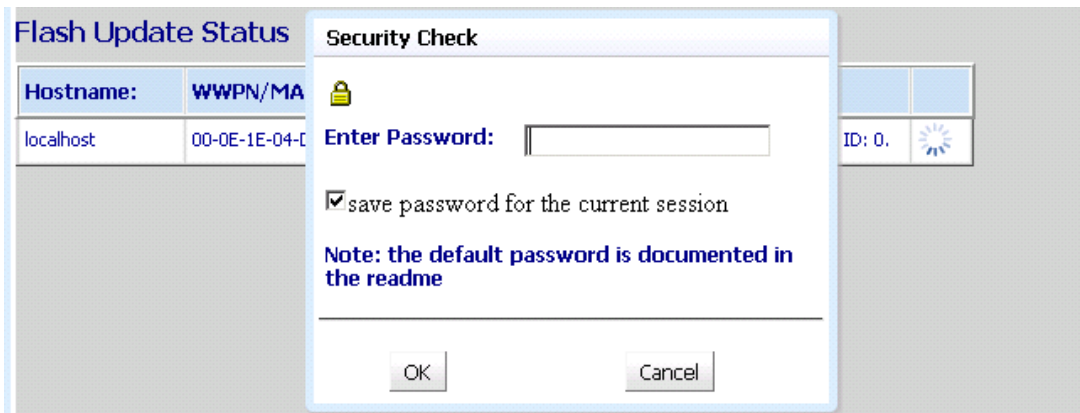

Figure 96 Security Check

10. Type in the password.

The default password is *config* and if you leave the save password for the current session box checked, you will not be required to reenter this password later unless you close QConvergeConsole GUI.

11. Click **OK** to start the flash update.12. When the flash update completes, click **Next**, as shown in [Figure 97](#).

Figure 97 Flash Update Status window

13. When the **Finish** window displays, click **Finish** to complete the flash update, as shown in [Figure 98](#).

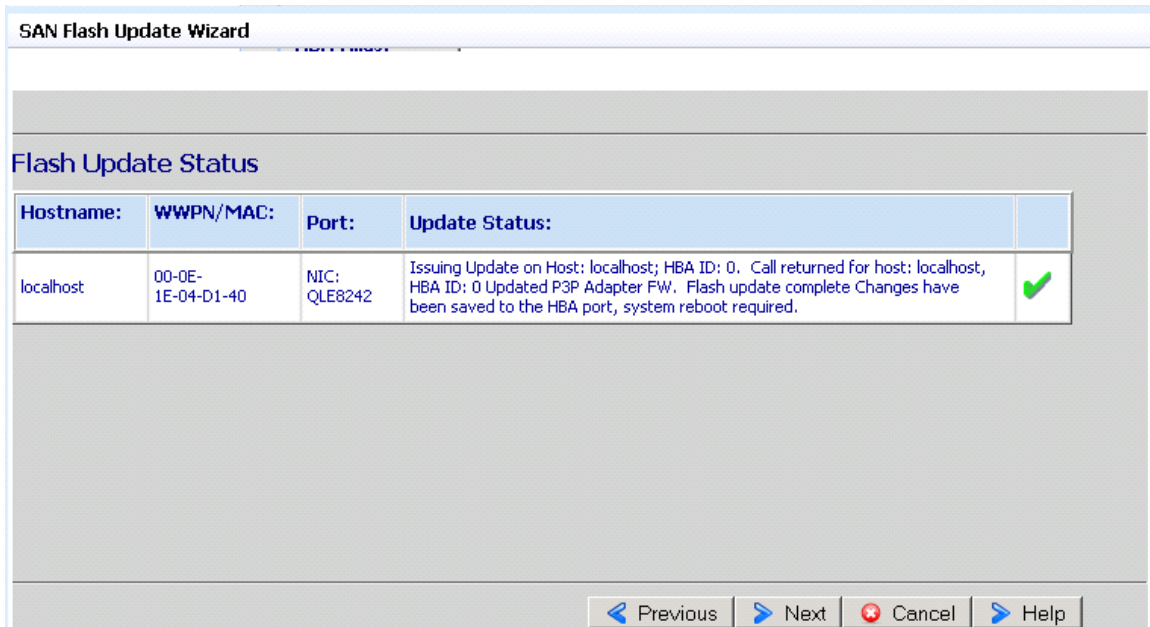
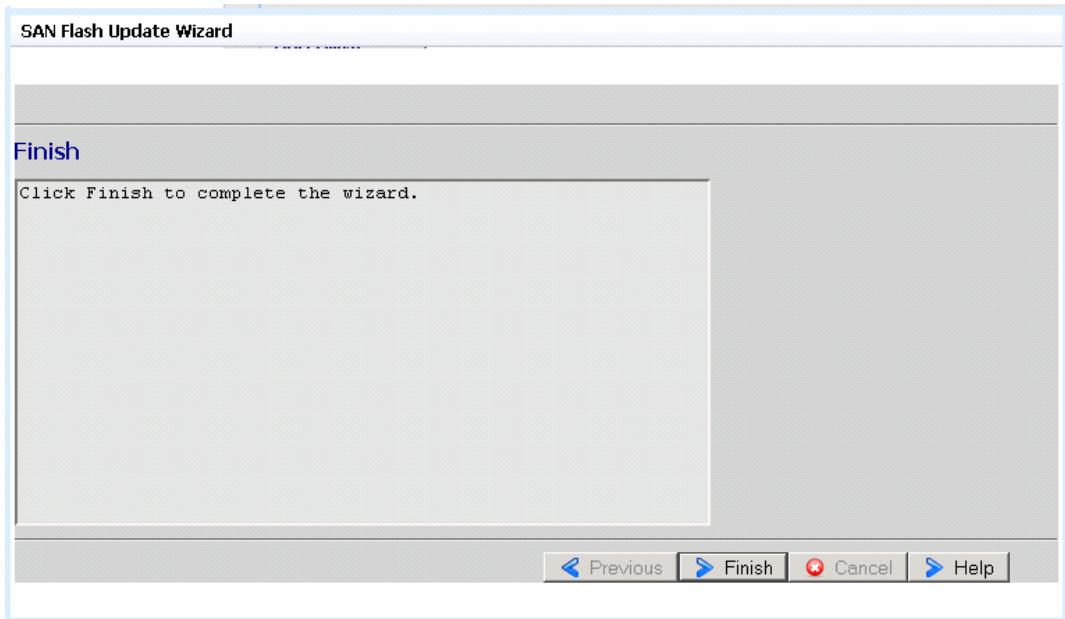

Figure 98 Finish

Configuring QLogic FAST!UTIL 10 GbE iSCSI BIOS/boot LUN settings for QLE8242 iSCSI adapters

This section describes the steps required to configure a QLogic Fast!UTIL 10 GbE iSCSI boot BIOS to allow an array-attached LUN to be used as a boot disk for the server.

To configure QLogic Fast!UTIL 10 GbE iSCSI adapter boot BIOS, complete the following steps.

1. When the QLogic Fast!UTIL 10 GbE iSCSI BIOS banner displays during power-on self-test (POST), as shown in [Figure 99](#), press **Ctrl Q** to enter the **QLogic Fast!UTIL 10 GbE iSCSI BIOS Configuration** utility.

```

QLE8242 iSCSI ROM BIOS Version 2.08
Copyright (C) QLogic Corporation 1993-2011. All rights reserved.
www.qlogic.com

Press <CTRL-Q> for Fast!UTIL
Firmware Version 4.08.20

BIOS for Adapter 1 is disabled

<CTRL-Q> Detected, Initialization in progress, Please wait...
    
```

Figure 99 QLogic Fast!UTIL 10 GbE iSCSI BIOS banner

2. The utility opens to the main **QLogic Fast!UTIL iSCSI Select Utility** page, as shown in [Figure 100](#).

```

QLogic Fast!UTIL
-----
Select Host Adapter
-----
Adapter  Boot Mode  Address  Slot  Bus  Device  Function  MAC Address
-----
QLE8242  Manual    D5800000  03    08    00    4    00-0E-1E-04-D0-62
QLE8242  Disable   D5600000  03    08    00    5    00-0E-1E-04-D0-66
    
```

Use <Arrow keys> to move cursor, <Enter> to select, <Esc> to backup

Figure 100 QLogic Fast!UTIL iSCSI Select Utility page

- Use the arrow keys to select the adapter and the next screen displays selected adaptor configuration options, as shown in Figure 101.

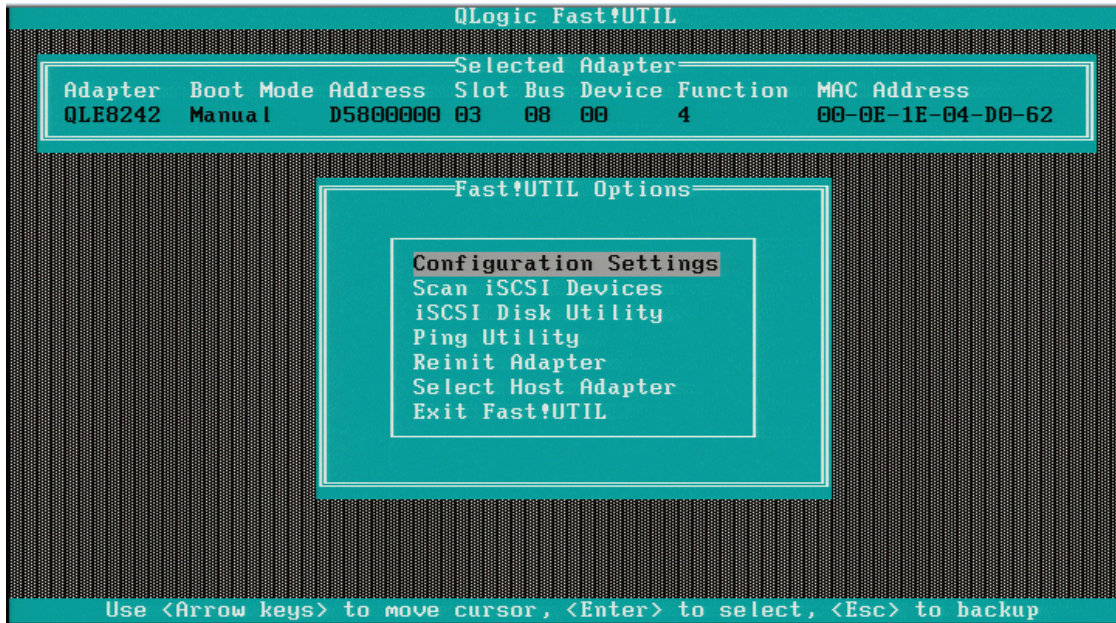

Figure 101 Individual adapter configuration options

- Select **Configuration Settings** and press **Enter**.

The **Configuration Settings** display, as shown in [Figure 102](#).



Figure 102 Configuration setting details

5. Select **Host Adapter Settings** and press **Enter**.

The **Host Adapter Settings** display, as shown in [Figure 103](#).

```

QLLogic Fast!UTIL

-----Selected Adapter-----
Adapter  Boot Mode  Address  Slot  Bus  Device  Function  MAC Address
QLE8242  Manual      D5800000 03    08  00      4          00-0E-1E-04-D0-62

-----Host Adapter Settings-----
BIOS Address :                CA800
BIOS Revision :                2.08
Adapter Serial Number :       RFE1048A46378
Interrupt Level :             4
Initiator IP Settings
Luns per Target :             16
Spinup Delay :                Disabled
Initiator iSCSI Name :       iqn.1991-05.com.microsoft:sgelwi
Initiator CHAP Name :
Initiator CHAP Secret :

Use <Arrow keys> and <Enter> to change settings, <Esc> to exit

```

Figure 103 Host Adapter Settings

6. Select **Initiator IP Settings** and press **Enter**.

7. The **Initiator IP Settings** displays, as shown in [Figure 104](#)

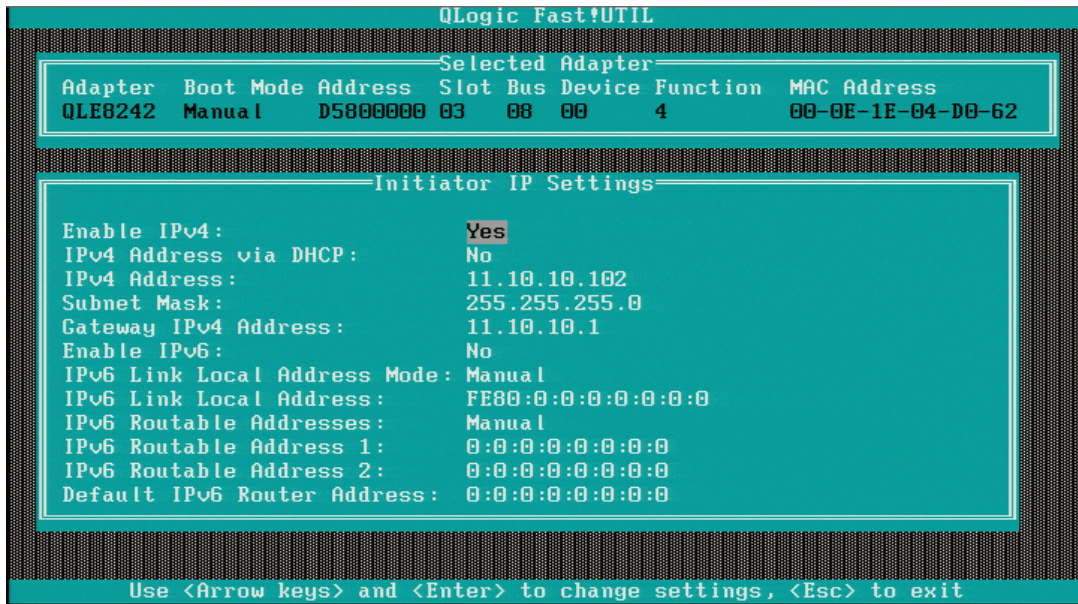

Figure 104 Initiator IP Settings

8. Use the **Arrow** keys and **Enter** key to enable IPv4 and set IP address.
9. Press the **Esc** key to return to the previous **Host Adapter Settings** screen as shown [Figure 103 on page 121](#).
10. Use the **Arrow** keys and **Enter** key to type in the Initiator iSCSI Name, Initiator CHAP Name, and Initiator CHAP Secret, if applicable.
11. Press the **Esc** key to return to previous **Configurations Settings** screen as shown in [Figure 102 on page 120](#).
12. Select **iSCSI Boot Settings** and press **Enter**.

The **iSCSI Boot Settings** displays, as shown in [Figure 105](#).

```

QLogic FastUTIL

-----Selected Adapter-----
Adapter  Boot Mode  Address  Slot  Bus  Device  Function  MAC Address
QLE8242  Manual    D5800000 03    08    00      4         00-0E-1E-04-D0-62

-----iSCSI Boot Settings-----

Boot Device Lun Target IP                               iSCSI Name
Primary:    0   11.10.10.62                               iqn.1992-04.com.emc:cx.c
Alternate:  0

Adapter Boot Mode: Manual
Primary Boot Device Settings
Alternate Boot Device Settings
DHCP Boot Settings

Press "C" to clear selected boot device or <F1>
to display complete iSCSI name of boot device

Use <Arrow keys> and <Enter> to scan devices or change settings, <Esc> to exit

```

Figure 105 iSCSI Boot Settings

13. Select **Primary** and press **Enter**.

The next screen displays the list of targets that are already connected to the host, as shown [Figure 106](#).

```

QLogic Fast!UTIL
-----Select iSCSI Device-----
ID      Vendor  Product          Rev  iSCSI Name
-----
0       DGC      RAID 10         0531 iqn.1992-04.com.emc:cx.cf2a5101
1       No device present
2       DGC      RAID 10         0531 iqn.1992-04.com.emc:cx.cf2a5101
3       No device present
4       EMC      SYMMETRIX       5874 iqn.1992-04.com.emc:50000972084
5       No device present
6       No device present
7       No device present
8       No device present
9       No device present
10      No device present
11      No device present
12      No device present
13      No device present
14      No device present
15      No device present

Use <PageUp/PageDown> keys to display more devices
Press <F1> to display complete iSCSI name of selected device

Use <Arrow keys> to move cursor, <Enter> to select, <Esc> to backup

```

Figure 106 List of targets connected to the host

14. Use the **Arrow** keys and **Enter** key to set the Adapter Boot Mode as Manual.
15. Select **Primary Boot Device Settings** and press **Enter**.

The next page displays the **Primary Boot Device Settings** as shown in [Figure 107](#).

```

QLogic Fast!UTIL

-----Selected Adapter-----
Adapter  Boot Mode Address  Slot Bus Device Function  MAC Address
QLE8242  Manual   D5800000 03  08 00      4      00-0E-1E-04-D0-62

-----Primary Boot Device Settings-----

Security Settings
Use IPv4 or IPv6: IPv4
Target IP:       11.10.10.62
Target Port:     3260
Boot LUN:        0
iSCSI Name:      iqn.1992-04.com.emc:cx.cf2a51017
                  00059.a10

Use <Arrow keys> and <Enter> to change settings, <Esc> to exit

```

Figure 107 Primary Boot Device Settings

16. Use the **Arrow** keys and **Enter** key to enable CHAP and Bidirectional CHAP, and type in CHAP Name and CHAP Secret, if applicable.
17. After you have completed all the setup and boot selections, press the **Esc** key to return to the Individual adapter configuration options screen, as shown in [Figure 101 on page 119](#).
18. Select **Exit Fast!UTIL** and press **Enter**.
19. You will be asked if you want to Reboot System or Return to Fast!UTIL. Press **Reboot System** and the system will reboot.

20. During the subsequent reboot, the QLogic Fast!UTIL 10 GbE iSCSI BIOS banner screen shows the array and LUN that has been specified as a boot-capable LUN, as shown in [Figure 108](#). At this point, the OS installation can begin using this LUN as the boot volume.

```
QLE8242 iSCSI ROM BIOS Version 2.00
Copyright (C) QLogic Corporation 1993-2011. All rights reserved.
www.qlogic.com

Press <CTRL-Q> for Fast!UTIL
Firmware Version 4.00.20

BIOS for Adapter 1 is disabled

<CTRL-Q> Detected, Initialization in progress, Please wait...

Device Device Adapter Target Lun Vendor Product Product
Number Type Number ID Number ID ID Revision
Disk 0 0000 0 DGC RAID 10 0531
ROM BIOS Installed
```

Figure 108 QLogic Fast!UTIL 10 GbE iSCSI BIOS banner

Establishing connectivity to the storage array

Once the adapter has been properly configured, connectivity will need to be established between the adapter and the storage array. In the case, where the adapter will be directly connected to the storage array, the cable can just be attached. However, when attaching to an FC or FCoE switch, several additional configuration steps are needed. These include zoning the port on the adapter to the correct port on the storage array, as well as configuring LUN Masking on the array. For additional information on how to perform these additional installation steps, refer to the *EMC Networked Storage Topology Guide*, located at: <http://elabnavigator.EMC.com>.

Verifying connectivity to the storage array

You can verify connectivity either with

- ◆ QLogic SANSurfer, discussed next, or
- ◆ Server Manager, [page 130](#)

Verifying connectivity through QLogic SANSurfer

To verify connectivity through QLogic SANSurfer:

On a Windows Server start the SANsurfer application, which includes the SANsurfer FC HBA Manager GUI. When complete, the SANsurfer application GUI displays. (Refer to the **SANsurfer FC HBA Manager** main window, as shown in [Figure 111 on page 130](#)).

1. Double-click the SANsurfer icon, as shown in [Figure 109](#), on your desktop (if the icon was created during installation).



Figure 109 SANsurfer icon

2. Click **Connect** on the **SANsurfer FC HBA Manager** main window toolbar.
3. On the **SANsurfer FC HBA Manager** main window **Host** menu, click **Connect**.
4. Right-click the **HBA tree**. From the shortcut menu, click **Connect**.
5. Press **HOME**.

The **Connect to Host** dialog box displays, as shown in [Figure 110 on page 129](#).

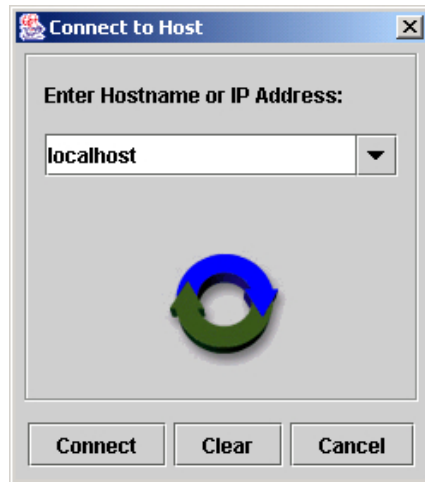

Figure 110 Connect to the host

6. In the **Enter Hostname or IP Address** field, perform one of the following:
 - Select localhost to connect to the machine on which you are using the SANsurfer FC HBA Manager GUI.
or
 - Type or select a remote machine. You can use the hostname or the machine's IP address.
7. Do one of the following:
 - Click **Connect** to initiate the connection. If successful, the host and its HBAs display in the HBA tree. If you entered a new remote host and the connection was successful, its name is also added to the **Enter hostname or IP address** box drop-down list.
 - Click **Cancel** to abort the connection process and return to the **SANsurfer FC HBA Manager** main window, as shown in [Figure 111 on page 130](#).
 - Click **Clear** to delete all machines on the list except local host. (The local machine cannot be deleted.)

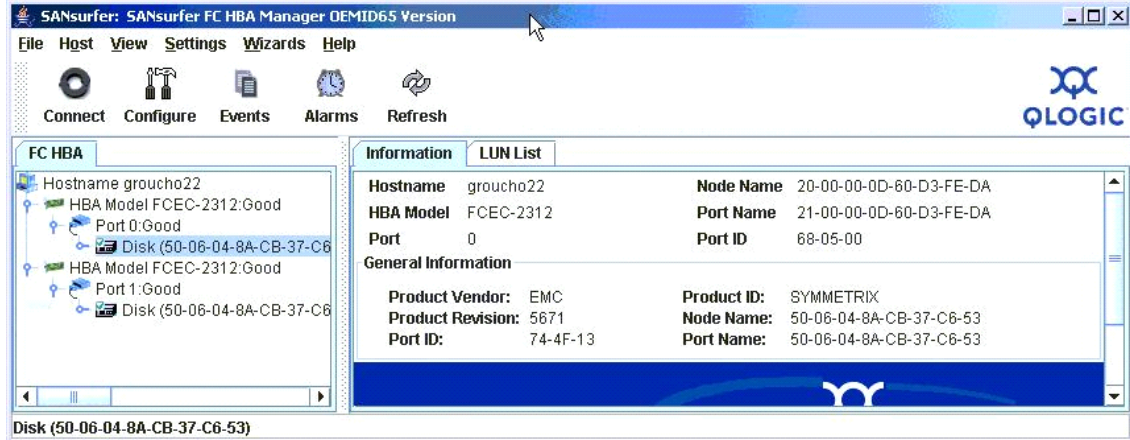

Figure 111 SANsurfer, SANsurfer FC HBA manager

Verifying connectivity using the Server Manager

To verify an adapter is connected to a storage device using ServerManager:

Note: The display assumes the driver and cable were properly installed. For more detail, refer to [“Installing adapter driver and software utilities”](#) on [page 76](#).

1. Right-click **My Computer** on the desktop and select **Manage** to display the **Server Manager** dialog box (Figure 112).



Figure 112 Server Manager window: Storage controllers pane

2. Select **Diagnostics > Device Manager** and click on **Storage controllers** icon (Figure 112) to verify that adapters are detected and installed.

3. Click **Disk Drives** to list all target LUNS attached to the entire system (Figure 113).

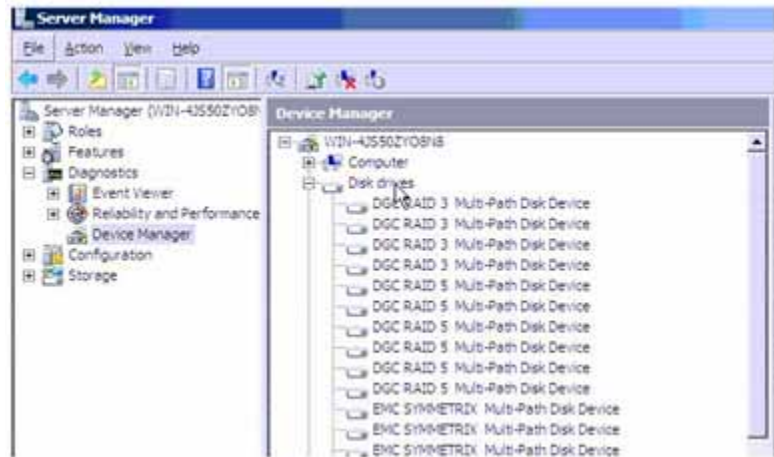

Figure 113 Server Manager window: Disk drives pane

Installing additional Unisphere/Navisphere Host Agent software

The Unisphere/Navisphere Host Agent should be used to automatically register host connections with the array. PowerPath® and ATF require different registration types and the Unisphere/Navisphere Host Agent is the preferred method over manual registrations.

You should install the Unisphere/Navisphere Host Agent software to ensure the adapter connections are all registered correctly. For instructions on how to perform this operation refer to the EMC ControlCenter® Unisphere/Navisphere Host Agent software documentation for your array type.

After the host agent has started and registered the new adapter paths, you should refresh the host connections in the storage group to ensure all available paths are assigned. To do this, you have two options, depending on whether you want to disrupt the connectivity of the host, as described next.

Option 1: Without disrupting host connectivity (more complex procedure using Navisphere CLI):

Note: You must have Navisphere CLI installed. Refer to product notes for complete usage instructions.

1. Using a command prompt, browse to the Navisphere CLI directory (typically C:\Program Files\EMC\Navisphere CLI).
2. Enter command **navicli -h <sp_IP> storagegroup -connecthost -host <hostname> -gname <storagegroupname>**

where <sp_IP> is the IP address of either array SP; <hostname> is the hostname of the host connection to update and <storagegroupname> is the name of the storage group of the host connection to update.

3. When prompted, verify the <hostname> and <storagegroupname> are correct as follows:

```
Connect host <hostname> to storage group
<storagegroupname> (y/n)?"
```

Enter **y** to proceed.

4. Perform a device rescan on your host, and verify the additional device paths are present.

Option 2: With brief disruption of host connectivity (simpler procedure using Unisphere/Navisphere GUI):

1. Shut down the host.
2. Remove the host from the storage group.
3. Apply the change.
4. Add the host back into the storage group.
5. Restart the host.
6. Check the array connectivity status to ensure all connections you require are active.

This chapter contains information on miscellaneous procedures.

- ◆ Zoning and connection planning in a fabric environment 136
- ◆ Installing and configuring the QLogic QLA40xx and QLe40xx iSCSI adapter (TOE) 137
- ◆ Booting from SAN with QLogic QLA40xx and Microsoft Initiator 146
- ◆ Boot-from-SAN configuration restrictions 156
- ◆ Setting up external boot for IBM BladeCenter server HS40 (8839) 157
- ◆ Manually installing the adapter driver – Advanced users 159
- ◆ QLogic advanced utilities 167
- ◆ Procedure for replacing a QLogic adapter in Stratus ftServers without rebooting 171
- ◆ Special instructions for the EMC CLARiiON CX200 series 174
- ◆ QLogic NPIV solution 178

Zoning and connection planning in a fabric environment

In a fabric environment, the user should plan for the switch topology, target-to-hosts mapping, and the zone. Here is an overview of the recommended procedure:

1. Draw the connectivity among the hosts, switch, and storage array to verify the correct fabric configuration.
2. Configure the zone capability in the switch. If connecting to EMC Connectrix™, refer to the *Connectrix v7.01 Enterprise Storage Network System Planning Guide* for information on the zone configuration.

Installing and configuring the QLogic QLA40xx and QLe40xx iSCSI adapter (TOE)

The QLA40xx and QLe40xx are iSCSI adapters that provides PCI connectivity to SCSI using the iSCSI protocol. iSCSI enables IP-based SANs, which are similar to Fibre Channel SANs. The QLA4010/4010C adapters implement TCP/IP protocol on the adapter and relieves the host of any I/O protocol processing. This type of adapter also is called a TCP/IP Offload Engine (TOE) adapter. Off-loading frees the system to perform other tasks and optimizes system performance.

Installation of the QLA/e40xx iSCSI adapter is similar to installation of other QLogic adapters. Refer to the sections for “[Installing the adapter](#)” on page 18 and “[Manually installing the adapter driver – Advanced users](#)” on page 159 for configurations that are booting from the EMC storage array.

Using the QLogic iSCSI SANsurfer application to configure iSCSI devices

QLogic provides a minimal version of their SANsurfer software used to configure settings for the QLA40xx and QLe40xx iSCSI adapters. Install the SANsurfer iSCSI HBA Manager on your server using the self-extracting executable installation package (available in the EMC QLA4010 CD-ROM kit or from the QLogic website (<http://www.qlogic.com>)). During installation, you may choose whether to install both the GUI and agent or just the GUI. If you are installing on the system with the QLA40xx adapter(s) installed, install both the GUI and agent.

After SANsurfer is installed, it can be started from the **Start** menu, or from the desktop icon if you choose to create one.

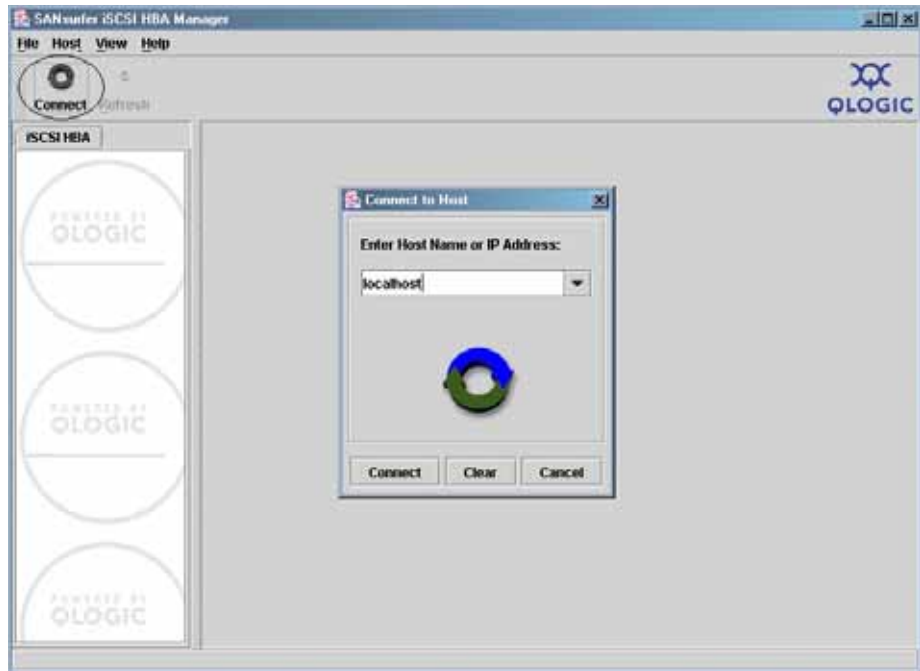

Figure 114 SANsurfer iSCSI HBA Manager, connect to host

- ◆ Click **Connect** in the upper left corner of the **SANsurfer iSCSI HBA Manager** dialog to get the **Connect to Host** dialog, as shown in [Figure 114](#).

You are asked which host to connect to. Assuming you are running the software on the server with the adapter(s) installed, keep the default name of **localhost** as the hostname and then click **Connect**.

- ◆ On the **SANsurfer iSCSI HBA Manager** dialog, the left pane displays discovered iSCSI HBAs. Click on the desired HBA in order to change its settings.

The **SANsurfer iSCSI HBA Manager** dialog defaults to the **HBA Options** tab, which is selected from the row of tabs at the top, as shown in [Figure 115 on page 139](#).

- ◆ From the **HBA Options**, you can set the iSCSI HBA parameters including IP address, subnet mask, and gateway. If an iSNS server is being used for your iSCSI configuration follow the procedure for setting up iSNS later in “Configuring iSNS settings for QLA4010” on page 140.

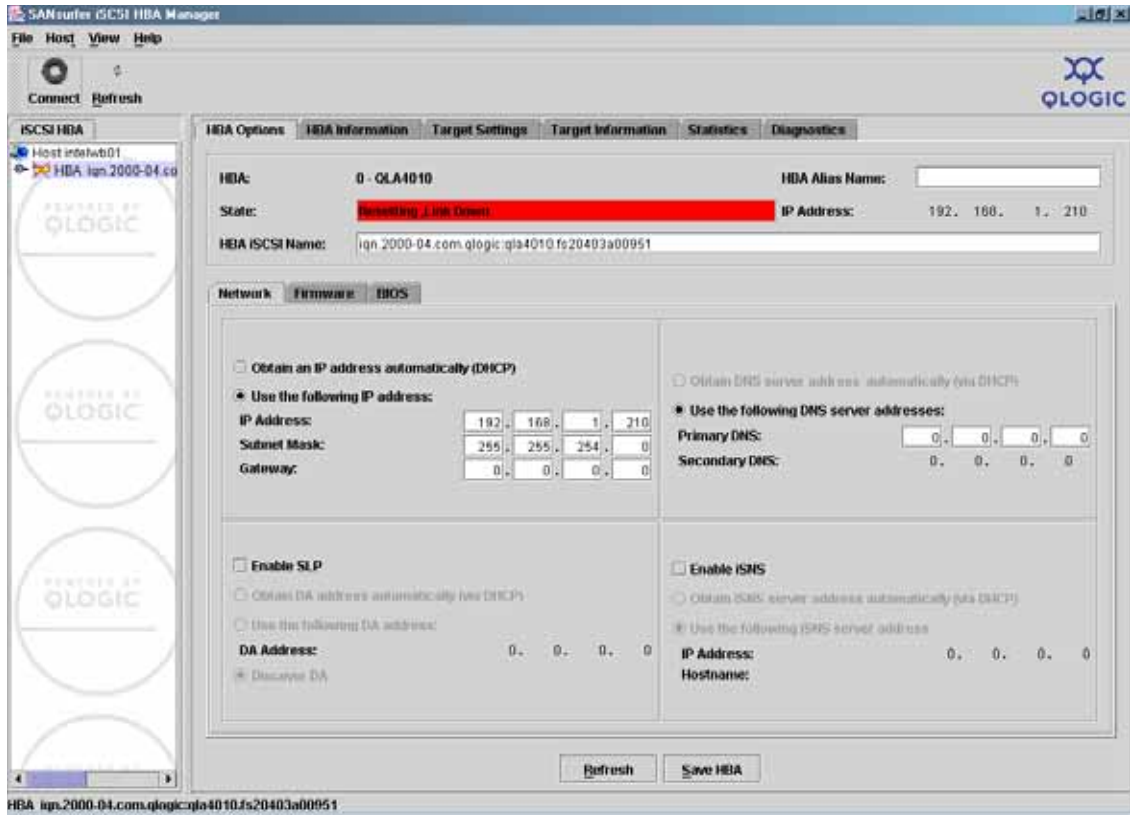

Figure 115 SANsurfer iSCSI HBA Manager, HBA Options

Important notes

For Microsoft support on Windows 2003 operating systems, it is required that the latest version of Microsoft Initiator SERVICE be installed. Installing the entire Initiator package may cause a conflict with the QLogic iSCSI HBA functionality. After installing the Initiator service, it will change the QLogic iqn to the Microsoft iqn naming convention (for example, iqn.1991-05.com.microsoft:username.domainname).

To confirm the name has changed, go to the Qlogic SANSurfer utility. If the name has not changed automatically, it can be done manually. To manually change the iqn:

1. Go to **Device Manager > SCSI and RAID controllers > QLogic iSCSI Adapter**.

The **QLogic iSCSI Adapter Properties** dialog box displays.

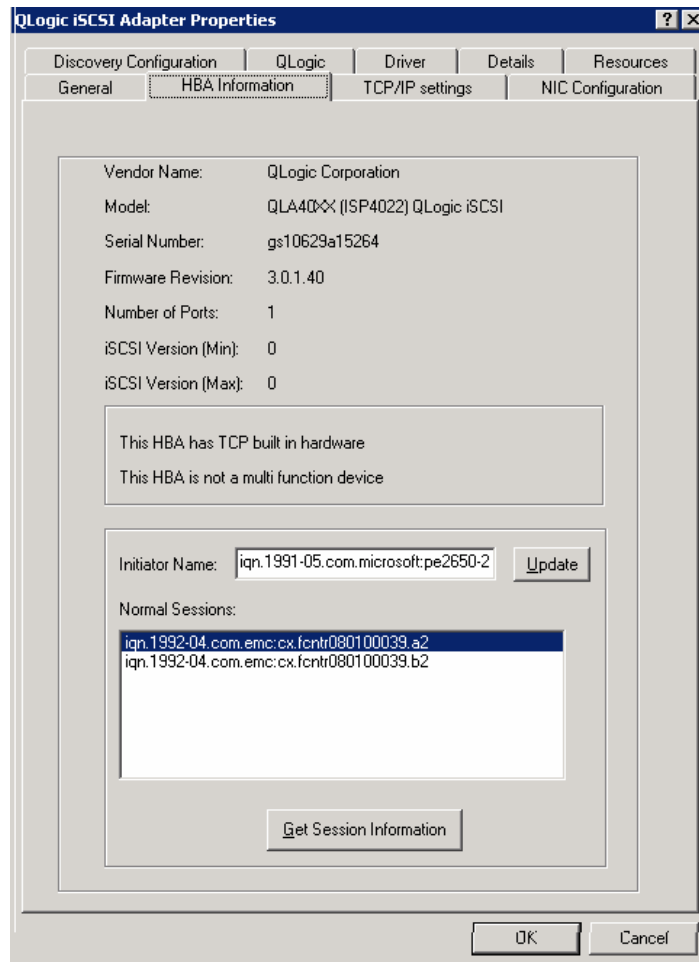

2. Right-click on the **HBA Information** tab.
3. Press **Update**.

Configuring iSNS settings for QLA4010

For iSNS support, the QLA4010 must be running the correct driver. Refer to the for latest version.

Targets must register with the iSNS server. To register, enable the iSNS server and enter the IP address using the **SANsurfer iSCSI HBA Manager, HBA Options, Network, Enable iSNS** dialog box. Click **Save HBA** under the **Network** tab on the **SANsurfer iSCSI HBA Manager, HBA Options** tab.

The target should be detected by SANsurfer and shown on the **SANsurfer iSCSI HBA Manager, Target Settings** tab. Click **Save Settings** to bind the targets.

If the targets are not detected, follow these steps:

1. Ping successfully to the iSNS server using the **Diagnostics** tab from the **SANsurfer iSCSI HBA Manager** dialog.
2. Go to iSNS server and iSNS server icon in the control panel or desktop.
3. Open **Discovery Domain** and confirm that both the QLA4010 and target ports are registered with the domain.

To update firmware on your iSCSI adapter:

1. Click the **Firmware** tab on the **HBA Options** dialog, as shown in [Figure 116](#).

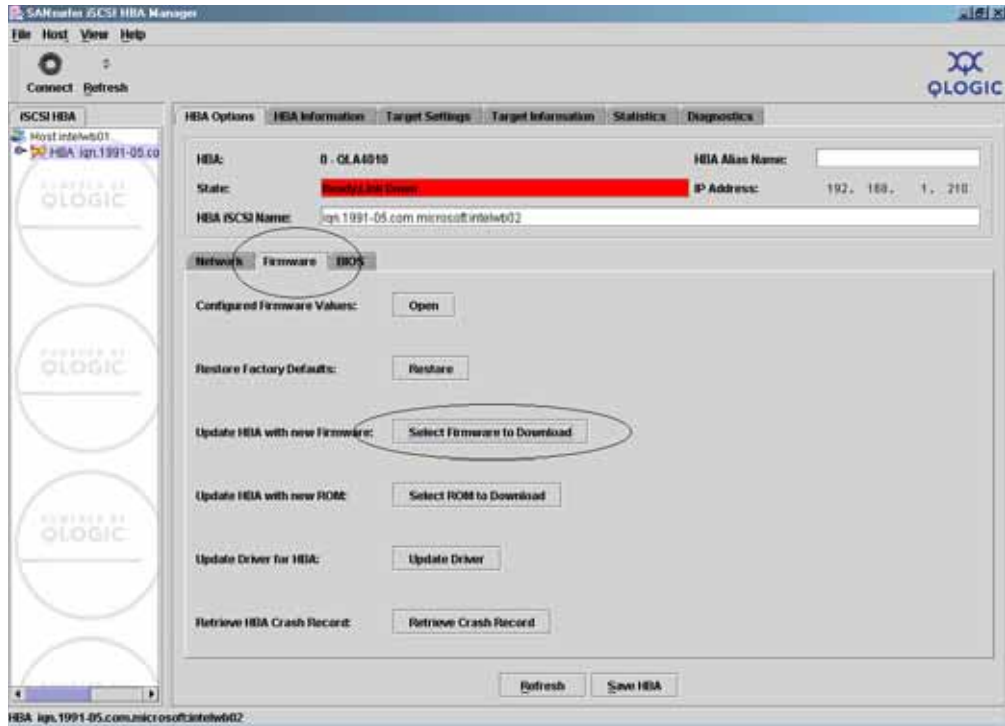

Figure 116 SANsurfer iSCSI HBA Manager, HBA Options, Firmware tab

2. Click **Select Firmware to Download**.
3. In the dialog that appears, as shown in [Figure 117](#), type in the path to the firmware file that you want to load to the adapter, and click **Save**.

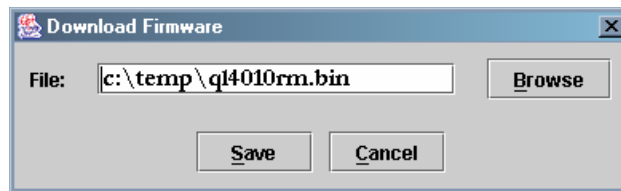

Figure 117 Download Firmware dialog box

The firmware will be loaded to the specified adapter. After it loads,

SANsurfer will reset the adapter so the new firmware will take effect.

- ◆ Boot BIOS for the iSCSI adapter can be loaded in a similar fashion. From the **SANsurfer iSCSI HBA Manager**, **HBA Option** dialog, click the **BIOS** tab, as shown in [Figure 118](#).

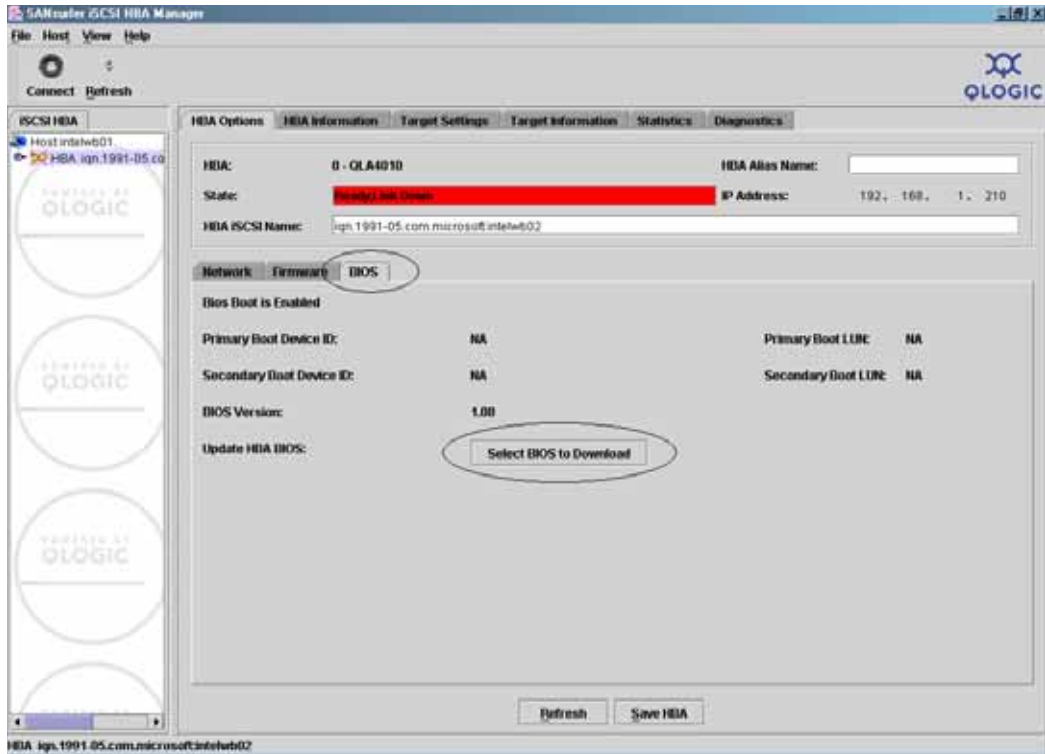

Figure 118 SANsurfer iSCSI HBA Manager, HBA Options, BIOS tab

- ◆ To configure your iSCSI targets, click the **Target Settings** tab from the **SANsurfer iSCSI HBA Manager** dialog, as shown in [Figure 119](#).

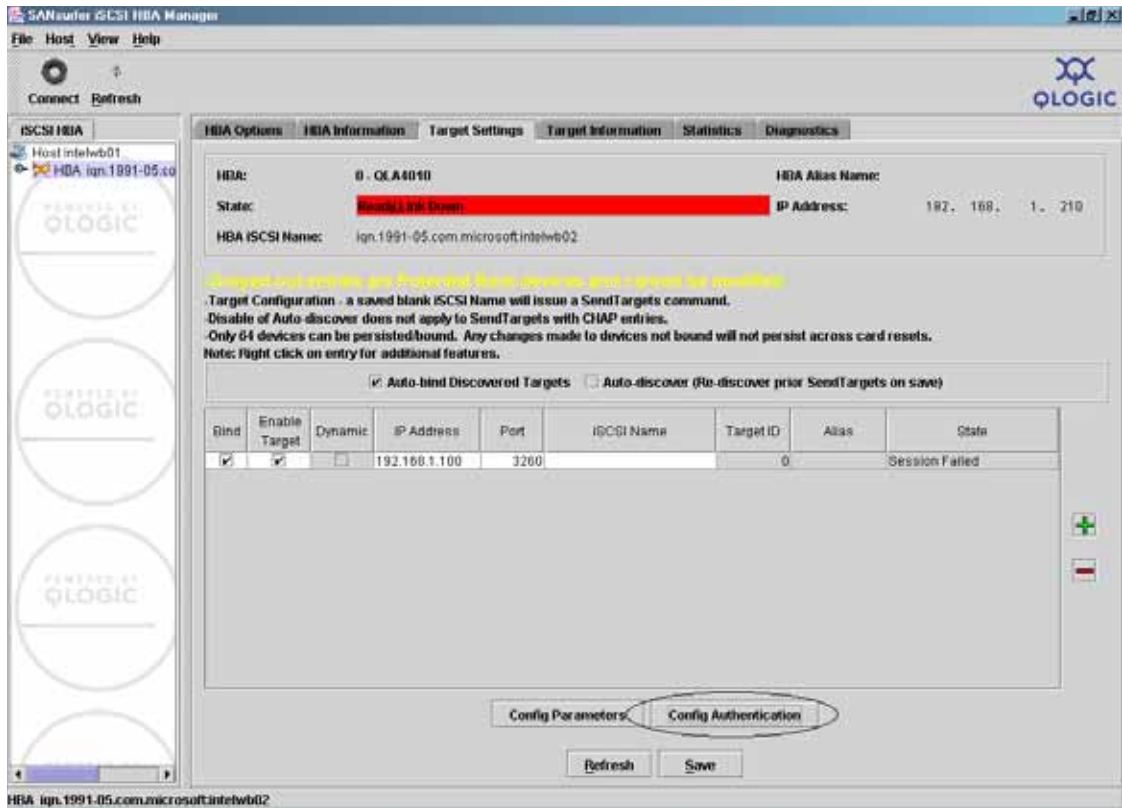

Figure 119 SANsurfer iSCSI HBA Manager, Target Settings tab

- ◆ To add your target, click the green + on the right side of the **Target Settings** tab to get the **IP Address** dialog, as shown in [Figure 120](#). Enter the IP address of your target port, and click **OK**.

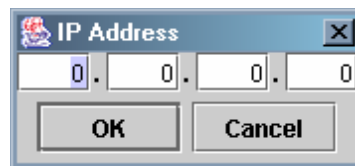

Figure 120 SANsurfer iSCSI HBA Manager, Target Settings, IP Address dialog

- You can add as many targets as needed. If you need to enter CHAP security for any target, click **Config Authentication** at the bottom of the dialog, as shown in [Figure 119 on page 143](#), to get the **Authentication Configuration** dialog, shown in [Figure 121](#).



Figure 121 Authentication Configuration, CHAP tab

- ◆ On the **Authentication Configuration, CHAP** tab, you can:
 - Set a default name and secret for all targets; or
 - Click the individual target and enter an unique name and secret settings for that target.

Note: Initiator CHAP settings do not get masked and could be compromised if an unauthorized user accesses the SANsurfer workstation.

- ◆ After CHAP settings are made, click **OK** at the bottom of the **Authentication Configuration** dialog, as shown in [Figure 121 on page 144](#).
- ◆ To save all target settings, click **Save** at the bottom of the **SANsurfer iSCSI HBA Manager, Target Settings** tab, as shown in [Figure 119 on page 143](#). You will be prompted for the SANsurfer security password. The default password is **config**, but it can be changed.
- ◆ After the settings are saved, SANsurfer resets the adapter, and if target information was discovered properly, you will see active connections listed on the **SANsurfer iSCSI HBA Manager, Target Information** tab. You can also view active targets under the adapter in the left pane as shown in [Figure 122](#).

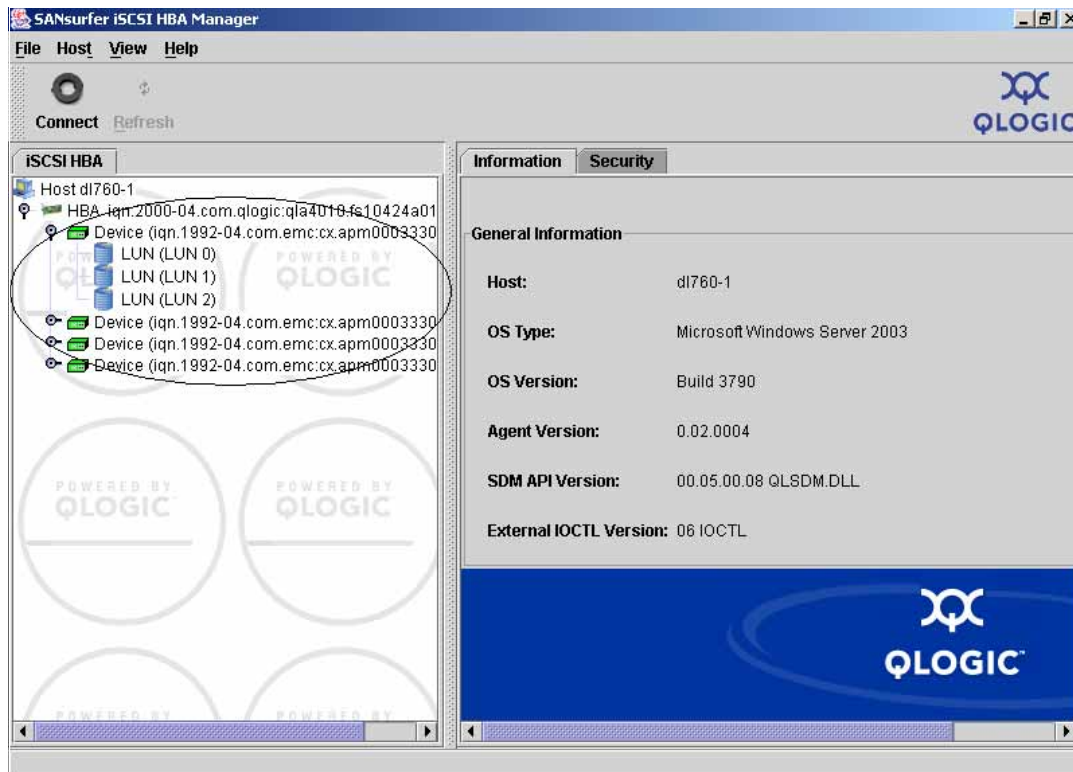

Figure 122 SANsurfer iSCSI HBA Manager, Information tab

SANsurfer has other features that are useful in managing your iSCSI storage configuration. Please refer to the QLogic SANsurfer documentation for more information about these additional features.

Booting from SAN with QLogic QLA40xx and Microsoft Initiator

The following procedure for booting from SAN with a QLogic iSCSI adapter with Microsoft Initiator Service is illustrated using a VNX series or CLARiiON CX series storage system. Booting with a QLogic iSCSI adapter with Microsoft Initiator Service can also be done on a Symmetrix storage array. For more information, refer to Symmetrix LUN Masking documentation.

The important concept is understanding the adapter's iqn name, its relationship to persistent binding in a SAN environment, and how the Microsoft Initiator Service changes the iqn name.

IMPORTANT

Failing to change the iqn name before installing the Windows operating system will cause the host to blue screen for an inaccessible boot device when the Microsoft Initiator Service changes the iqn name after being installed.

Note: Booting from SAN with QLA40xx and Microsoft Initiator follows the same setup configuration as boot from SAN with the QLogic QLA40xx iSCSI adapter.

IMPORTANT

At this point, only connect the adapter that will be used to boot. Remaining adapter(s) can be connected after the Windows operating system is installed. Failing to do so could result in a blue screen during the installation process. Best practice recommends having only the LUN you will be booting from presented to the host. This will ease the process of selecting the correct boot LUN during the adapter configuration and during the O/S installation. Remaining LUNS can be added after the installation.

1. The first step is to know what you are going to name your server and how that translates into an iqn name. Microsoft Initiator uses the following naming convention: `iqn.1991-05.com.microsoft : servername.domainname`. Therefore, if the server name is to be *test*, and the domain name is *workgroup*, then the name the Initiator will use to rename the adapter will be `iqn.1991-05.com.microsoft:test.workgroup`.

2. On the host, go into the QLogic BIOS and change the iqn name to `iqn.1991-05.com.microsoft:servername`. (If networking is configured during installation, set the iqn name to `iqn.1991-05.com.microsoft :servername.domainname`).

This can be accomplished by the following procedure:

- a. On **POST** when the QLogic adapter displays, press **< Ctrl Q >** for **Fast!Util**.

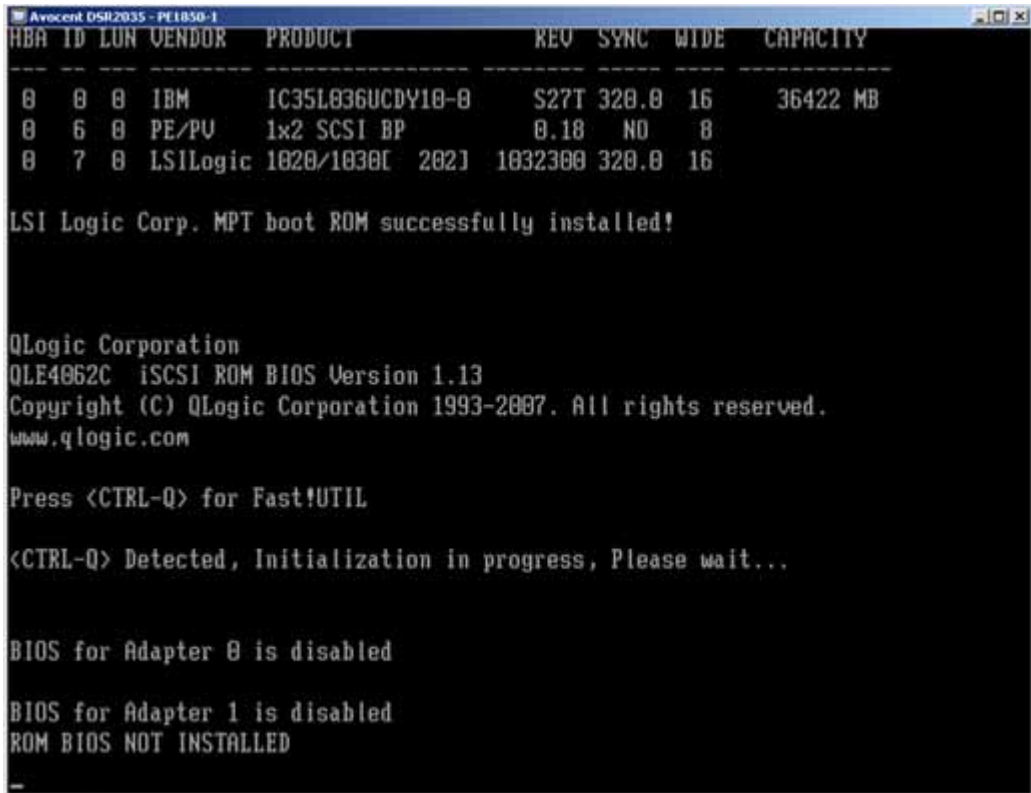

```
Avocent DS12035 - PE1850-1
HBA ID LUN VENDOR PRODUCT REV SYNC WIDE CAPACITY
-----
0 0 0 IBM IC35L036UCDY10-0 S27T 320.0 16 36422 MB
0 6 0 PE/PU 1x2 SCSI BP 0.18 NO 8
0 7 0 LSILogic 1020/1030[ 202] 1032300 320.0 16

LSI Logic Corp. MPT boot ROM successfully installed!

QLogic Corporation
QLE4062C iSCSI ROM BIOS Version 1.13
Copyright (C) QLogic Corporation 1993-2007. All rights reserved.
www.qlogic.com

Press <CTRL-Q> for Fast!UTIL

<CTRL-Q> Detected, Initialization in progress, Please wait...

BIOS for Adapter 0 is disabled

BIOS for Adapter 1 is disabled
ROM BIOS NOT INSTALLED
```

b. Select the Host Adapter that you are working with.

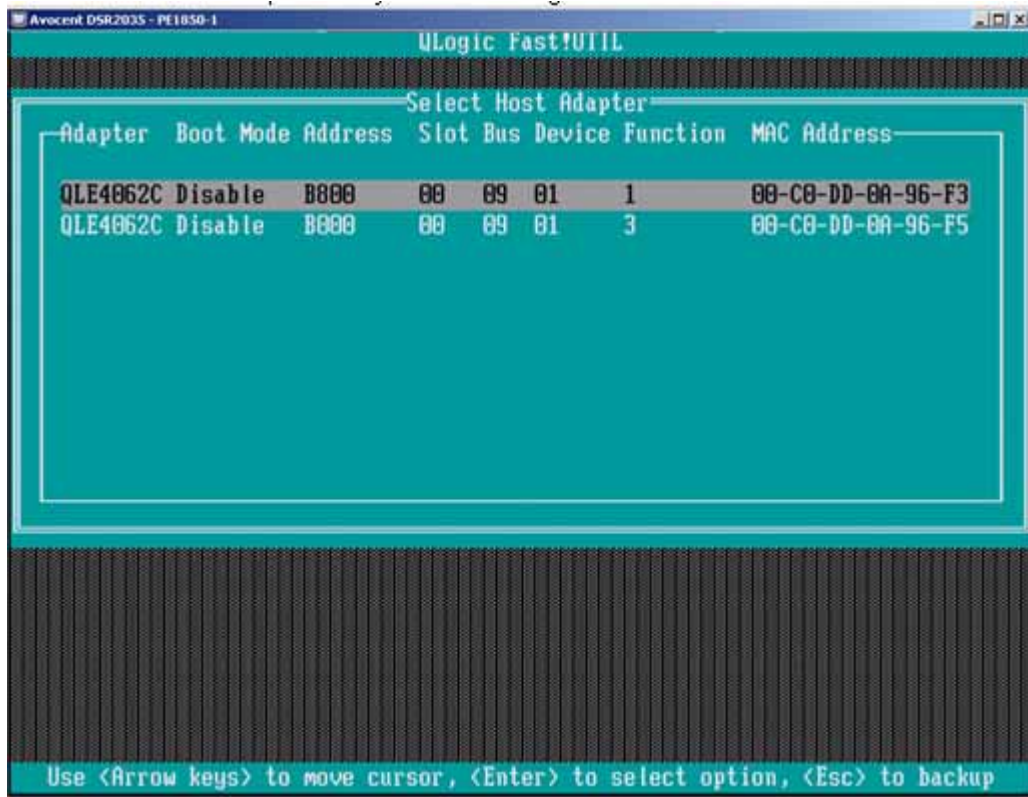

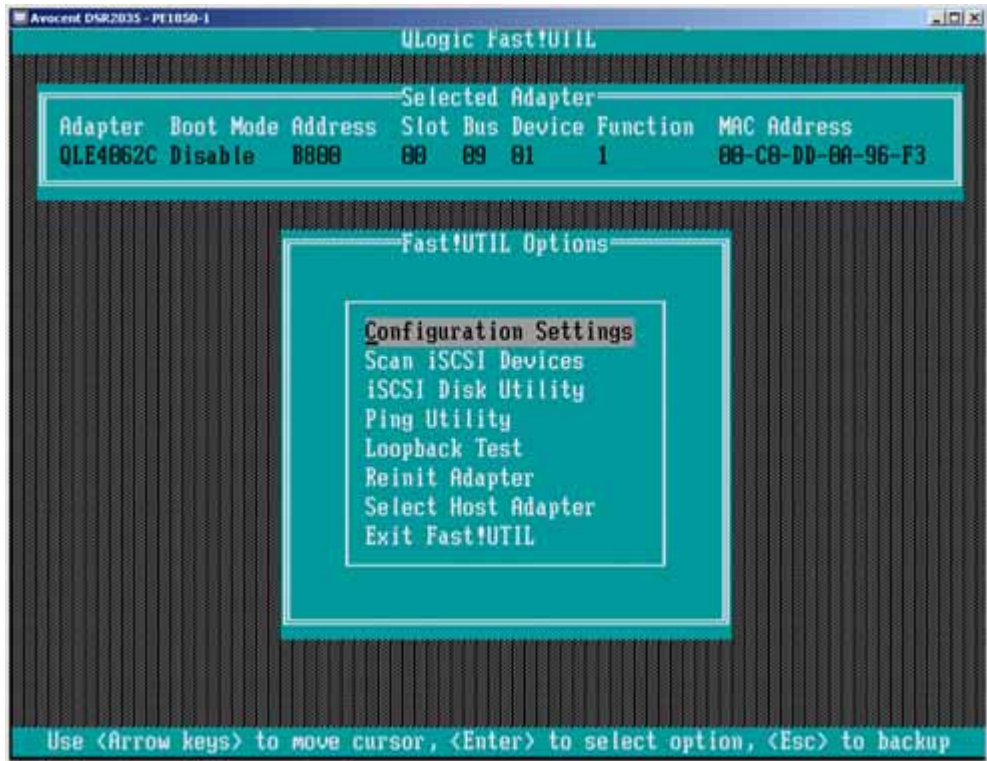
c. Select **Configuration Settings**.

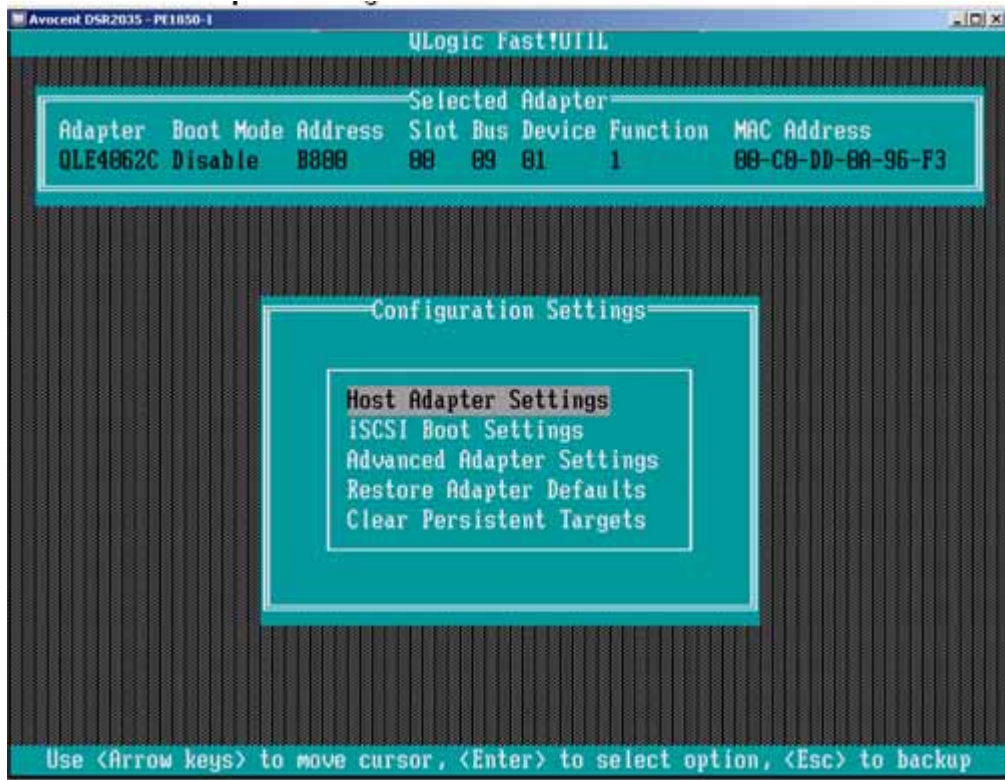
d. Select **Host Adapter Settings**.e. Select the **Initiator iSCSI Name** option.

f. Press **Enter** on the name and type in the new iSCSI name.

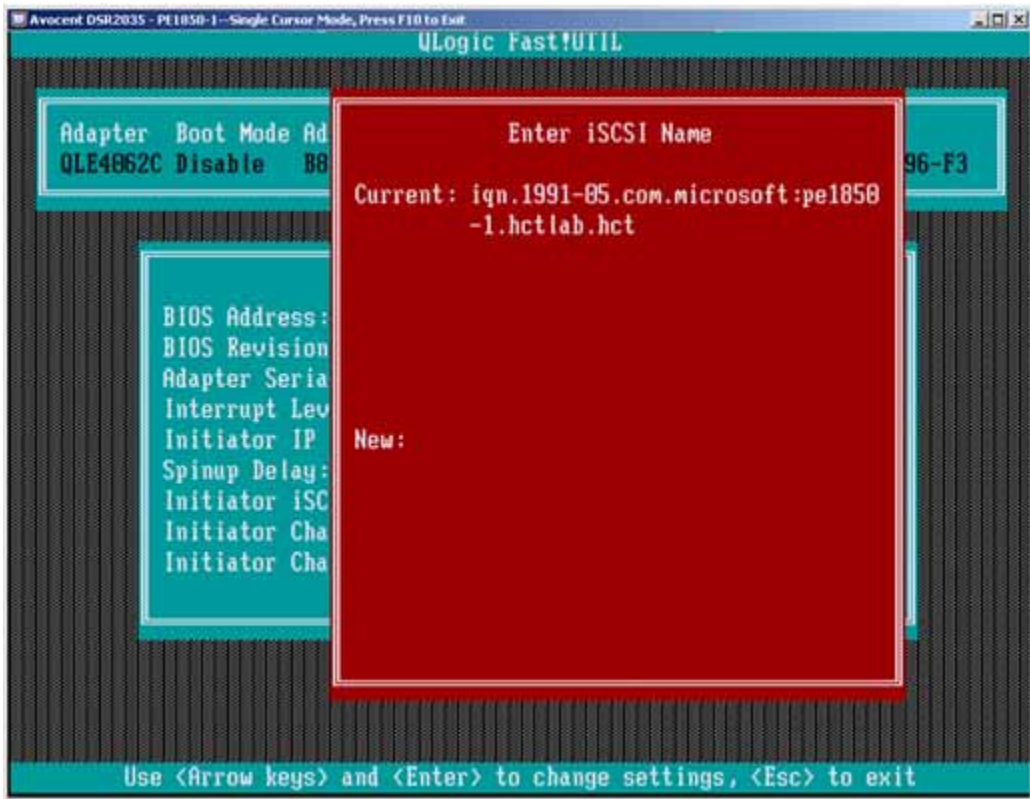

g. Press **ESC** twice and **Save Settings** when prompted. This will force a login to the storage device.

3. Register the new iqn name and add it to your storage group on the VNX series or CLARiiON storage system.

Note: Only register one path. Ensure that the path is from the SP that the lun belongs to. Failing to do so could result in a blue screen during the installation process. You can also refer to VNX series or CLARiiON documentation for a more detailed procedure for setting up Storage Groups and Registering host names.

4. On the host in the **QLogic Fast!Util**, go to the **iSCSI Boot Settings**.

- Under the **Adapter Boot Mode** option, set to **Manual**. This will bring you to the device list page.

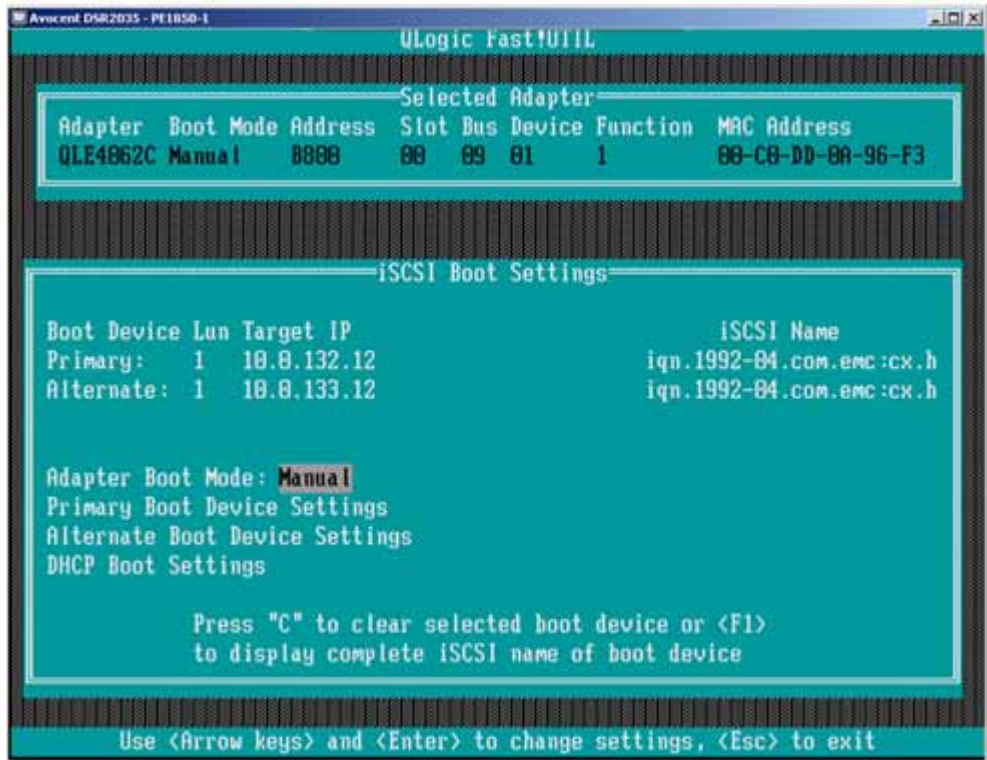

- Under the **Primary Boot Device** option, add the target information, IP address, and iSCSI name.

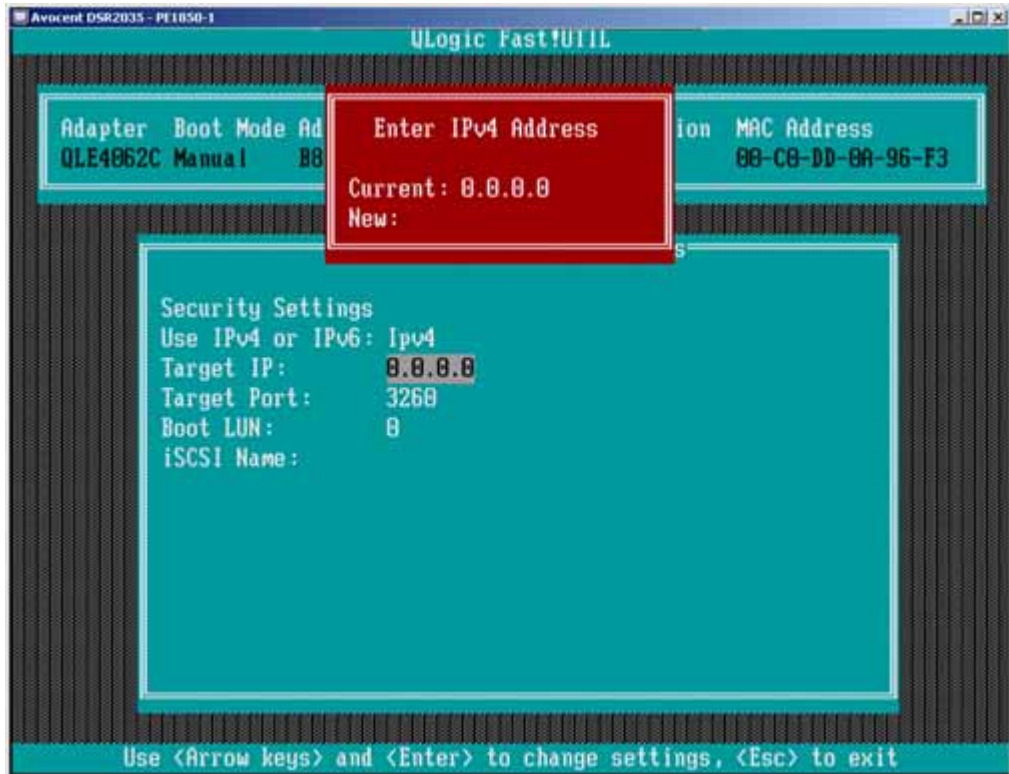

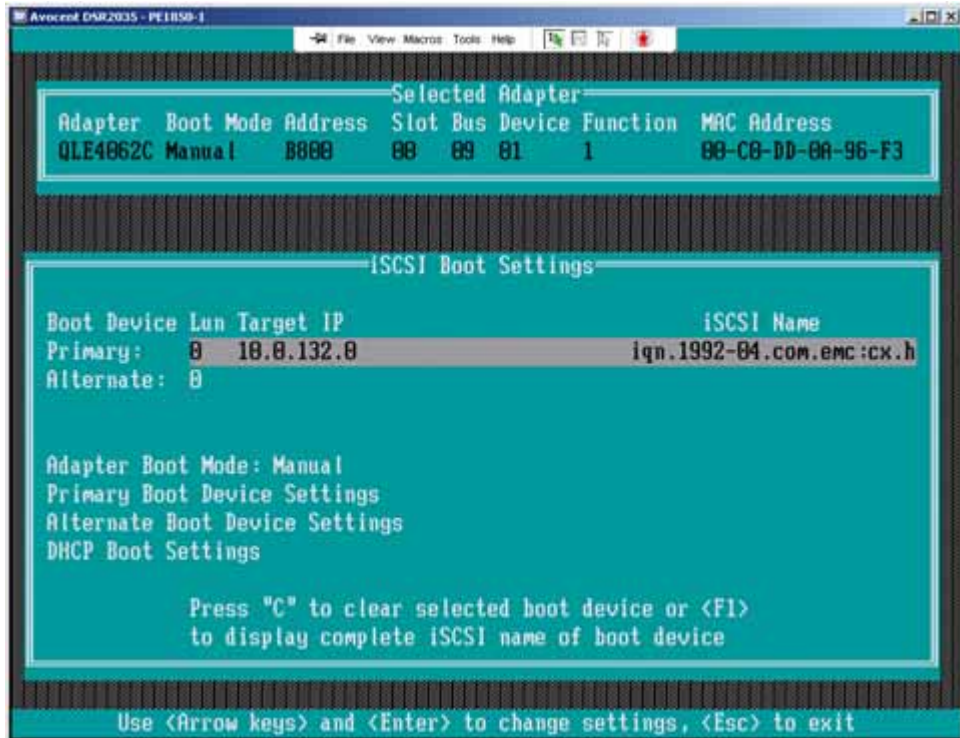
7. Select the **Primary** target information.

8. Select the boot LUN you wish to use.

```

Avocent DMR2035 - PE1850-1 - Single Cursor Mode, Press F10 to Exit
15  No device present  QLogic Fast!UTIL

Scan iSCSI
ID  Vendor  Product  Rev  iSCSI Name
0   No device present
1   No device present
2   DGC     LUN2     8326 iqn.1992-04.com.emc:cx.hk192281
3   No device present
4   No device present
5   EMC     SYMMETRIX 5772 iqn.1992-04.com.emc:5006048ad52
6   No device present
7   No device present
8   No device present
9   No device present
10  No device present
11  No device present
12  No device present
13  No device present
14  No device present

Use <PageUp/PageDown> keys to display more devices, <ESC> to exit

```

9. **Save** all settings and **reboot** the host and **load** the Operating System. Refer to “[Installing the Windows operating system](#)” on page 55.
10. After the operating system is loaded and before the initiator service is loaded, **register** the remaining paths on the CX storage array.
11. Install the **Initiator Service** for Windows 2003 only. Windows 2008 has the iSCSI Initiator Service built in.
12. During the Microsoft Initiator installation, *deselect* the **Software Initiator**. ONLY install the Initiator Service. This will attempt to change the iqn name to fit the Microsoft naming convention. Since this was done in [Step 2](#), it will not blue screen the host for an inaccessible boot device.

Boot-from-SAN configuration restrictions

Refer to the *EMC Support Matrix* for any specific boot-from-SAN restrictions. This guide no longer contains restriction information, and the information in the *EMC Support Matrix* supersedes any restriction references found in previous adapter installation guides.

Further information on booting Microsoft Windows from external storage can be found in the *EMC Host Connectivity Guide for Windows*.

Benefits of booting from the storage array

Benefits of storage-based booting include:

- ◆ Faster replacement/addition of server capacity, enabled by separation of the boot image from the server.
- ◆ Lower investment in internal server-based RAID cards with limited capability.
- ◆ Leveraged investment in the storage network through the high availability, data integrity, and storage management of an external RAID storage system.
- ◆ Leveraged commodity high-density server technology and centralized storage offered by diskless servers using SAN-attached storage systems.

Booting from the EMC storage array works effectively with certain SAN-based environments, including multiserver redundant applications, Web farms, and terminal server applications where an $n+1$ server environment protects customers against different types of failures.

Some applications may not be optimized for storage array-based booting. EMC strongly recommends customers fully investigate their application and data availability requirements and consult with an EMC account team to determine the configuration that best meets their needs.

Setting up external boot for IBM BladeCenter server HS40 (8839)

This section contains the following information:

- ◆ [“Configuring an HS40 BladeCenter server to boot from an external array” on page 157](#)
- ◆ [“Blade server restrictions” on page 158](#)

Configuring an HS40 BladeCenter server to boot from an external array

IBM HS40 (8839) BladeCenter servers encounter a dual-port adapter conflict when attempting to configure boot BIOS to boot from an external array. To configure an HS40 BladeCenter server to boot successfully follow the steps below.

1. Create a single zone containing the adapter port from which you want to boot. This prevents any conflicts with the other fibre port.
2. Configure the QLogic BIOS to boot from the EMC array as described earlier in [“QLogic Fibre Channel adapter BIOS/boot LUN settings” on page 28](#). During server POST, be sure that the QLogic banner displays the selected boot LUN correctly before continuing.
3. Reboot the host and press **F1** to enter the server **BIOS Configuration/Setup Utility**.
4. Select **Devices and I/O Ports** and press **Enter**.
5. Select **IDE Configuration Menu** and press **Enter**.
6. Select the **Onboard PCI IDE Controller** and press **Enter**. Under the options menu, set this IDE Controller to disabled. This will disable the internal IDE disk drives.
7. Press **ESC** twice to return to the **IDE Configuration Menu** and then select **Start Options** and press **Enter**.
8. Select **Startup Sequence Options** and press **Enter**.
9. Select **Third Startup Device** and press **Enter**.
10. Select **HAX PortID xxxxxx xxxxx** and press **Enter**. This boot device will be replaced as the **Third Startup Device** in the **Startup Sequence Options**.
11. Press **ESC** until you are prompted to save your changes. Then exit the **BIOS Configuration/Setup Utility**.

Blade server restrictions

[Table 5](#) describes QLogic software support for the Blade servers.

Table 5 Blade servers/QLogic software support matrix

Blade server manufacturer	SANsurfer Install Wizard for Windows	SANsurfer FC HBA Manager for Windows
Dell	No	Yes
HP	No	Yes
IBM	No	Yes

Manually installing the adapter driver – Advanced users

To use EMC storage array disks with a Windows host, you need an EMC-qualified Fibre Channel adapter driver. The adapter kit includes an EMC-approved driver, which must be installed and configured prior to partitioning the storage array disks. You also should check the QLogic website for the latest EMC-approved version. Refer to [“Downloading latest QLogic drivers/firmware/BIOS files” on page 16](#).

These procedures are necessary if not using the **SANsurfer HBA Install Wizard**. Refer to [“Installing adapter driver and software utilities” on page 76](#).

Where to find the driver

You can find the Fibre Channel adapter driver:

- ◆ On the QLogic CD-ROM that accompanied the adapter. Copy the driver from the OS-specific directory: \Windows2000 or \Windows2003
- ◆ On the QLogic website. Refer to [“Downloading latest QLogic drivers/firmware/BIOS files” on page 16](#)

To ease installation of the driver, unzip the driver file onto a blank diskette.

Required Windows STORPort updates

Currently, the shipping version of Windows requires post-RTM hot fixes to resolve some known issues. For all Windows STORPort installations, you must obtain the current Microsoft QFE hotfix listed in the [EMC Support Matrix](#) with the adapter driver revisions.

IMPORTANT

Install this QFE before installing the adapter driver.

Users planning to upgrade to the latest service pack for Windows should upgrade their adapter drivers to the latest supported version prior to installing the service pack. Always consult the [EMC Support Matrix](#) for the most up-to-date information.

Migrating Windows 2003 drivers from SCSI to STOR

As of April 2006, STORPort has been fully adopted by third-party software and tape vendors and EMC is proceeding towards sole STORPort support under Windows 2003. Adding to the technical benefits of STORPort, phasing-out SCSI miniport on Windows 2003 will provide better coordination of driver version support from OEMs. STORPort will be the common driver platform for all server and storage vendors to provide the customer with compatible solutions.

In the April 2006 *EMC Support Matrix (ESM)*, EMC will make SCSI driver releases for Windows 2003 x86 from QLogic frozen as the last supported Windows 2003 SCSI versions. Once this end-of-life (EOL) is in effect, new installs will still be permitted with the SCSI drivers for three months, but EMC encourages customers to use STORPort instead. Three months after the EOSL (after the June *ESM*) EMC will make these Windows 2003 SCSI versions EOL. Upon EOSL, starting with the July *ESM*, the Windows 2003 SCSI versions will no longer be listed and will not be supported for new installations. Existing customers who have Windows 2003 SCSI already installed will be supported, and any fix or MS HCL support will likely require an upgrade to STORPort. Windows 2000 will continue to use SCSI drivers as the only option.

What to expect when moving from SCSI miniport/Full Port drivers to STORPort drivers

In STORPort drivers, functions or settings that users may have set may no longer be available or may be accessed differently than in the past. These are now controlled by the OS. EMC has always provided standard settings which were accessible via driver configuration utilities. For STORPort drivers, EMC will require that the default settings for STORPort drivers be used unless otherwise instructed. Configuration utilities for STORPort that run under Windows (SANSurfer as well as the Qlogic Ease of Use installation kit), will allow access to settings for the driver that may be changed via the utility if necessary.

Manual driver installation procedure for Windows 2000, 2003, or Windows 2008 hosts

To install the driver into a Windows 2000, 2003, or Windows 2008 host, follow these steps:

1. Boot the host with Windows 2000, 2003, or Windows 2008.
2. Right-click the **My Computer** icon and select **Manage**.
3. In the left pane of the **Computer Management** window (**Server Manager** window on Windows 2008), click the **Device Manager**. (On Windows 2008, the **Device Manager** is located under the **Diagnostics** item.)
4. If Windows Plug-n-Play does not detect your adapter(s), it will be listed as **Unknown** or as a **Fibre Channel Controller** under the **Other Devices** icon in the right pane. If the Windows Plug and Play service has detected your adapter, the adapter will already be listed under **SCSI and RAID Controllers**. (On Windows 2008, they will appear under **Storage Controllers**.) If your adapters have already been detected, follow the instructions under [“Updating the adapter driver in a Windows 2000, 2003, or Windows 2008 hosts” on page 162](#). Otherwise, double-click the first instance of controller under **Other Devices**.
5. In the next window, click **Update Driver**, then **Next**.
6. Perform one of the following:
 - For Windows 2000, click the **Next** button on the welcome screen. On the next screen, you will be asked what you want the wizard to do, click **Display a list of known drivers for this device so that I can choose a specific driver**, and click **Next** then Jump to [Step 7](#).
 - For Windows 2000 & 2003, you will be asked if you wish to connect to Windows Update to search for software, click **No, not at this time**, and click **Next**. On the next screen, you will be asked to install software automatically, or install from a list or generic location. Choose **Install from a list or generic location [Advanced]**, and click **Next**. On the next screen, you are asked to choose your search and installation options, click **Don't search. I will choose the driver to install**, and click **Next**. Select **SCSI & RAID Controllers** from the list, and click **Next** then Jump to [Step 7](#).
 - For Windows 2008, you will be asked how you want to search for the driver. Click **Browse my computer for driver software**. On the next screen, you are given options on how to browse for driver software on your computer, click the option to **Let me pick from a list of device drivers on my computer**. Continue to [Step 7](#).

7. In the next window, click the **Have Disk** button.
8. Enter the path to the diskette containing the driver (A:\, for example), or use the browse function to locate the driver; then click **OK**.
9. Select the appropriate driver for your adapter from the displayed list and click **Next**.

Note: If you select the wrong driver, you will receive an **Incompatible Hardware** warning message. Select **No** to cancel the update and return to the selection windows, and then select the correct driver.

10. If prompted, in the next window, click **Next**.
11. If prompted, click **Yes** to continue the installation. (Windows 2008 may not display this.)
12. Click **Finish** to complete the installation. Windows 2008 has a **Close** button.
13. If the system requests that you reboot the system, select **No**; then click **Close**.
14. If the system again requests that you reboot the system, select **No**; then click **Close**.
15. If you have other adapters to update, select the next adapter in the device manager and repeat steps [Step 6](#) through [Step 14](#).
16. When all adapters have their drivers updated, select **Yes** to the reboot prompt.

If you are not prompted to reboot, reboot your server anyway.

Updating the adapter driver in a Windows 2000, 2003, or Windows 2008 hosts

On Windows 2000, 2003, and Windows 2008 systems where the QLogic adapter has been detected automatically or a driver is already installed, it may be necessary to update the current driver to the latest EMC-qualified driver, as described in this section.

The following procedure assumes that you have copied the latest driver from the QLogic CD-ROM or downloaded it from the QLogic website and put it onto a diskette. Refer to the release notes provided with the driver for information that might be unique to new driver revisions.

To install the driver into a Windows 2000, 2003, or Windows 2008 host:

1. Boot the host (if necessary) with Windows 2000 or Windows 2003.
2. From the Windows taskbar, click **Start> Programs> Administrative Tools> Computer Management**.
3. In the left pane of the Computer Management window, click the **Device Manager** icon.
4. For Windows 2000 and 2003, double-click the **SCSI & RAID Controllers** icon. For Windows 2008, double-click the **Storage Controllers** icon.
5. Under **SCSI & RAID Controllers** or **Storage Controllers**, double-click the adapter you want to upgrade.
6. In the next window, click the **Driver** tab; then click **Update Driver**.

7. Perform one of the following:
 - For Windows 2000, click the **Next** button on the welcome screen. On the next screen, you will be asked what you want the wizard to do. Click **Display a list of known drivers for this device so that I can choose a specific driver** and then click **Next**. Continue to [Step 8](#).
 - For Windows 2000 and 2003, you will be asked if you wish to connect to Windows Update to search for software. Click **No, not at this time** and then click **Next**. On the next screen, you will be asked to whether you want to install software automatically or to install software from a list or generic location. Choose **Install from a list or generic location [Advanced]** and click **Next**. On the next screen, you are asked to choose your search and installation options. Click **Don't search. I will choose the driver to install** and then click **Next**. Select **SCSI & RAID Controllers** from the list and then click **Next**. Continue to [Step 8](#).
 - For Windows 2008, you will be asked how you want to search for the driver. Click **Browse my computer for driver software**. On the next screen, you are given options on how to browse for driver software on your computer. Click the option **Let me pick from a list of device drivers on my computer**. Continue to [Step 8](#).
8. In the next window, click **Have Disk**.
9. Enter the path to the diskette containing the driver (A:\, for example), or use the browse function to locate the driver; then click **OK**.
10. Select the appropriate driver for your adapter from the displayed list and click **Next**.

Note: If you select the wrong driver, you will receive an **Incompatible Hardware** warning message. Select **No** to cancel the update and return to the selection windows, and then select the correct driver.

11. If prompted in the next window, click **Next**. (Windows 2008 may not display this.)
12. If prompted, click **Yes** to continue the installation. (Windows 2008 may not display this.)
13. Click **Finish** to complete the installation. Windows 2008 will have a **Close** button.

14. If the system requests that you reboot the system and you have other adapters to update, select **No** and then click **Close**.
15. If the system again requests that you reboot the system and you have other adapters to update, select **No** and then click **Close**.
16. If you have other adapters to update, select the next adapter under **SCSI & RAID Controllers** and repeat **Step 6** through **Step 15**.
17. When all adapters have their drivers updated, select **Yes** to the **reboot** prompt.

If you are not promoted to reboot, reboot your server anyway.

For more information on connecting to a SAN and installing drivers/firmware on HP Proliant BL p-Class server blades, refer to HP documentation on the HP Business Support site at <http://h20000.www2.hp.com/bizsupport/TechSupport/Home.jsp>.

Upgrading to Windows 2003 from Windows 2000

Note the following if upgrading to Windows 2003:

- ◆ Upgrading from Windows 2000 - The Windows 2000 drivers may be preserved while upgrading to Windows 2003. These SCSI Port drivers (including the native Windows 2003 SCSI Port drivers) are not supported by EMC for Windows 2003. You should obtain the correct Windows 2003 drivers. Refer to “[Downloading latest QLogic drivers/firmware/BIOS files](#)” on page 16, and reinstall the drivers after the upgrade is complete.
- ◆ Currently, to upgrade from Windows 2000 to Windows 2003, you must first uninstall PowerPath. After upgrading the host, you can reinstall an approved Windows 2003 version. Please refer to the EMC PowerPath documentation for further details. You may wish to disconnect your storage during the Windows upgrade, and reconnect it after the approved Windows 2003 drivers are installed.

Editing the Windows time-out value

While QLogic drivers will set the Windows disk timeout value to 60 seconds automatically, some software applications may change the timeout value to another value. The following procedure describes how to manually change the Windows disk timeout value to 60 seconds.

Connecting a Windows host to an EMC storage array over Fibre Channel requires editing the Windows registry as follows:

1. Open the registry:
 - a. On the Windows taskbar, click **Start**.
 - b. Click **Run**.
 - c. Type **regedt32.exe** in the **Open** field and click **OK**.
2. Follow this path:

```
HKEY_LOCAL_MACHINE\ System\ CurrentControlSet\,  
Services\ Disk
```
3. Look for the **TimeOutValue** entry in the right pane of the registry editor window:
 - If the **TimeOutValue** exists, double-click it, then go to step 4.
 - If the **TimeOutValue** does *not* exist:
 - a. Select **Add Value** from the **Edit** menu.
 - b. In the **Value Name** box, type **TimeOutValue** (exactly as shown).
 - c. For the data type, select **REG_DWORD** from the pull-down menu.
 - d. Click **OK**.
4. In the **DWORD Editor** window:
 - a. Click **decimal** in the **radix** box.
 - b. Change the value in the **data** box to **60**.
5. Click **OK**.
6. Close the registry editor.
7. Reboot the host.

QLogic advanced utilities

This section contains the following information:

- ◆ [“Updating QLogic firmware/BIOS and applying NVRAM settings”](#), next
- ◆ [“Updating the flash BIOS using SANsurfer FC HBA Manager” on page 168](#)
- ◆ [“Updating the flash BIOS using SANsurfer FC HBA Manager” on page 168](#)
- ◆ [“Procedure for replacing a QLogic adapter in Stratus ftServers without rebooting” on page 171](#)

Updating QLogic firmware/BIOS and applying NVRAM settings

EMC-approved adapter firmware/BIOS and NVRAM settings must be applied to your adapter before connecting to, and running I/O on, EMC Storage Arrays. There are two ways to flash updated firmware/BIOS files to your adapter:

- ◆ From QLogic SANsurfer Management Software
- ◆ From a DOS command prompt.

To use SANsurfer Management Software to update firmware/BIOS on your adapter when Windows is running, refer to [“Updating the flash BIOS using SANsurfer FC HBA Manager” on page 168](#) for instructions.

Note: Current 64-bit systems can on be updated only with QLogic SANsurfer Management Software.

Note: QLogic SANsurfer Management Software is compatible with Fibre Channel HBAs and Fibre Channel over Ethernet (FCoE) CNAs. The procedures in this section will work for both types of adapters.

If you are updating the firmware/BIOS of an adapter installed in a 32-bit system that is not running the SANsurfer software, use the procedure described in the [“Install/upgrade firmware and boot BIOS from DOS” on page 27](#).

Updating the flash BIOS using SANsurfer FC HBA Manager



WARNING

Changing flash BIOS incorrectly can cause serious damage to your system.

Perform the following steps to update the flash BIOS:

1. In the SANSANsurfer FC HBA Manager main menu HBA tree, select the adapter.

If you want to configure multiple adapters with the same settings, hold the **CTRL** key while selecting multiple adapters. The adapters must be in the same series:

QLA231x adapters, QLA234x adapters, QLA246x adapters, QLE246x adapters, or QLA22xx adapters.

Note: Only the Settings (Adapter Settings and Advanced Adapter Settings) and Utilities tabbed pages can be configured for multiple adapters; therefore, the remaining tabbed pages do not display when multiple adapters are selected.

2. Click the **Utilities** tab. The Utilities page displays (see [Figure 123 on page 169](#)).

IMPORTANT

If you selected multiple adapters, the Save Flash and Save NVRAM radio buttons do not display. These options cannot be performed with multiple adapters. Some versions of SANsurfer may have buttons referring to Flash, Option ROM, or Boot Code. These all refer to the adapter BIOS.



Figure 123 Utilities tabbed page

The identifying information displays:

- **Host:** Name of the host connected to the adapter.
 - **Adapter:** Adapter number and type.
 - **Node Name:** World Wide adapter node name.
 - **Port Name:** World Wide adapter port name.
 - **Port ID:** Port ID of the adapter.
3. Click the **Update Entire Image** button to update the Boot BIOS. Since EMC kits are provided as universal kits, the entire flash image must be used.
 4. Select the file that contains the flash BIOS. You can obtain this file from the QLogic website. Refer to “[Downloading latest QLogic drivers/firmware/BIOS files](#)” on page 16. The file typically ends

with .bin, such as ql22rom.bin. If you select a file that is not an acceptable flash BIOS file for the adapter, the **not an acceptable flash BIOS** data file message displays. Select a valid file, then click **OK**.

5. The **Security Check** dialog box displays. In the **Enter Password** box, type the password. Click **OK**.
6. The tabbed page appears dimmed during the update. When complete, the flash BIOS update complete message displays.
7. Reboot the system.

Note: NVRAM settings for the adapter are updated using the **Update** button under the **HBA Parameters** section of the **Utilities** screen.

Procedure for replacing a QLogic adapter in Stratus ftServers without rebooting

This section contains the following information:

- ◆ [“EMC VNX series or CLARiiON storage systems”](#), next
- ◆ [“EMC Symmetrix arrays with device masking enabled” on page 172](#)

EMC VNX series or CLARiiON storage systems

Use of this procedure requires NAVICLI installed on the host system.

1. Remove the IO slice that contains the defective QLogic adapter.
2. Replace the defective adapter with a new adapter of same Stratus part number (that is, U525 or U526). The adapter should be inserted into the same PCI slot from which the defective adapter was removed. (Inserting the replacement adapter into another PCI slot requires a driver to be loaded for the adapter.)
3. Reinsert IO slice with the new adapter, and reconnect all cables.
4. Power up the ftServer, and let the IO Slice come online and duplex, as shown in the Stratus ftServer Management tool.
5. Change the FC switch zoning to add the WWN of the replaced adapter to the appropriate zones.
6. Restart the Unisphere/Navisphere Agent using the **Service Control Manager** applet.
7. In the Unisphere/Navisphere Manager, use connectivity status to verify the new adapter is present and logged in. Alternately, use the port **'list'** command in **navicli**.
8. Using **navicli**, connect the adapter to the storage group with the following command:

```
navicli -h <Clariion IP Addr> storagegroup -connecthost  
-host <host-name> -gname <Storage-group-name>
```

This command will give the user the following prompt:

```
Connect host <host-name>to storage group  
<Storage-group-name> (y/n)?
```

Type `y`.

9. Scan for hardware changes from the Windows device manager.
10. Execute the following commands from a command window:

```
powermt restore
powermt display
```

At this point, two adapters should be present in the display and the FC adapters should be duplexed in the ftSMC. It may be necessary to repeat steps 9 and 10.

EMC Symmetrix arrays with device masking enabled¹

Use of this procedure requires SYMCLI installed on the host system (part of the EMC Solutions Enabler suite). Alternatively, EMC ControlCenter can be used to perform the adapter replacement.

1. Using SYMCLI, run `symmask list logins` to view the old WWN/iSCSI adapters.
2. Remove all cables to the IO slice with the defective adapter, and remove the IO slice.
3. Replace the defective QLogic adapter with the new adapter of same Stratus part number (that is, U525 or U526). The adapter should be inserted into same PCI slot from which the defective adapter was removed. (Inserting the replacement adapter into another PCI slot requires a driver to be loaded for the adapter.)
4. Reinsert the IO slice with the new adapter, and reconnect all cables.
5. Let the IO Slice come online and duplex, as shown in the Stratus ftServer Management tool.
6. Change the FC switch zoning to add the WWN of the replaced adapter to the appropriate zones.
7. Run `symmask list hba` or `discover` to view the new initiator (for example, WWN).

-
1. Symmetrix Arrays without device masking enabled do not require this procedure; Symmetrix Arrays with device masking enabled only require replacing the adapter WWN used in switch zoning.

8. Run **symmask replace** to substitute a new WWN for all occurrences in the database of the old WWN.
9. Run **symmask discover** to establish the new names in the history table, or run **symmask rename** to assign a WWN to the new adapter in both the database and the history table.
10. Run **symmask refresh** to update the director profile tables (in cache) from the database.
11. Scan for hardware changes from the Windows device manager.
12. Execute the following commands from a command window:

```
powermt restore  
powermt display
```

At this point, two adapters should be present in the display and the FC adapters should be duplexed in the ftSMC. It may be necessary to repeat steps 9 and 10.

Special instructions for the EMC CLARiiON CX200 series

This section contains the following information:

- ◆ “Set the adapter FC-AL loop ID” on page 174
- ◆ “Direct-connect dual-host clustering configurations” on page 176

Set the adapter FC-AL loop ID

While configuring a QLA234x adapter for Windows 2000 and connection to CLARiiON CX200 series for direct-connect cluster configurations, you must manually set the adapter FC-AL Loop ID. Follow these steps to enable loop hard addressing and set the loop ID on each adapter:

Perform this procedure on all nodes in the cluster connected to the CX200 series array.

1. Boot the Windows host; press **Ctrl-Q** when prompted to **Press <CTRL-Q> for Fast!UTIL**. (This prompt appears with the QLogic startup banner.)
2. After the **Fast!UTIL** program loads, the initial display depends on whether there are multiple QLogic adapters installed in the server:
 - If there is only one QLogic adapter, the **Fast!UTIL Options** menu appears.
 - If there are multiple QLogic adapters, a list of memory addresses occupied by those adapters appears.
Using the arrow keys, select the desired adapter and press **Enter**. The **Fast!UTIL Options** menu appears.
3. Select **Configuration Settings** from the **Fast!UTIL Options** menu, and press **Enter**.
4. Select **Host Adapter Settings** from the **Configuration Settings** menu.
5. Select **Adapter Hard Loop ID** from the **Host Adapter Settings** menu and press **ENTER** until the value is **Enabled**.
6. Select **Hard Loop ID** and press **Enter**.

The loop ID value entered here is the decimal representation of the FC-AL loop ID. You do not need to perform any FC-AL AL_PA hexadecimal translation.

adapters connected to the same SP should all have unique hard loop IDs. Select **0** for all adapters on one node, select **1** for all adapters on the next node, and so on.

7. Enter a value for the loop ID and press **Enter**.
8. Press Esc to return to the **Configuration Settings** menu.
9. Press Esc to return to the **Fast!UTIL Options** menu.
10. When prompted to save changes made to the current adapter, select **Save Changes** and press **ENTER**.
11. If there are more adapters to configure, choose **Select Host Adapter**, and repeat steps **3** through **11** for each adapter.
12. Press Esc to exit Fast!UTIL.
13. Reboot the host.
14. Repeat this procedure on all nodes in the cluster connected to the CX200 series array.
15. While you are in the BIOS, you can verify that the topology is set correctly for direct connect (FC-AL).

IMPORTANT

Future use of the firmware NVRAM file to apply settings will overwrite and possibly invalidate the changes made above. If you will later update using a firmware NVRAM file, be sure it is listed and supports this CX200 series direct-connect cluster configuration.

Note: To restore EMC default adapter settings, either reload the approved EMC NVRAM file, or return to step **5** and ensure **Adapter Hard Loop ID** is set to **Disabled**.

Direct-connect dual-host clustering configurations

For CLARiiON CX200 series direct-connect dual-host cluster configurations only with QLA234x adapters, you must follow all procedures described in this section.

Check for an updated adapter driver

For CLARiiON CX200 series direct-connect dual-host cluster configurations with only QLA234x adapters, you may need a separate driver and firmware download. The [EMC Support Matrix](#) notes whether separate driver and firmware files are required.

For each adapter determined to require updated firmware and drivers, follow the instructions on [“Downloading latest QLogic drivers/firmware/BIOS files” on page 16](#). Be sure to reference the Name and Description fields to select the correct CX200 series direct-connect dual-host cluster-compatible files.

Reconfigure the adapter jumper

For CLARiiON CX200 series direct-connect dual-host cluster configurations with only QLA234x adapters, you must change the default adapter optic jumper position:

IMPORTANT

Modifying the jumper setting without using the recommended firmware/drivers can cause the adapter to lose connectivity.

1. Remove the adapter from the server as instructed by your server guide.
2. Locate jumper(s) J3 (QLA2340) or J3 and J4 (QLA2342), shown in [Figure 124 on page 177](#).

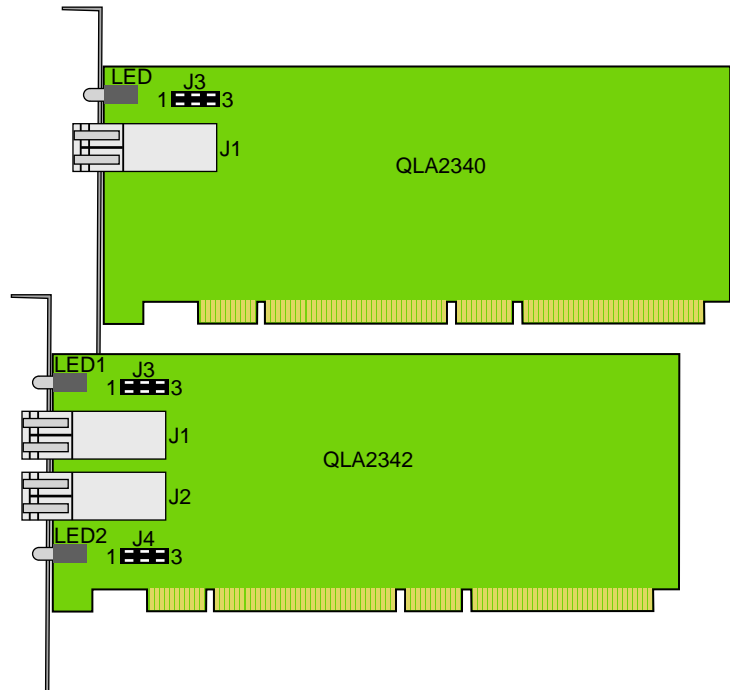

Figure 124 Reconfigure the adapter jumper

3. Move the jumper(s), onto pins 1-2 (if not already there).

If later you wish to return the jumper(s) to the default factory position, repeat step 2, returning the jumper to pins 2-3.

QLogic NPIV solution

NPIV allows a single physical FC HBA port to function as multiple logical ports, each with its World Wide Port Name (WWPN). An example is shown in [Figure 125](#).

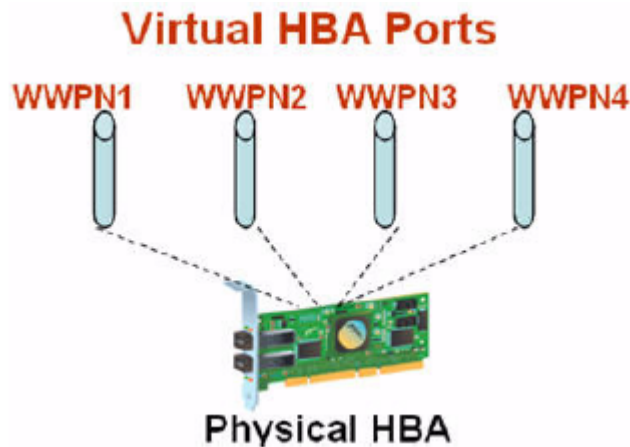

Figure 125 N_Port ID sharing

QLogic FC adapter NPIV solution

To complement Microsoft and other server virtualization software solutions, QLogic has extended virtualization capabilities to the HBA hardware through NPIV. All QLogic 2400 and 2500 series FC adapters implement and support NPIV. QLogic provides support for creating, deleting, and managing NPIV ports through its SANsurfer FC HBA Manager tool.

With the combined QLogic and Microsoft solution, storage administrators can create virtual HBA ports within multiple zones and assign them to VMs for migration without having to reconfigure any zoning or LUN masking settings. This solution creates a virtualized network that is easier to manage and maintain. In addition, support for Microsoft's virtualization solutions combined with QLogic's HBA virtualization technologies further increase hardware utilization and enables organizations to rapidly configure and deploy Virtual Machines.

Benefits of the QLogic NPIV solution include:

- ◆ Lower Total Cost of Ownership (TCO)
- ◆ Increased security and flexibility
- ◆ Simplified Virtualization Management
- ◆ Higher availability

For more information about setting up and configuring NPIV with your QLogic FC adapter, refer to *QLogic's Fibre Channel HBA and VM Migration for Hyper-V & SC VMM2008 – Quick Start Guide* located on the QLogic website (<http://www.qlogic.com>) in the downloads area for QLogic 2400 series (4 Gb) or 2500 series (8 Gb) FC adapters.

This chapter contains information on troubleshooting problems and known issues.

- ◆ Operating system/driver capabilities and limitations 182
- ◆ Extended error logging by QLogic drivers 184
- ◆ Understanding persistent binding 185
- ◆ Understanding queue depth 188
- ◆ Known issues 190
- ◆ Problems and solutions 191
- ◆ Event codes from the QLogic STORPort driver 194

Operating system/driver capabilities and limitations

The following capabilities and limitations should be noted for Windows operating systems with QLogic adapters.

LUNs

Theoretically, Windows supports up to 261,120 total LUNs. This figure is based on the listed support limitations for Windows Server from Microsoft: 8 buses per adapter, 128 targets per bus, and 255 LUNs per target. However, due to registry hive limitations, a Windows server is most likely to run out of registry space to keep track of these large LUN counts well before reaching this limit. Windows 2000 has this registry size issue. See Microsoft knowledge-base articles 292726 and 269075 for information. Windows 2003 does not have this issue.

Microsoft Windows limits the number of LUNs per adapter to 255 (LUNs 00-FE) even though the adapters are capable of presenting 256 (LUNs 00-FF). It is a function of the operating system that prevents that last LUN from being presented to the user, and not the adapter or driver. This limitation should be taken into consideration when planning your host configuration.

Based on E-Lab testing, it has been determined that for EMC configurations, Windows servers should be limited to a maximum of 500 LUNs. In most cases, this number will be more than sufficient. In others, it may be deemed too small. For configurations where a large amount of storage is necessary, but not necessarily a large number of disks, EMC storage can be configured to present LUNs of large sizes to the host

Volume sizes

Windows 2000 supports a maximum file system size of 2 TB (terabytes.)

Windows 2003 and Windows 2008 support a maximum file system size of 2 TB unless Service Pack 1 or later is installed. With SP1 or later, the maximum supported physical disk size is 256 TB.

Note: Volumes larger than 2 TB must use GPT partitions to support them. Refer to your Windows users guide for information on GPT partitions.

Note: Windows for x64 servers does not require SP1 or later to create GPT partitions.

EMC storage arrays provide the ability to expand the size of a LUN presented to the host server. Refer to your EMC array's documentation for procedures on expanding LUN sizes. Windows has the ability to recognize the extra space on these expanded LUNs by performing a rescan via the Disk Administrator window.

Extended error logging by QLogic drivers

In driver versions prior to the 9.X family, additional messages were logged in the system event log when the "extended error logging" parameter was enabled in the adapter BIOS. The messages were primarily informational, but often confused users by appearing to be legitimate error messages.

Driver family 9.X and beyond will no longer log these additional messages in the event log even if the "extended error logging" parameter is enabled. New tools have been developed for developers and engineers troubleshooting customer problems without the need for these messages. Visit the website http://www.qlogic.com/support/logs/event_log.asp for information about QLogic event messages.

Understanding persistent binding

Persistent binding is the mechanism to create a continuous logical route from a storage device object in the Windows host to a volume in the EMC storage array across the fabric.

Without a persistent binding mechanism, the host cannot maintain persistent logical routing of the communication from a storage device object across the fabric to an EMC storage array volume. If the physical configuration of the switch is changed (for example, the cable is swapped or the host is rebooted), the logical route becomes inconsistent, causing possible data corruption if the user application is modifying data through inconsistent logical routing of the communication from the driver entry point to a volume in an EMC storage array across the fabric.

The Windows operating system (OS) does not provide a satisfactory means to allow persistent binding. Most software applications access storage using file systems managed by the Windows OS. (File systems are represented as <drive letters> <colons>, that is, **C:**, **D:**, and so forth.) For storage devices containing file systems, Windows writes a disk signature to the disk device. The operating system can then identify and associate with, a particular drive letter and file system.

Since the signature resides on the disk device, changes can occur on the storage end (a cable swap, for example) that can cause a disk device to be visible to the host server in a new location. However, the OS looks for the disk signature and, providing that nothing on the disk changed, associate the signature with the correct drive letter and file system. This mechanism is strictly an operating system feature and is not influenced by the Fibre Channel device driver.

Some software applications, however, do not use the Windows file systems or drive letters for their storage requirements. Instead they access storage drives directly, using their own built-in “file systems.” Devices accessed in this way are referred to as *raw devices* and are known as *physical drives* in Windows terminology.

The naming convention for physical drives is simple and is always the same for software applications using them. A raw device under Windows is accessed by the name `\\.\PHYSICALDRIVEXXX`, where **XXX** is the drive number. For example, a system with three hard disks attached using an QLogic Fibre Channel controller assigns the disks the names `\\.\PHYSICALDRIVE0`,

\\.\PHYSICALDRIVE1, and \\.\PHYSICALDRIVE2. The number is assigned during the disk discovery part of the Windows boot process.

During boot-up, the Windows OS loads the driver for the storage adapters. Once loaded, the OS performs a SCSI **Inquiry** command to obtain information about all the attached storage devices. Each disk drive it discovers is assigned a number in a *semi-biased* first come, first serve fashion based on adapter. (*Semi-biased* means that the Windows system always begins with the controller in the lowest-numbered PCI slot where a storage controller resides. Once the driver for the storage controller is loaded, the OS selects the adapter in the lowest-numbered PCI slot to begin the drive discovery process.)

It is this naming convention and the process by which drives are discovered that makes persistent binding (by definition) impossible for Windows. Persistent binding requires a continuous logical route from a storage device object in the Windows host to a volume in an EMC storage array across the fabric. As mentioned above, each disk drive is assigned a number in a first-come, first-serve basis. This is where faults can occur.

Example Imagine this scenario: A host system contains controllers in slots 0, 1, and 2. Someone removes a cable from the QLogic controller in host PCI slot 0, then reboots the host.

During reboot, the Windows OS loads the QLogic driver during reboot and begins disk discovery. Under the scenario presented above, there are no devices discovered on controller 0, so the OS moves to the controller in slot 1 and begins naming the disks it finds, starting with \\.\PHYSICALDRIVE0. Any software applications accessing \\.\PHYSICALDRIVE0 before the reboot will be unable to locate their data on the device, because it changed.

The following figure shows the original configuration before the reboot. adapter 0 is in PCI slot 0 of the Windows host. Each adapter has four disk devices connected to it, so Windows has assigned the name \\.\PHYSICALDRIVE0 to the first disk on adapter 0. Each disk after that is assigned a number in sequence as shown in [Figure 126 on page 187](#).

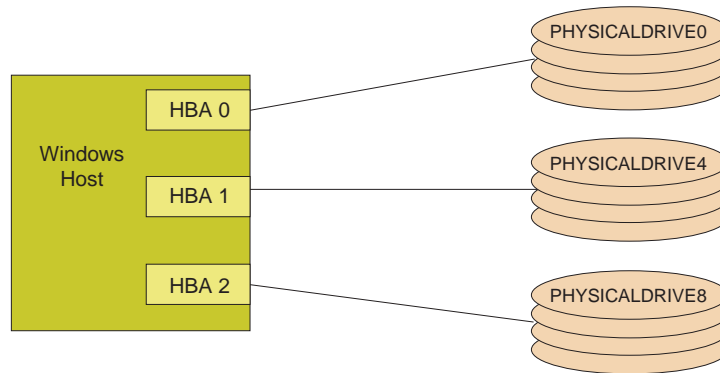

Figure 126 Original configuration before the reboot

Figure 127 shows the same host after the cable attached to adapter0 has been removed and the host rebooted. Since Windows was unable to do a discovery on adapter 0, it assigned `\\.\PHYSICALDRIVE0` to the first device it discovered. In this case, that first device is connected to adapter1. Due to the shift, any software application accessing `\\.\PHYSICALDRIVE0` will not find data previously written on the original `\\.\PHYSICALDRIVE0`.

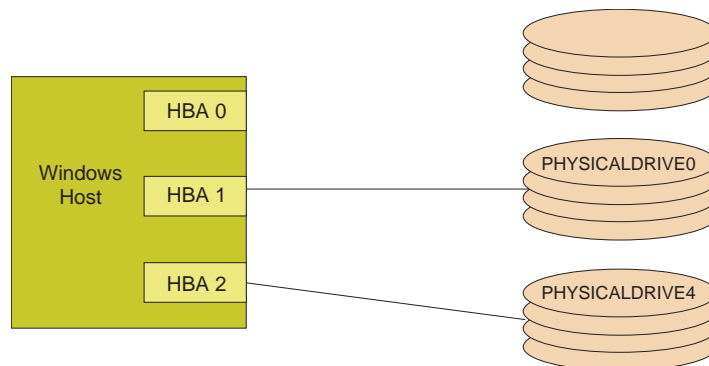

Figure 127 Host after the rebooted

The default driver behavior does not store target bindings between host reboots. The bindings are dynamically generated by the adapter when new target devices are detected.

Note: Tape devices are treated the same as disk devices in Windows with respect to persistent binding. Refer to your tape device documentation for more information.

Understanding queue depth

Each port on EMC storage arrays has a maximum queue depth. The performance implications in a large fabric environment with many HBAs (initiators) generating I/Os is that a storage port's queue can quickly fill up to the maximum. When this happens, the HBA will be notified by the array with queue full (QFULL) messages and result in very poor response times. Various operating systems deal with queue full differently.

Windows operating systems with STORPort drivers will throttle I/Os down to a minimum in an attempt to prevent filling the queue. When the queue full messages subside, STORPort will increase the queue depth again. This could take up to around a minute in some instances, depending on the load. The performance of the server's applications will be impacted, sometimes to the point of hanging or crashing if it happens repeatedly or for a prolonged amount of time.

In order to avoid overloading the storage array's ports, you can calculate the maximum queue depth using a combination of the number of initiators per storage port and the number of LUNs ESX uses. Other initiators are likely to be sharing the same SP ports, so these will also need to have their queue depths limited. The math to calculate the maximum queue depth is:

$$QD = \text{Maximum Port Queue Length} / (\text{Initiators} * \text{LUNs})$$

For example, there are 4 servers with single HBA ports connected to a single port on the storage array, with 5 LUNs masked to each server. The storage port's maximum queue length is 1600 outstanding commands. This leads to the following queue depth calculation:

$$\text{HBA Queue Depth} = 1600 / (4 * 20)$$

In this example, the calculated HBA queue depth would be 20. A certain amount of over-subscription can be tolerated because all LUNs assigned to the servers are unlikely to be busy at the same time, especially if additional HBA ports and load balancing software is used. So in the example above, a queue depth of 32 should not cause queue full. However, a queue depth value of 256 or higher could cause performance issues.

Using this example, it is easy to extrapolate the potential performance implications of large server environments with large numbers of servers and initiators. This includes virtualized environments like Hyper-V that use synthetic/virtual Fibre Channel adapters and NPIV

environments, where there are a number of virtual initiators connecting through the same physical HBA port. EMC's approved settings ([“Pre-configured settings” on page 37](#)) are meant to be guidelines based on qualification test work performed by EMC engineering. Each environment is different, however, so it is important to review and pre-plan your environment, possibly adjusting your queue depth setting to allow for better performance in your environment.

Note: QLogic HBAs use the term 'Execution Throttle' for the queue depth setting.

Known issues

Be aware of these issues:

- ◆ QLogic BIOS 1.26 and later for QLA23xx and BIOS 1.79 and later for QLA22xx adapters allow for multiple **Boot Port Name** entries to be configured for high-availability booting after path failures. Previous BIOS versions do not support this functionality, will boot only from a single storage array port, and cannot provide boot capability with path failures.
- ◆ NTOSKNL BSOD (blue screen) during a link-down event can cause file system corruption to mounted file systems.
- ◆ adapter boot BIOS does not support high availability while the OS is booting. It can handle path failures at boot initialization time, and after the OS has loaded. Path failures while the OS is loading will require the host to reboot before successfully completing the boot process.
- ◆ Degraded response time as the I/O load approaches storage system capacity can make the OS appear hung or result in a NTOSKNL BSOD.
- ◆ Boot files, Windows system files, and swap space should all be on the boot LUN. With certain server models, you can use an internal disk for the page file for stability; however, this might not increase fault tolerance and might reduce system recovery options.
- ◆ Swap space must be available on %SYSTEMROOT% or core dump will fail.
- ◆ For Windows 2003 on 64-bit IA64-2 servers, the system no longer uses an x86-compatible BIOS; therefore, enabling boot-from-array support with the adapter requires a separate firmware EFI download.
- ◆ For servers booting from the array, a Symmetrix out-of-family microcode load, VNX OE for block, or a CLARiiON FLARE® NDU between versions will cause the server to require a reboot. This occurs because Windows requires a reboot when characteristics of the boot LUN change. During the NDU process on EMC storage arrays, the serial number and inquiry VPD data will change to reflect the new code version. When Windows performs a rescan and recognizes this change, it assumes a change has occurred on the boot LUN and will require a reboot.

Problems and solutions

This section contains known problems and solutions.

Problem 1

Error Message ID: 51 — In the event viewer when attempting to install multiple host access (for clustering) to the same EMC VNX series or CLARiiON storage group. The text of the message reads:

```
An Error was detected on device \Device\Harddisk<x>\DR<x>
during a paging operation
```

Solution

Until host cluster software is installed, only a single host should access a storage group at a time. Refer to the [EMC Support Matrix](#) for supported host configurations.

Problem 2

EMC Knowledge base solution emc29097 — If using adapters connected to both VNX series or CLARiiON SPs, without PowerPath installed, duplicate LUNs will be visible in the Device Manager and Disk Manager. Only one instance of the LUN will be accessible, and all other matching mappings will be listed as Unknown, Unreadable, and Unallocated.

Solution

This is normal behavior when multiple paths are available, PowerPath is not installed, and the initiator type is registered in PowerPath mode (array default depending on core code revision).

Problem 3

EMC Knowledgebase solution emc69307 — When using QLogic adapters in a Brocade fabric environment, after upgrading Brocade 3900-series switch firmware to 3.0.2m, the adapters report repeated link errors, and intermittently lose fabric connectivity.

PowerPath may report paths lost and then found in quick succession, and repeated Windows 2000 event log error entries for Link Down/Link Up events similar to the following:

```
Event ID: 11
Source: ql2300
Description: The driver detected a controller error on \Device\Scsi\ql2300x.
Data (words): offset 34 = 80120000 [ErrorCode: Link down error]
```

```
Event ID: 11
Source: ql2300
Description: The driver detected a controller error on \Device\Scsi\ql2300x.
```

Data (words): offset 34 = 80110000 [ErrorCode: **Link up**]

Solution Upgrade to the latest adapter driver. This was corrected for Windows 2000 in 8.2.2.25 and later drivers. Windows 2003 driver 8.2.2.20 and later already contain this correction.

Problem 4

EMC Knowledge base solution emc69308 — Direct-connect to EMC CLARiiON CX200 reports incorrect queue full error messages. Even under light I/O, a host may log a message noting that disk has reached a queue-full state similar to the following in the Windows event viewer:

Event ID: 11
 Source: ql2300
 Description: The driver detected a controller error on \Device\Scsi\ql2300x.
 Data (words): offset 34 = F003001C [ErrorCode: Target device queue full].

Solution Upgrade to the latest adapter driver. This was corrected in version 8.2.2.25 and later drivers.

Problem 5

Windows 2000 hosts running less than SP4 could be susceptible to data loss during LUN expansion operations.

Solution This issue is corrected by Microsoft in SP4, or by applying hot fix 327020. Refer to EMC Knowledge base solution emc73538 and Microsoft Knowledge Base article 327020 for more information.

Problem 6

For Windows 2003, the STORPort drivers 8.2.3.26 with Microsoft hotfix Q823728 and earlier do not yet fully support all Microsoft VSS functions.

Solution This was first corrected in Microsoft QFE hot fix Q837413 and to be used with minimum 8.2.3.27 driver. You should also use minimum Microsoft VSS QFE 833167.

Problem 7

When using SANsurfer 2.0.25 to update to BIOS 1.4x, you receive the message as follows:

```
Incorrect BIOS file selected.  
The selected BIOS file does not match the selected HBA type.  
Check your file and try again.
```

Solution SANsurfer 2.0.25 does not support flashing the 1.4x BIOS, you need to use the DOS FLASUTIL utility. This will be corrected in a future SANsurfer release.

Problem 8

IBM eServer BladeCenter HS20 Fibre Channel Expansion Card 48P7061 may not update all adapter BIOS in the system when using FLASUTIL.

Solution You may need to run FLASUTIL multiple times, and use /F to specify specific adapters to update. Refer to the FLASUTIL instructions for further information.

Problem 9

Certain builds of SANsurfer running on Windows 2008 will cause event ID 7030 to appear in the system event log.

Solution Windows 2008 no longer supports interactive services. The QLogic QLManagement Agent for SANsurfer is an interactive service. This event message, while annoying, is harmless to the functionality of the software and operating system. EMC and QLogic do not recommend removing the service as it may affect the adapter driver.

Event codes from the QLogic STORPort driver

QLogic STORPort drivers often place driver event codes in the Windows event viewer. These codes may be driver or hardware errors that have been detected, or in many instances are simply warning or informational messages for the user.

Most events that the QLogic drivers log are event 11 codes. To decipher what these event 11 codes mean, please visit the QLogic support site for their *Guide to Interpreting Windows Event Viewer Entries* at

http://support.qlogic.com/support/logs/event_log.asp

Third-Party Software

This appendix contains additional information about third-party software used with Windows hosts.

- ◆ QLogic SANsurfer SANblade Manager 196

QLogic SANsurfer SANblade Manager

EMC has approved the use of a specialized version of the QLogic SANsurfer SANblade Manager for use with attached EMC Symmetrix, VNX series, or CLARiiON storage systems. Only the versions listed below should be used; these versions are posted in the EMC section on the QLogic website.

This Windows utility provides information on the installed QLogic adapters, driver versions, mapped targets, statistics, and configuration settings. It also has a feature to update the adapter firmware/BIOS and NVRAM. (You should obtain the latest EMC-approved firmware/BIOS and NVRAM files from the QLogic website. Refer to [“Downloading latest QLogic drivers/firmware/BIOS files”](#) on page 16 for instructions.)

For information on the use and features of the QLogic SANsurfer SANblade Manager utility, refer to the documentation posted with this utility.