

# Dell EMC Data Domain<sup>®</sup> ES30 Expansion Shelf and FS15 SSD Shelf

## Hardware Guide

302-002-104

REV. 04

Copyright © 2013-2017 EMC Corporation All rights reserved.

Published June 2017

Dell believes the information in this publication is accurate as of its publication date. The information is subject to change without notice.

THE INFORMATION IN THIS PUBLICATION IS PROVIDED "AS-IS." DELL MAKES NO REPRESENTATIONS OR WARRANTIES OF ANY KIND WITH RESPECT TO THE INFORMATION IN THIS PUBLICATION, AND SPECIFICALLY DISCLAIMS IMPLIED WARRANTIES OF MERCHANTABILITY OR FITNESS FOR A PARTICULAR PURPOSE. USE, COPYING, AND DISTRIBUTION OF ANY DELL SOFTWARE DESCRIBED IN THIS PUBLICATION REQUIRES AN APPLICABLE SOFTWARE LICENSE.

Dell, EMC, and other trademarks are trademarks of Dell Inc. or its subsidiaries. Other trademarks may be the property of their respective owners.  
Published in the USA.

Dell EMC  
Hopkinton, Massachusetts 01748-9103  
1-508-435-1000 In North America 1-866-464-7381  
[www.DellEMC.com](http://www.DellEMC.com)

# CONTENTS

	<b>Preface</b>	<b>5</b>
	<b>Revision history</b>	<b>7</b>
<b>Chapter 1</b>	<b>Shelf Installation Overview</b>	<b>9</b>
	Site requirements.....	10
	Licensing.....	10
	ES30 and FS15 chassis.....	11
	Front panel: Disks.....	11
	Back panel: Power/cooling module and shelf controllers.....	13
<b>Chapter 2</b>	<b>Installing the Shelves</b>	<b>17</b>
	Expansion shelf cables.....	18
	Safety requirements.....	20
	Racking and cabling.....	20
	Avamar integrated with Data Domain systems.....	21
	Rail kit.....	21
	Shelf cabling rules and guidelines.....	21
	Installing or adding ES30 and FS15 shelves.....	28
	Ports.....	28
	Cabling shelves.....	28
	Requirements for combining ES20s and ES30s.....	33
	DD880 cabling.....	33
	DD860 and DD890 system cabling.....	34
	DD990 cabling.....	35
	DD2500 cabling.....	42
	DD4200, DD4500, and DD7200 cabling.....	44
	DD6300, DD6800, and DD9300 cabling.....	61
	DD9500 and DD9800 cabling.....	66
	Connecting power.....	73
	Attaching the power supplies.....	73
	Types of cabinets and power connections.....	74
	Single phase power connections for 40U-P (current racks).....	75
	Single phase power connections for 40U-C (older racks).....	83
	3-Phase power connections for 40U-P (current racks).....	87
	3-Phase power connections for 40U-C (older racks).....	106
<b>Chapter 3</b>	<b>Data Domain-Specific Installation</b>	<b>111</b>
	DD640, DD670, DD860, and DD890 systems.....	112
	DD660 and DD690 systems.....	112
	DD880 systems.....	113
	DD990 systems.....	113
	DD2500 systems.....	114
	DD4200, DD4500, and DD7200 systems.....	114
	DD6300, DD6800 and DD9300 systems.....	115
	DD9500 and DD9800 systems.....	117
	I/O module slot assignments.....	117

<b>Chapter 4</b>	<b>Post-Installation Tasks</b>	<b>119</b>
	Add shelf capacity licenses.....	120
	Add storage license.....	120
	Power on sequence.....	121
	Connect power to shelves .....	121
	Verifying shelf installation.....	123
	Add enclosure disks to the volume.....	126
<b>Appendix A</b>	<b>Hardware Specifications</b>	<b>129</b>
	ES30 and FS15 hardware specifications.....	130

# Preface

Contact your Data Domain technical support professional if a product does not function properly or does not function as described in this document.

---

## Note

This document was accurate at publication time. Go to the Online Support site, <https://support.emc.com/>, to ensure that you are using the latest version of this document.

---

## Purpose

This guide describes the steps to install and configure an Data Domain ES30 Expansion Shelf.

## Audience

This guide is for trained service personnel who are authorized to install and repair Data Domain systems.

## Related documentation

The following Data Domain system documents provide additional information:

---

## Note

Look for the documents matching the Data Domain Operating System release being used in your environment.

---

- *Data Domain Operating System Release Notes*
- *Data Domain Operating System Initial Configuration Guide*
- *Data Domain Operating System Administration Guide*
- *Data Domain Operating System Command Reference Guide*
- The Data Domain system installation and setup guides for each of the supported platforms (for example, DD4500)
- For Data Domain Systems that have ES20 shelves installed: *ES20 Expansion Shelf Hardware Guide*.
- *Data Domain System Safety and Regulatory Information* (P/N 770-0002-0002)

## ES30 Field Replaceable Unit (FRU) documents

*ES30 and FS15 Expansion Shelf Field Replacement Unit Guide*.

## Special notice conventions used in this document

Data Domain uses the following conventions for special notices:



**Indicates a hazardous situation which, if not avoided, could result in death or serious injury.**

---

**CAUTION**

Indicates a hazardous situation which, if not avoided, could result in minor or moderate injury.

---

**NOTICE**

Addresses practices not related to personal injury.

---

**Note**

Presents information that is important, but not hazard-related.

---

**Typographical conventions**

Data Domain uses the following type style conventions in this document:

<b>Bold</b>	Use for names of interface elements, such as names of windows, dialog boxes, buttons, fields, tab names, key names, and menu paths (what the user specifically selects or clicks)
<i>Italic</i>	Use for full titles of publications referenced in text
Monospace	Use for: <ul style="list-style-type: none"><li>• System code</li><li>• System output, such as an error message or script</li><li>• Pathnames, filenames, prompts, and syntax</li><li>• Commands and options</li></ul>
<i>Monospace italic</i>	Use for variables
<b>Monospace bold</b>	Use for user input
[ ]	Square brackets enclose optional values
	Vertical bar indicates alternate selections - the bar means “or”
{ }	Braces enclose content that the user must specify, such as x or y or z
...	Ellipses indicate nonessential information omitted from the example

---

**Technical support**

To resolve issues with Data Domain products, contact your contracted support provider or visit us online at <https://support.emc.com/>.

**Your comments**

Your suggestions will help us continue to improve the accuracy, organization, and overall quality of the user publications. Send your opinions of this document to [DPAD.Doc.Feedback@emc.com](mailto:DPAD.Doc.Feedback@emc.com).

# Revision history

**Table 1** Document revision history

<b>Revision</b>	<b>Date</b>	<b>Document part number/ Revision number</b>	<b>Software version</b>	<b>Description</b>
04	June 2017	302-000-104 Rev. 04	6.1	Editorial revisions
03	October 2016	302-000-104 Rev. 03	6.0	New title, topics, and cabling diagrams as they relate to supporting the FS15 shelf and the DD6300, DD6800 and DD9300, and DD9800 systems
02	March 2016	302-000-104 Rev. 02	5.7.1	Support for DD OS High Availability (HA)
01	July 2015	302-000-104 Rev. 01	5.7	<ul style="list-style-type: none"><li>• Support 4TB drives on DD4500, DD7200, and DD9500 systems</li><li>• End of support of DD660, DD690, and DD880 systems</li></ul>
This document was first published in July 2011 with a different part number.				





# CHAPTER 1

## Shelf Installation Overview

### ES30 expansion shelves

Adding ES30 expansion shelves to an Data Domain system increases the system's storage capacity. The expansion shelves are organized by sets (or chains). For regular DD systems, a set consists of one to four shelves of the same model (either all ES20 or all ES30 shelves). For DD systems with the Extended Retention software option, a set consists of one to seven shelves of the same model (either all ES20 or all ES30 shelves). For redundancy, a shelf set is usually connected to two separate SAS I/O modules or HBA cards on the Data Domain controller, and all of the shelves within a set are connected to each other via dual paths.

### FS15 SSD shelf

The FS15 shelf consists of a number of SSD drives, and while the shelf chassis is the same chassis used in all ES30 products, it can only be used with DD6300, DD6800 and DD9300, and DD9500 and DD9800 systems configured with DD OS 6.0 and later.

---

#### Note

- Data Domain systems that support the ES30 shelves must be running DD OS 5.1 and later.
- For instructions on replacing one of the field replaceable components, see the appropriate ES30 Field Replaceable Unit (FRU) documentation on the Data Domain Support site. You should assume that any printed copy might be out-of-date. Therefore, always check the on-line support portal for the latest version of a FRU document before replacing any part.
- Racks are filled from the bottom up.
- For details about the SATA and SAS shelves and recommendations for the supported DD OS software and Data Domain systems, see [Shelf cabling rules and guidelines](#) on page 21.
- SSDs in an FS15 shelf are not RAID-protected.

---

This chapter covers the following major topics:

- [Site requirements](#)..... 10
- [Licensing](#)..... 10
- [ES30 and FS15 chassis](#)..... 11

## Site requirements

This table lists the ES30 and FS15 site requirements. See [ES30 and FS15 hardware specifications](#) on page 130 for hardware specifications information.

**Table 2** ES30 and FS15 site requirements

Requirement	ES30 expansion shelf
Vertical Space in Standard 19", 4-post Rack	3U. Do not use a two-post rack. See the slide rail and installation documentation in the packaging for installing in a rack.
Air Conditioning	Air conditioning that can cope with the maximum BTU/hr thermal rating.
Temperature Controls	Adequate temperature control with a gradient (change) not to exceed 30° C in an hour.
Front Bezel Clearance	1.56 inches (4.0 cm) of unobstructed clearance.
Back Panel Clearance	5 inches (12.7 cm) of unobstructed clearance.
Airflow	In a closed or multi-unit rack, ensure that the unit has adequate airflow. If the equipment is mounted in an enclosed (as opposed to a four-post open rack), the front and rear doors should have 65% minimum open area for airflow. Whether in an open or enclosed rack, use filler panels to prevent hot air recirculation. The rack design and installation should take into consideration the maximum ambient operating temperature of the equipment, which is 35° C.
Power/ Grounding	Two single-phase AC power outlets with an earth ground conductor (safety ground). A safe electrical earth connection must be provided to each power cord. Voltage should be 100-120 VAC or 200-240 VAC; 50 or 60 Hz. Use only with branch circuits protected by a minimum 15A overcurrent protector. Plug the two power cords into separate branch circuit supplies for redundancy.

## Licensing

The appropriate capacity license is required for any added shelf. There are four tiers of storage—active, archive, cache, and cloud. A license is purchased and applied to one of these tiers.

---

### Note

Only Data Domain Extended Retention (ER) systems have archive tier storage.

---

### Note

Only Data Domain DD6300, DD6800 and DD9300 systems configured with SSDs or those systems configured with a FS15 shelf have cache tier storage.

---

---

**Note**

Only Data Domain DD990, DD4200, DD4500, DD6800, DD7200, DD9300, DD9500, and DD9800 support cloud tier storage. Cloud tier storage requires the installation of ES30 shelves to store the cloud tier metadata.

---

An Expanded-Storage license is required to expand the active tier storage above the amount originally installed. You cannot use additional storage without first applying the appropriate licenses.

Additional licensing information is available in the *Data Domain Operating System Administration Guide* and the *Data Domain Operating System Command Reference Guide*.

## ES30 and FS15 chassis

This section describes the front and back panel of the ES30 and FS15 shelves and the status lights visible from the front and rear of the ES30 and FS15 chassis.

---

**Note**

Unless otherwise noted, any ES30 reference also applies to the FS15; the only differences between the two shelves are the type and quantity of drives.

---

### Front panel: Disks

After you unlock and remove the snap-on bezel on the front panel, the 15 disks are visible. Disk numbers, as reported by system commands, range from 1 to 15. When facing the front panel, Disk 1 is located in the leftmost slot in the enclosure and Disk 15 in the rightmost slot.

**Figure 1** ES30 front panel (bezel removed)



---

**Note**

The flanges or sheet metal on the ES30 show 0 to 14 but the software will refer to the logical numbering of 1 to 15.

---

Each disk in the enclosure has two LEDs. The disk's active LED glows green when the disk is functional. The disk fault LED glows amber when the disk has failed.

If there is a problem with the enclosure, the enclosure fault light is amber. The disk enclosure power light should be on (blue) when the shelf is powered on.

When replacing ES30 disks, a good practice is to run this command:

```
disk beacon <enclosure-id>.<disk-id>
```

---

**Note**

The `disk beacon` command causes the LED that signals normal operation to flash on the target disk. Enter `Ctrl-C` to stop the flash. You can also use the `enclosure beacon` command to check the LED to blink on every disk.

**Figure 2** Front panel LEDs

1. Disk enclosure fault light
2. Disk enclosure power light
3. Disk active light
4. Disk fault light

**Table 3** Status lights visible from front of disk enclosure

Light	Quantity	Color	Meaning
Disk enclosure fault light	1	Amber	On when any fault condition exists; if the fault is not obvious from a disk module light, look at the back of the disk enclosure.
Disk enclosure power light	1	Blue	Power to enclosure is on.
Disk active light	1 per disk module	Green	No LED when the slot is empty or has a filler module. Also, off when the disk is powered down by command; for example, the result of a temperature fault. Fast blinking when the SATA/SAS drive is powered up but not spinning; this is a normal part of the spin-up sequence, occurring during the spin-up delays of a slot. On when the drive has power but is not handling any I/O activity (the ready state). Slow blinking when the drive is spinning and handling I/O activity.

**Table 3** Status lights visible from front of disk enclosure (continued)

Light	Quantity	Color	Meaning
Disk fault light	1 per disk module	Amber	On when the disk module is faulty, or as an indication to replace the drive.

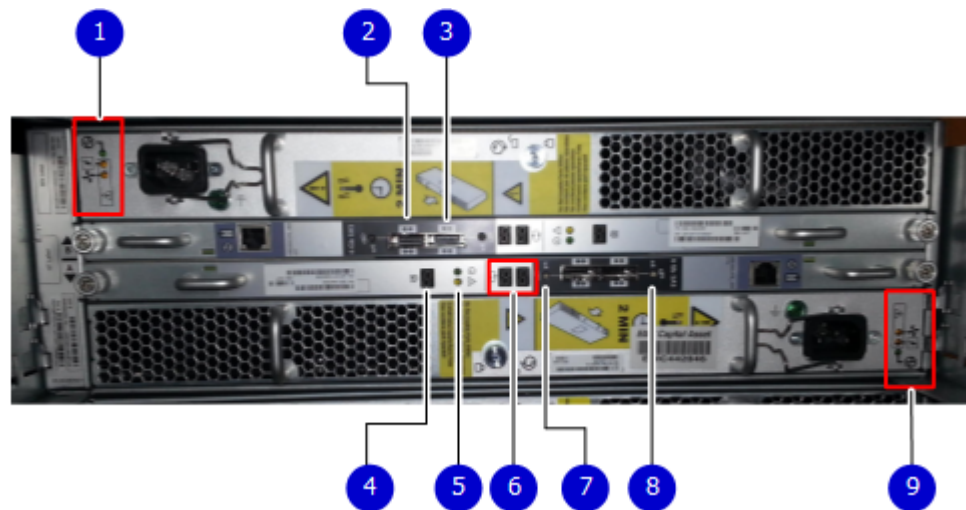
## Back panel: Power/cooling module and shelf controllers

For redundancy, the ES30 and FS15 have two identical power supply/cooling modules and two identical shelf controllers which are placed in reverse order.

### Note

When replacing a component, note its orientation before removing it. Insert the replacement in the same position.

Power supply A and controller A are located at the bottom of the chassis, and power supply B and controller B are located at the top of the chassis.

**Figure 3** Back panel: Power modules and controllers

1. LEDs
  - Power supply B: Power LED
  - Power fault: Amber
  - Blower fault: Amber
2. Expansion (Out)
3. Host (In)
4. Enclosure address (not used)
5. Power (Green) or Fault (Amber)
6. Bus ID (not used)
7. Host link active
8. Expansion link active
9. LEDs

- Power supply A Power LED
- Power fault: Amber
- Blower fault: Amber

**Figure 4** Power Supply A LEDs



Each shelf controller has two SAS ports. The port labeled with a circle symbol is the Host port, and the port labeled with a diamond symbol is the Expansion port. The Expansion ports are located on the outside, and the Host ports on the inside (reversed controller positions).

**Table 4** Status lights visible from rear of disk enclosure

Light	Quantity	Color	Meaning
Controller Power	1 per Controller	Blue or Green	On when the Controller is powered on.
Controller Fault	1 per Controller	Amber	On when either the Controller or a SAS connection is faulty. On during power-on self-test
Host Link Active	1 per Controller	Blue	On when the host connection is active.
Expansion Link Active	1 per Controller	Blue	On when the expansion connection is active.
Power Supply Active	1 per power supply	Green	On when the power supply is operating.
Power Supply Fault*	1 per power supply	Amber	On when the power supply is faulty or is not receiving AC line voltage. Flashing when either a multiple blower or ambient over temperature condition has shut off DC power to the system.
Blower Fault*	1 per power supply	Amber	On when one of the blowers in the power supply is faulty.

\*The ES30 and FS15 continue to run with a single power supply and three of its four blowers. Removing a power/cooling module constitutes a multiple blower fault

condition, and powers down the ES30 and FS15 unless you replace a module within two minutes.





# CHAPTER 2

## Installing the Shelves

This chapter covers the following major topics:

- [Expansion shelf cables](#)..... 18
- [Safety requirements](#)..... 20
- [Racking and cabling](#)..... 20
- [Avamar integrated with Data Domain systems](#)..... 21
- [Rail kit](#)..... 21
- [Shelf cabling rules and guidelines](#)..... 21
- [Installing or adding ES30 and FS15 shelves](#)..... 28
- [Requirements for combining ES20s and ES30s](#)..... 33
- [Connecting power](#)..... 73
- [Types of cabinets and power connections](#)..... 74

## Expansion shelf cables

Expansion shelves are connected to each other and to the Data Domain controller with qualified cables. The expansion shelf can be connected to supported Data Domain systems only by using SAS (serial-attached SCSI) cables. Only a fully populated Data Domain shelf with qualified disks can be added as an expansion shelf.

---

### Note

Shelves for other Dell EMC product lines look identical. Check the product numbers when unpacking.

---

### ES30 cables

There are two different types of ES30 cables. One type of cable has the same type of connector at both ends and is used to connect ES30s to each other or to connect ES30s to controllers with SAS HBAs. DD990 and DD670 are examples of those controllers. The other type of cable has a different connector on one end and is used to connect ES30s to controllers that have SAS I/O Modules. DD2500, DD4200, DD6300, DD6800, DD7200, DD9300, DD9500, and DD9800 systems are examples of controllers with the SAS I/O Modules.

The connector on the ES30 is called—mini-SAS. The I/O Module connector is called—HD-mini-SAS. The cables with HD-mini-SAS at one end are available in 2M, 3M, and 5M lengths.

The available ES30 cables with mini-SAS connectors at both ends are 1M, 2M, 3M and 5M in length.

---

### Note

- The mini-SAS connectors are keyed and labeled with an identifying symbol. Host port is identifier with ● symbol and Expander (Expansion) port with ◆ symbol.
  - The end that is marked with the circle symbol connects to the ES30 controller port marked with a circle.
  - The connector end that is marked with a diamond attaches either to a host SAS HBA port, or to an ES30 controller port marked with a diamond symbol.
- 

Use the appropriate length for the connection you are making. Refer to the specific Installation and Configuration Guide for recommended cable lengths. For example, you might:

- Use the 2-meter host-to-shelf cables to connect a Data Domain controller to the top or bottom shelf in a shelf set when the host and shelves are in the same rack.
- Use a 3-meter or 5-meter cable to connect a controller-to-shelves when the shelves are not located in the same rack as the host.
- Use the 1-meter shelf-to-shelf cables to connect shelves to other shelves within a shelf set in the same rack. Use a 2-meter, 3-meter, or 5-meter cable to connect shelves to other shelves when the set spans racks.

**Table 5** Mini-SAS to Mini-SAS cable part numbers

Cable part number	Cable length
038-003-786	1 m. (39 in.)
038-003-787	2 m. (79 in.)
038-003-751	3 m. (118 in.)
038-003-666	5 m. (196 in.)

**Table 6** HD-Mini-SAS to Mini-SAS cable part numbers

Cable part number	Cable length
038-003-810	2 m. (79 in.)
038-003-811	3 m. (118 in.)
038-003-813	5 m. (196 in.)

**Table 7** HA HD-Mini-SAS to Mini-SAS cable part numbers (node 1)

Cable part number	Cable length
038-004-108	2 m. (79 in.)
038-004-111	5 m. (196 in.)

The cable connectors must be secured with their latch assembly.

### ES20 cables

#### Note

ES20 shelves are only supported on DD6300, DD6800 and DD9300, and DD9500 and DD9800 systems on a temporary basis when migrating storage from the ES20 shelves to ES30 shelves.

The following cables are available for the ES20 connections. See the *Data Domain ES20 Hardware Guide* for more information.

- Data Domain controller to ES20 shelves: 1M, 2M, and 5M.
- ES20 to ES20 shelves: 0.5M, 1M, 2M, and 5M.

**Table 8** ES20 HD-Mini-SAS cable part numbers (for DD4200, DD4500, DD7200, and DD9500 systems)

Cable part number	Cable length
X-SAS-HDIB2	2 m. (79 in.)
X-SAS-HDIB5	5 m. (196 in.)

#### Note

Cables for the ES20 are different than the cables for the ES30.

## Safety requirements

**⚠ WARNING**

**The rack or cabinet should be securely bolted to the floor for personnel safety; if not, it could tip over. If securing the rack to the floor is not feasible, and you have less than a fully populated configuration, for personnel safety you must ensure a low center of gravity.**

---

The following safety requirements must be considered when the unit is mounted in a rack.

- Ensure that the site requirements have been met. Review the [Site requirements](#) on page 10.
- The rack design should incorporate stabilizing features suitable to prevent the rack from tipping or being pushed over during installation or in normal use.
- When loading a rack with the units, fill the rack from the bottom up and empty the rack from the top down.
- All products in the rack must have front-to-back cooling to prevent air recirculation.
- The rack should have a safe electrical distribution system. It must provide overcurrent protection for the unit and must not be overloaded by the total number of units installed in the rack. Consideration of the electrical power consumption rating shown on the nameplate should be used when addressing these concerns. For more information see [Connecting power](#) on page 73.

## Racking and cabling

The shelves are 3U and the Data Domain controller is either 2U or 4U. For more information, see your Data Domain system hardware overview.

Data Domain has adopted recommended racking guidelines. The guidelines for some systems differ slightly from their specific Data Domain Extended Retention System options (see the figures later in this section).

To provide the best trade-off in terms of serviceability, system expansion, and cabling, mount the Data Domain controller starting above the first set of shelves in the rack—usually 13U for most systems.

---

**Note**

Racks are filled from the bottom up.

---

**Note**

When a 2U controller is mounted in a 4U gap between controllers, it can be mounted in any of the 3 positions in that gap.

---

You can connect the 2-meter cable attached to the Data Domain controller to any shelf in the same rack. You can extend the ES30's one-meter shelf-to-shelf cable from an ES30 located in position 1 of the shelf set to an ES30 in position 3 of the set and still conform to cabling recommendations. As shown in [Figure 7](#) on page 32, shelf 1 is the bottom shelf of a set and shelf 3 is the top shelf in a set of three. Install filler panels in unused rack openings.

There are figures showing the various configurations through the remainder of this document. These are guidelines. Other sections define the rules for different systems. All rules must be followed but using a recommended configuration may depend on other restrictions in a specific installation.

After your hardware is installed, route and organize ES30 cables by affixing them to the side of the rack to facilitate servicing.

Although you can plan for growth by leaving empty positions in the rack, this method is safe only if the rack is securely bolted to the floor, or if the resulting configuration has a low center of gravity. When in doubt, do not leave empty spaces, and populate based on the guidelines in this section.

## Avamar integrated with Data Domain systems

Integrated Avamar Data Domain solutions are possible for older systems. Figures are provided showing how these are racked and cabled. The recommended configuration has the Avamar node in Rack 1 at position U39 in the rack. 10U of space below the node are left free for Avamar expansion. The ES30 shelves occupying those positions must be moved; thus the cabling may be very different than a standard configuration.

---

### Note

Avamar is not integrated with the DD6300, DD6800 and DD9300, and DD9500 and DD9800 systems.

---

## Rail kit

One of each of these items is included with each ES30 shelf.

**Table 9** ES30 rail kit

Rail kit	Rack depth
Slide Rail Kit, ES30	20.5-34 inches (52-86.4 cm)
Rail Adapter Kit	Supports racks to a depth of 36 inches (91.4 cm) and supports racks with threaded holes. See the document <i>ES30 Rail Install</i> .

---

### Note

- Systems that are delivered in racks use a slightly different Rail Kit and do not need the Rail Adapter Kit.
- 

## Shelf cabling rules and guidelines

The Data Domain system re-discovers newly configured shelves after it restarts. You can power down the system and re-cable shelves to any other position in a set, or to another set. To take advantage of this flexibility, these rules **MUST** be followed before making any cabling changes:

- Do not exceed the maximum shelf configuration values for your Data Domain system as listed in the table below.

- Do not mix ES30s and ES20s in the same set. A set is the group of shelves connected together and to the same Data Domain system's controller ports.
- Do not mix SAS-based ES30 shelves with any other shelf type in the same set.
- For redundancy, the two connections from a Data Domain system to a set of shelves must use ports on different SAS HBAs or SAS I/O modules. The DD2500 and DD6300 systems are an exception to this rule.
- Use the Installation and Configuration Guide for your controller to minimize the chance of a cabling mistake.
- A Data Domain system cannot exceed its maximum raw external shelf capacity, regardless of added shelf capacity.
- When used, a FS15 shelf does not count against the capacity total but it is counted for shelf limits.

---

**Note**

- ES30-45 SATA shelves must be running DD OS 5.4 and later and are only supported on the DD990, DD4200, DD4500, DD6300, DD6800, DD7200, DD9300, DD9500, and DD9800 systems.
  - ES30 SAS shelves must be running DD OS 5.4 and later and are only supported on DD2500, DD4200, DD4500, DD6300, DD6800, DD7200, DD9300, DD9500, and DD9800 systems.
  - DD OS 5.6 does not support the ES20 shelves on the DD9500 systems. However, in DD OS 5.7 and later, ES20 shelves can be attached to a DD6300, DD6800 and DD9300, or DD9500 or DD9800 system only for the period of time necessary to complete the shelf migration process.
  - DD OS 5.7 and later support 4TB drives on the DD4500, DD6300, DD6800, DD7200 (256GB), DD9300, DD9500, and DD9800 systems.
  - DD OS 5.7 and later do not support the DD660, DD690, DD880 systems.
  - ERSO systems do not support HA or DD Cloud Tier.
  - HA systems do not support SATA drives.
- 

**Table 10** Shelf configuration supported per Data Domain system

DD system	Memory required (GB)	SAS cards/port per card	ES30 support (TB)	ES20 support (TB) <sup>1</sup>	Max shelves per set	Max number of sets	Max external capacity available (TB) <sup>2</sup>	Max RAW external capacity (TB) <sup>8</sup>
DD640 <sup>3</sup>	20	2x4	15, 30	No support	1	2	24	30
DD660	16	2x2	15	8, 16	3	2	18	24
DD670	16	2x4 (Optional)	15	16	1	1	12	16
DD670	36	2x4 (Optional)	15, 30	16, 32	2	2	48	64
DD690	16	2x2	15	8, 16	2	2	24	32

**Table 10** Shelf configuration supported per Data Domain system (continued)

DD system	Memory required (GB)	SAS cards/port per card	ES30 support (TB)	ES20 support (TB) <sup>1</sup>	Max shelves per set	Max number of sets	Max external capacity available (TB) <sup>2</sup>	Max RAW external capacity (TB) <sup>8</sup>
DD690	24	2x2	15, 30	8, 16	3	2	36	48
DD860	36	2x4	15, 30	16, 32	2	4	48	64
DD860	72	2x4	15, 30	16, 32	3	4	144	192
DD860 ER <sup>4</sup>	72	3x4	15, 30	16, 32	4	6	288	384
DD880	48	2x2	15, 30	8, 16, 32	3	2	72	96
DD880 (3 SAS cards)	64	3x2	15, 30	8, 16, 32	4	3	144	192
DD890	96	2x4	15, 30	16, 32	3 with 5.0; 4 with 5.1	4	288	384
DD990	128	3x4	15, 30, 45 <sup>5</sup>	16, 32	5 <sup>6</sup>	6	288	384
DD990	256	3x4	15, 30, 45 <sup>5</sup>	16, 32	5 <sup>6</sup>	6	576	768
DD990 ER <sup>4</sup>	256	4x4	15, 30, 45 <sup>5</sup>	16, 32	7	8	1152	1536
DD990 w/ DD Cloud Tier <sup>13</sup>	256	4x4	15, 30, 45 <sup>5</sup>	16, 32	5 <sup>6</sup>	6	576 (max), additional 144 SAS dedicated to DD Cloud Tier	768 (max), additional 180 SAS dedicated to DD Cloud Tier
DD2500 <sup>3</sup>	32	—	—	—	—	—	—	—
DD2500 <sup>3</sup>	64	1x4	SAS 30, 45	No Support	4	1	108	135
DD4200 <sup>7</sup>	128	2x4	SAS 30, 45; SATA 15, 30, 45 <sup>5</sup>	16, 32	5 <sup>6</sup>	4	192	256
DD4200 ER <sup>4,7</sup>	128	4x4	SAS 30, 45; SATA 15, 30, 45 <sup>5</sup>	16, 32	7	8	384	512
DD4200 w/ DD Cloud Tier	128	3x4	SAS 30, 45; SATA 15, 30, 45 <sup>5</sup>	16, 32	7	8	192 (max), additional 72 SAS dedicated to DD Cloud Tier	256 (max), additional 90 SAS dedicated to DD Cloud Tier
DD4500	192	2x4	SAS 30, 45, 60;	16, 32	5 <sup>6</sup>	4	288	384

**Table 10** Shelf configuration supported per Data Domain system (continued)

DD system	Memory required (GB)	SAS cards/port per card	ES30 support (TB)	ES20 support (TB) <sup>1</sup>	Max shelves per set	Max number of sets	Max external capacity available (TB) <sup>2</sup>	Max RAW external capacity (TB) <sup>8</sup>
			SATA 15, 30, 45 <sup>5</sup>					
DD4500 ER <sup>4,7</sup>	192	4x4	SAS 30, 45, 60; SATA 15, 30, 45 <sup>5</sup>	16, 32	7	8	576	768
DD4500 w/ DD Cloud Tier	192	3x4	SAS 30, 45, 60; SATA 15, 30, 45 <sup>5</sup>	16, 32	7	8	288 (max), additional 96 SAS dedicated to DD Cloud Tier	384 (max), additional 120 SAS dedicated to DD Cloud Tier
DD6300 <sup>13</sup>	48	1x4 (Optional)	SAS 30, 45, 60	N/A <sup>11</sup>	1	1	48	60
DD6300 w/ Expanded Capacity <sup>12, 13</sup>	96	1x4 (Optional)	SAS 30, 45, 60	N/A <sup>11</sup>	5	1	144	180
DD6800 or DD6800w/ HA <sup>13</sup>	192	2x4	SAS 30, 45, 60; SATA 15, 30, 45 <sup>5</sup>	N/A <sup>11</sup>	7 <sup>14</sup>	4	144	180
DD6800 w/ Expanded Capacity <sup>12, 13</sup>	192	2x4	SAS 30, 45, 60; SATA 15, 30, 45 <sup>5</sup>	N/A <sup>11</sup>	7 <sup>14</sup>	4	288	360
DD6800 w/ Expanded Capacity w/ HA <sup>12, 13</sup>	192	2x4	SAS 30, 45, 60	N/A <sup>11</sup>	7 <sup>14</sup>	4	288	360
DD6800 w/ ER <sup>13</sup>	192	2x4	SAS 30, 45, 60; SATA 15, 30, 45 <sup>5</sup>	N/A <sup>11</sup>	7 <sup>14</sup>	4	576	720
DD6800 w/ DD Cloud Tier <sup>13</sup>	192	2x4	SAS 30, 45, 60; SATA 15, 30, 45 <sup>5</sup>	N/A <sup>11</sup>	7 <sup>14</sup>	4	288 (max), additional 96 SAS dedicated to DD Cloud Tier	360 (max), additional 120 SAS dedicated to DD Cloud Tier
DD6800 w/ HA and DD Cloud Tier <sup>13</sup>	192	2x4	SAS 30, 45, 60	N/A <sup>11</sup>	7 <sup>14</sup>	4	288 (max), additional 96 SAS dedicated to DD Cloud Tier	360 (max), additional 120 SAS dedicated to DD Cloud Tier



**Table 10** Shelf configuration supported per Data Domain system (continued)

DD system	Memory required (GB)	SAS cards/port per card	ES30 support (TB)	ES20 support (TB) <sup>1</sup>	Max shelves per set	Max number of sets	Max external capacity available (TB) <sup>2</sup>	Max RAW external capacity (TB) <sup>8</sup>
DD7200	128	2x4	SAS 30, 45; SATA 15, 30, 45 <sup>5</sup>	16, 32	5 <sup>6</sup>	4	192	256
DD7200	256	2x4	SAS 30, 45, 60; SATA 15, 30, 45 <sup>5</sup>	16, 32	5 <sup>6</sup>	4	384	512
DD7200 ER <sup>4,7</sup>	256	4x4	SAS 30, 45, 60; SATA 15, 30, 45 <sup>5</sup>	16, 32	7	8	768	1024
DD7200 w/ DD Cloud Tier <sup>13</sup>	256	2x4	SAS 30, 45, 60; SATA 15, 30, 45 <sup>5</sup>	16, 32	5 <sup>6</sup>	4	384 (max), additional 192 SAS dedicated to DD Cloud Tier	512 (max), additional 240 SAS dedicated to DD Cloud Tier
DD9300 <sup>13</sup>	192	2x4	SAS 30, 45, 60; SATA 15, 30, 45 <sup>5</sup>	N/A <sup>11</sup>	7 <sup>14</sup>	4	384	480
DD9300 w/ Expanded Capacity <sup>12, 13</sup>	384	2x4	SAS 30, 45, 60; SATA 15, 30, 45 <sup>5</sup>	N/A <sup>11</sup>	7 <sup>14</sup>	4	720	900
DD9300 w/ Expanded Capacity or w/ HA <sup>12, 13</sup>	384	2x4	SAS 30, 45, 60	N/A <sup>11</sup>	7 <sup>14</sup>	4	720	900
DD9300 w/ ER <sup>13</sup>	384	2x4	SAS 30, 45, 60; SATA 15, 30, 45 <sup>5</sup>	N/A <sup>11</sup>	7 <sup>14</sup>	4	1440	1800
DD9300 Expanded Capacity w/ DD Cloud Tier <sup>13</sup>	384	2x4	SAS 30, 45, 60; SATA 15, 30, 45 <sup>5</sup>	N/A <sup>11</sup>	7 <sup>14</sup>	4	720 (max), additional 192 SAS dedicated to DD Cloud Tier	900 (max), additional 240 SAS dedicated to DD Cloud Tier
DD9300 w/ Expanded Capacity or w/ HA and DD Cloud Tier <sup>12, 13</sup>	384	2x4	SAS 30, 45, 60	N/A <sup>11</sup>	7 <sup>14</sup>	4	720 (max), additional 192 SAS dedicated to DD Cloud Tier	900 (max), additional 240 SAS dedicated to DD Cloud Tier

**Table 10** Shelf configuration supported per Data Domain system (continued)

DD system	Memory required (GB)	SAS cards/port per card	ES30 support (TB)	ES20 support (TB) <sup>1</sup>	Max shelves per set	Max number of sets	Max external capacity available (TB) <sup>2</sup>	Max RAW external capacity (TB) <sup>8</sup>
DD9500	256	3x4	SAS 30, 45, 60; SATA 15, 30, 45 <sup>5</sup>	N/A <sup>11</sup>	5 <sup>6</sup>	6	432	540
DD9500	512	3x4	SAS 30, 45, 60; SATA 15, 30, 45 <sup>5</sup>	N/A <sup>11</sup>	5 <sup>6</sup>	6	864	1080
DD9500 ER <sup>4, 7</sup>	512	4x4	SAS 30, 45, 60; SATA 15, 30, 45 <sup>5</sup>	N/A <sup>11</sup>	7	8	1728	2160
DD9500 HA <sup>9, 10</sup>	256	3x4	SAS 30, 45, 60	N/A <sup>11</sup>	5 <sup>6</sup>	6	432	540
DD9500 HA <sup>9, 10</sup>	512	3x4	SAS 30, 45, 60	N/A <sup>11</sup>	5 <sup>6</sup>	6	864	1080
DD9500 w/ DD Cloud Tier <sup>13</sup>	512	4x4	SAS 30, 45, 60; SATA 15, 30, 45	N/A <sup>11</sup>	7	8	864 (max), additional 240 SAS dedicated to DD Cloud Tier	1080 (max), additional 300 SAS dedicated to DD Cloud Tier
DD9500 w/ HA and DD Cloud Tier <sup>13</sup>	512	4x4	SAS 30, 45, 60	N/A <sup>11</sup>	7	8	864 (max), additional 240 SAS dedicated to DD Cloud Tier	1080 (max), additional 300 SAS dedicated to DD Cloud Tier
DD9800 <sup>13</sup>	256	3x4	SAS 30, 45, 60; SATA 15, 30, 45	N/A <sup>11</sup>	5	6	504	630
DD9800 w/ HA <sup>13</sup>	256	3x4	SAS 30, 45, 60	N/A <sup>11</sup>	5	6	504	630
DD9800 <sup>12, 13</sup>	768	3x4	SAS 30, 45, 60; SATA 15, 30, 45	N/A <sup>11</sup>	5	6	1008	1260
DD9800 w/ HA <sup>13</sup>	768	3x4	SAS 30, 45, 60	N/A <sup>11</sup>	5	6	1008	1260
DD9800 w/ ER <sup>13</sup>	768	4x4	SAS 30, 45, 60; SATA 15, 30, 45	N/A <sup>11</sup>	7	8	2016	2520

**Table 10** Shelf configuration supported per Data Domain system (continued)

DD system	Memory required (GB)	SAS cards/port per card	ES30 support (TB)	ES20 support (TB) <sup>1</sup>	Max shelves per set	Max number of sets	Max external capacity available (TB) <sup>2</sup>	Max RAW external capacity (TB) <sup>8</sup>
DD9800 w/ DD Cloud Tier <sup>13</sup>	768	4x4	SAS 30, 45, 60; SATA 15, 30, 45	N/A <sup>11</sup>	7	8	1008 (max), additional 240 SAS dedicated to DD Cloud Tier	1260 (max), additional 300 SAS dedicated to DD Cloud Tier
DD9800 w/ HA and DD Cloud Tier <sup>13</sup>	768	4x4	SAS 30, 45, 60	N/A <sup>11</sup>	7	8	1008 (max), additional 240 SAS dedicated to DD Cloud Tier	1260 (max), additional 300 SAS dedicated to DD Cloud Tier

1. ES20 shelves are only supported on DD990, DD4200, and DD7200 systems when moved from another system, such as a head-swap upgrade.

2. This figure only counts drives that have user data in the shelves. For example an ES20-16 has 12TB and an ES30-45 has 36TB.

3. Specific configuration rules apply when supporting external storage. Please see the controller documentation for details.

4. With Extended Retention software.

5. ES30-45 (SATA) is only supported with DD OS 5.4 or later.

6. 5 shelves maximum with ES30, 4 is the recommended maximum. 4 shelves maximum with ES20, 3 is the recommended maximum.

7. The maximum shelf count for any specific drive/shelf size might be less than the product of max shelves x max shelves per set.

8. The raw capacity of an ES30 is 125% of the available capacity. The raw capacity of an ES20 is 133% of the available capacity. The calculation for maximum RAW external capacity can be between these two numbers depending on the mix of these shelves that actually are used to get to the maximum.

9. There is no support for ERSO on HA systems.

10. There is no support for HA with SATA drives.

11. ES20 shelves are only supported on DD6300, DD6800 and DD9300, and DD9500 or DD9800 systems on a temporary basis when migrating storage from the ES20 shelves to ES30 shelves.

12. DDOS 6.0 and FS15 SSD shelf configuration

13. Only available with DD OS 6.0.

14. Recommended configurations start at four shelves per set and expand beyond that as required. For HA configurations, the FS15 counts as a shelf.

---

### Note

Customers whose ER storage already exceed these limits do not have to decrease their systems to these limits. When running DD OS 5.5 or later they cannot increase their system capacity.

---

---

**Note**

1RU = 1 Retention Unit , size equal to active tier

1. If you already have more than 1 RU, you get to keep it when you upgrade to DD OS 5.5.1. But there is a caveat: you cannot use encryption or any new feature that we add after 5.5.1.
  2. You cannot configure more than 1RU per storage tier when using DD OS 5.5.1 and later.
- 

## Installing or adding ES30 and FS15 shelves

Refer to the table and related information in [Shelf cabling rules and guidelines](#) on page 21 for shelf configuration restrictions.

### Ports

Depending on the model, a Data Domain system has one to four dual- or quad-port SAS HBA cards or SAS I/O modules installed. The ES30 shelf has two controllers (B located above A). Each controller has two ports, a host and an expansion port.

See [Data Domain-Specific Installation](#) on page 111 for SAS HBA card, SAS I/O module, and port locations.

### Cabling shelves

---

**Note**

- Before cabling the shelves, physically install all shelves in the racks. Refer to the rail kit installation instructions included with the ES30 shelf for rack mounting.
  - The documentation refers to two SAS HBAs. If only one HBA is allowed in a system, then use another port as defined later for that specific system.
  - On an HA system, add cables from the second node to open ports at the end of the sets. The ports on the second node must connect to the same sets as the corresponding ports on the first node.
- 

Ports on the Data Domain system's SAS HBA cards connect directly to a shelf controller's host port. For redundancy, you need to create dual paths by using a port on one SAS HBA card to connect to one shelf controller in each shelf set, and a port on another SAS HBA card to connect to another shelf controller in the same shelf set. With dual paths, if one SAS HBA card fails, the shelf is still operational. However, in the unlikely event any single shelf becomes completely disconnected from power or SAS cables and becomes disconnected from a previously operational shelf, the file system goes down and the shelf is not operational. This is considered a double failure.

There are two kinds of configurations: one shelf in a set or multiple shelves in a set.

## Cable a set that consists of one shelf

### Procedure

1. Make a connection from one of the Data Domain system's SAS HBA ports (for example, HBA 3 Port A) to the shelf's Controller A's host port using a DD System-to-Shelf cable.
2. Make a second connection from a port on another SAS HBA card (for example, HBA 2 Port B) to the shelf Controller B's host port using a DD System-to-Shelf cable.

---

### Note

- The port to shelf cabling is different for each controller. Cabling details such as HBA port numbers can be found in the system's installation and configuration guide.
  - If only one HBA is allowed in a system (such as for the DD2500 system), then use another port as defined for that specific system.
- 

## Cable a set that contains multiple shelves

### Procedure

1. Connect one SAS HBA port (for example, HBA 3 Port A) on the Data Domain system to the top shelf controller's host port, using a DD System-to-Shelf cable.
2. Using another HBA card (for example, HBA 2 Port B), connect a SAS port to the bottom shelf controller's host port, using a DD System-to-Shelf cable.
  - Whenever you add a shelf to an existing set, remove the SAS HBA cable and re-connect it to the current top/bottom shelf. The SAS HBA cables are always connected to the top and bottom shelves in the set. Add shelves in the installation order for your controller.
  - If only one HBA is allowed in a system (such as for the DD2500 system), then use another port as defined for that specific system.

Figure 5 Shelf cabling connections

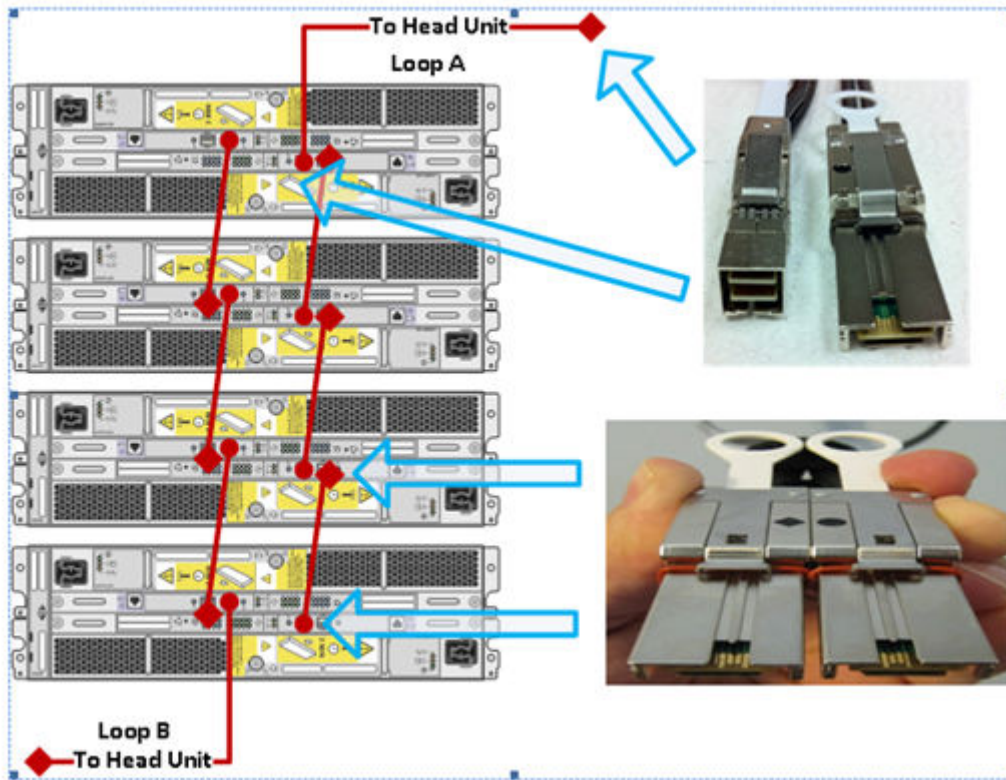
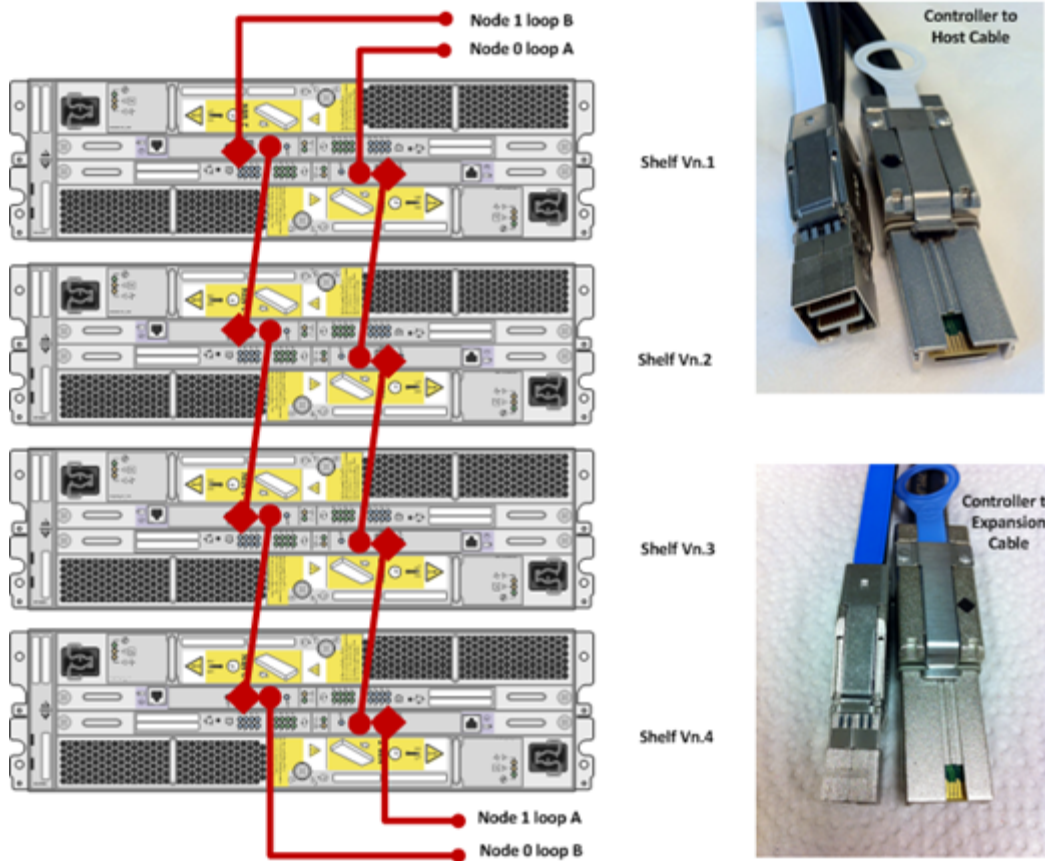


Figure 6 HA shelf cabling connections



**Note**

SAS HBA Card 3 is installed above SAS HBA Card 2 when the HBA is mounted horizontally. The ports are labeled D, C, B, and A (as viewed facing the rear panel of the Data Domain system when the HBA is mounted vertically). Cabling for each port is represented by a different color.

- For the DD860 or DD890 systems, follow the recommended port connections given in the following tables.

**Table 11** SAS HBA Card 3: recommended port connections (DD860/DD890 systems)

Port D	Port C	Port B	Port A
Bottom of set 4	Top of set 3	Bottom of set 2	Top of set 1

**Table 12** SAS HBA Card 2: recommended port connections (DD860/DD890 systems)

Port D	Port C	Port B	Port A
Bottom of set 3	Top of set 4	Bottom of set 1	Top of set 2

- Connect the shelves within a set by cabling expansion-to-host ports. To duplicate paths, always connect A controllers to A controllers and B controllers to B controllers. Use the shelf-to-shelf cables.

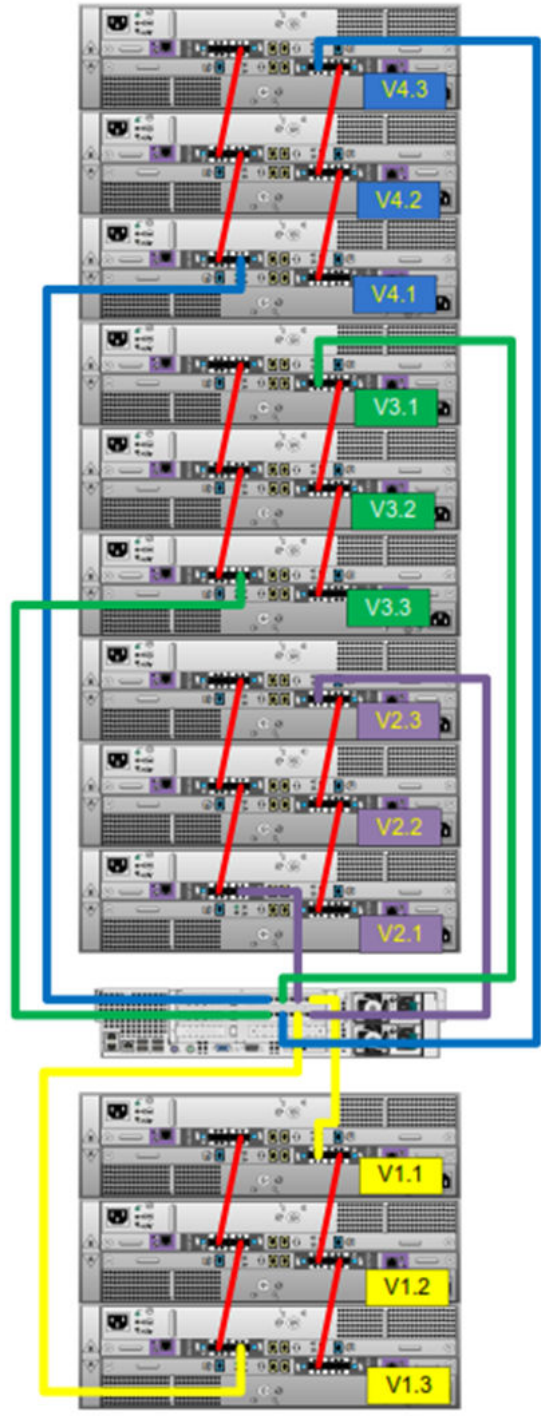
---

**Note**

For redundancy, always cable Shelf Controller A to Shelf Controller A, and Shelf Controller B to Shelf Controller B to create independent duplicate the paths.

---

**Figure 7** Shelf set connection overview





## Requirements for combining ES20s and ES30s

Refer to the table and associated information in [Shelf cabling rules and guidelines](#) on page 21 for shelf configuration restrictions.

See the cabling instructions that apply to your Data Domain system:

---

### Note

DD OS 5.7 and later releases do not support the DD660, DD690, DD880 systems.

---

- [Data Domain Extended Retention for DD860 systems](#) on page 35
- [DD880 cabling](#) on page 33
- [DD860 and DD890 system cabling](#) on page 34
- [DD990 cabling](#) on page 35
- [DD2500 cabling](#) on page 42
- [DD4200, DD4500, and DD7200 cabling](#) on page 44
- [DD6300, DD6800 and DD9300 cabling](#)
- [DD9500 and DD9800 cabling](#)

For HA pairs, the primary and standby nodes use different cables to connect to ES30/FS15 shelves. The primary node uses ES30/FS15 HOST (circle) connections, and the standby node uses ES30/FS15 EXPANSION (diamond) connections.

---

### Note

- A shelf set must consist of either all ES20s or all ES30 shelves. These two models cannot be mixed in the same shelf set.
  - DD660 and DD690 support only two sets, so if both ES20s and ES30s are used, there is one set of each.
  - The figures contain suggested cabling for Data Domain systems integrated with Avamar.
- 

## DD880 cabling

---

### Note

DD OS 5.7 and later releases do not support the DD880 systems.

---

The DD880 with two dual-port SAS cards supports two sets with a maximum of three shelves per set. The DD880 with three dual-port SAS cards supports three sets with a maximum of four shelves per set.

### Procedure

1. Free up the minimum number of sets to hold the number of ES30s to be added. For example, to add two ES30s, free up one set by placing all of the ES20s into two sets. To add five ES30s, two sets must be freed by placing all of the ES20s into one set.
2. Distribute ES20 or ES30 evenly across their respective sets.

## DD860 and DD890 system cabling

After you determine the number of each model of shelf to be used, plan your racking based on the appropriate configuration shown below. For example, if you have two ES20s and three ES30s, use Configuration A below. Distribute or re-distribute the shelves across the sets as shown for your configuration. The goal is to distribute the shelves as equally as possible.

### Note

The tables show the HBA ports used to connect each set to the Data Domain controller.

**Table 13** Configuration A: 1-to-6 ES20 and 1-to-6 ES30 shelves

1-6 ES20s		1-6 ES30s	
HBA Ports 3a-2b	HBA Ports 2a-3b	HBA Ports 3c-2d	HBA Ports 2c-3d
ES20	ES20	ES30	ES30
ES20	ES20	ES30	ES30
ES20	ES20	ES30	ES30

**Table 14** Configuration B: 7-to-9 ES20 and 1-to-3 ES30 shelves

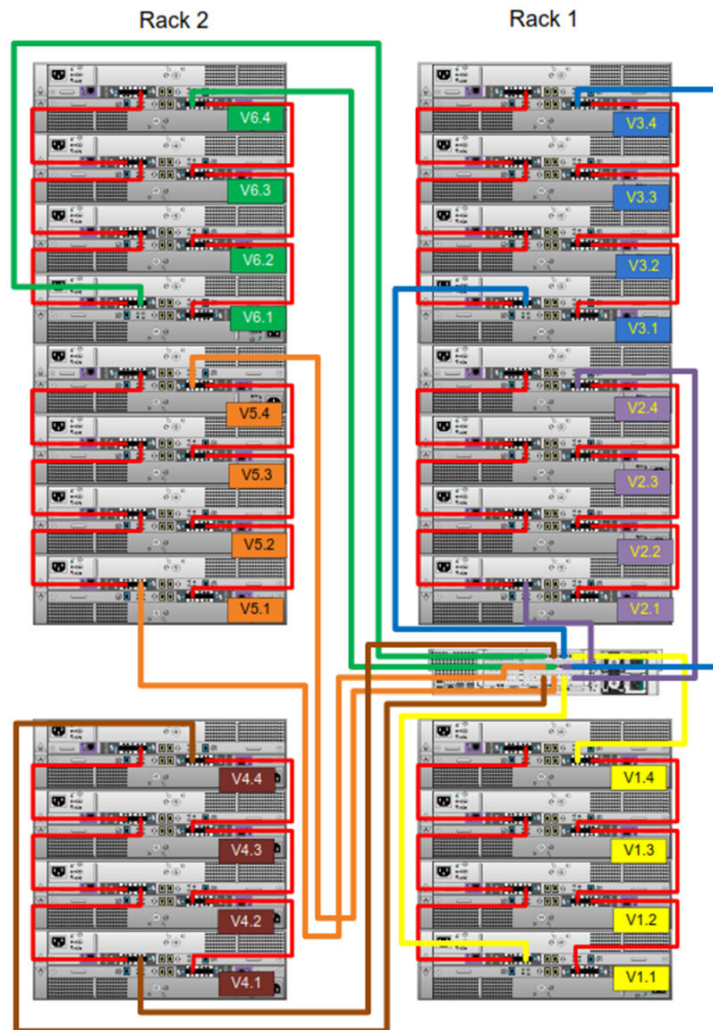
7-9 ES20s			1-3 ES30s
HBA Ports 3a-2b	HBA Ports 2a-3b	HBA Ports 3c-2d	HBA Ports 2c-3d
ES20	ES20	ES20	ES30
ES20	ES20	ES20	ES30
ES20	ES20	ES20	ES30

**Table 15** Configuration C: 1-to-3 ES20 and 7-to-9 ES30 shelves

1-3 ES20s	7-9 ES30s		
HBA Ports 3a-2b	HBA Ports 2a-3b	HBA Ports 3c-2d	HBA Ports 2c-3d
ES20	ES30	ES30	ES30
ES20	ES30	ES30	ES30
ES20	ES30	ES30	ES30

When there are seven shelves of one type, to minimize re-cabling, configure them as 3-3-1, two sets of three shelves and a fourth set of one. A 3-2-2 configuration is also acceptable.

DD OS 5.1 and later support four shelves per sets for the DD860 and DD890 systems. The additional shelves per set provide flexibility for ES20/ES30 configurations and for combining shelves with 1 TB or 2 TB drives. When adding shelves to a DD860 or DD890, you have the option of adding a fourth shelf to any set of the same type.

**Figure 8** Recommended cabling for an extended retention system for DD860

## Data Domain Extended Retention for DD860 systems

Data Domain Extended Retention systems for DD860 have three quad-port SAS cards and support six sets with a maximum of four shelves per set.

### Note

As mentioned, you cannot combine ES20 and ES30 shelves in the same set.

## DD990 cabling

There are a few rules that must be followed when adding both ES20 and ES30 shelves to a DD990 system.

- You can have a minimum of four shelves for a DD990 system with or without the Extended Retention software.
- You cannot exceed the maximum amount of raw capacity listed in [Table 16](#) on page 40 below. (For this calculation, ES20s can be counted as either 15 or 30 TB to match the raw capacity of ES30s.)

- You cannot exceed the maximum number of shelves listed.
- You cannot have more than four ES20s in one set. The recommendation is three.
- You cannot have more than five ES30s one set. The recommendation is four.
- The power requirements for ES20s are greater than for ES30s. Ensure sufficient redundant power in the rack.
- There are no specific placement or cabling requirements for the metadata shelves for DD Cloud Tier configurations. These shelves can be installed and cabled the same way as standard ES30 shelves.

**Note**

In expansion beyond 24 shelves when using the cable kits, it may be necessary to swap cables.

**Figure 9** Recommended DD990 cabling

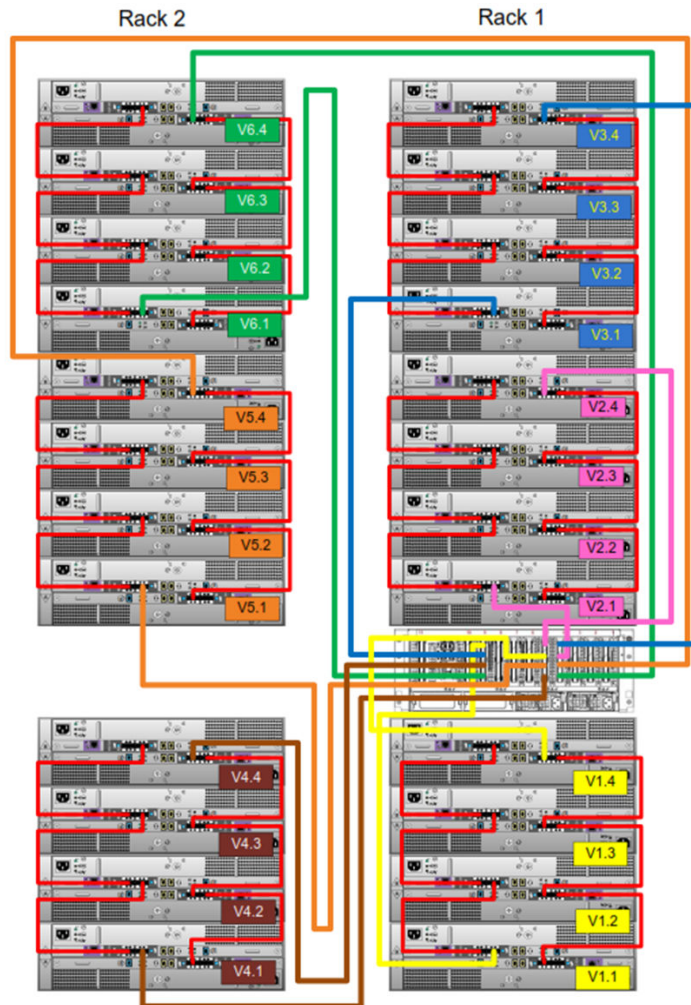
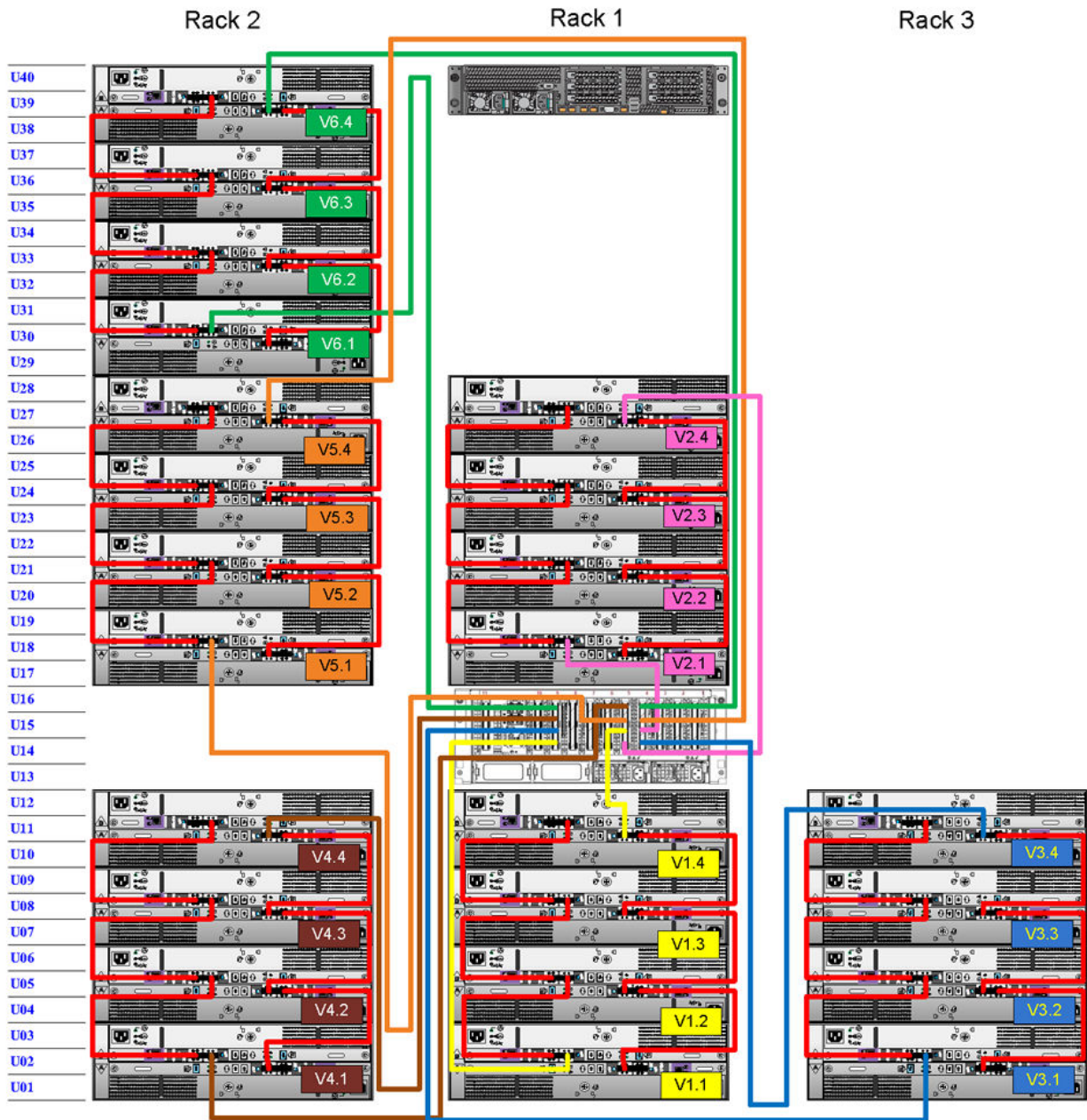


Figure 10 Recommended cabling for DD990 integrated with Avamar



**Figure 11** Recommended cabling for an extended retention or DD Cloud Tier system for DD990

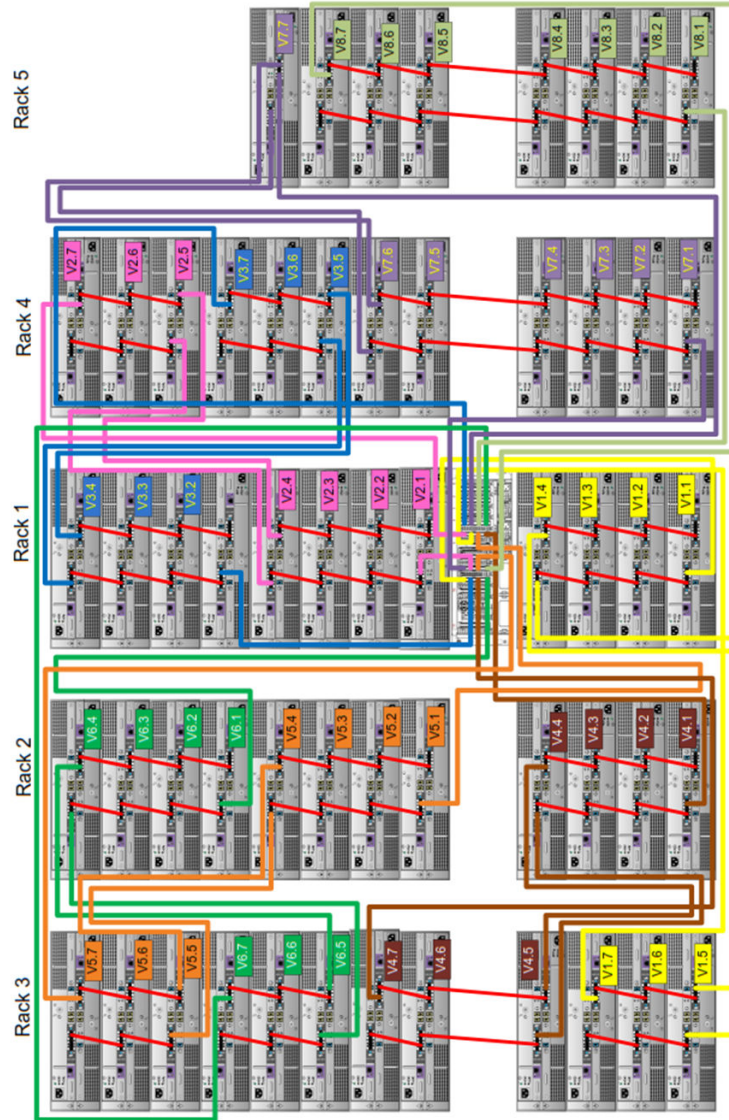
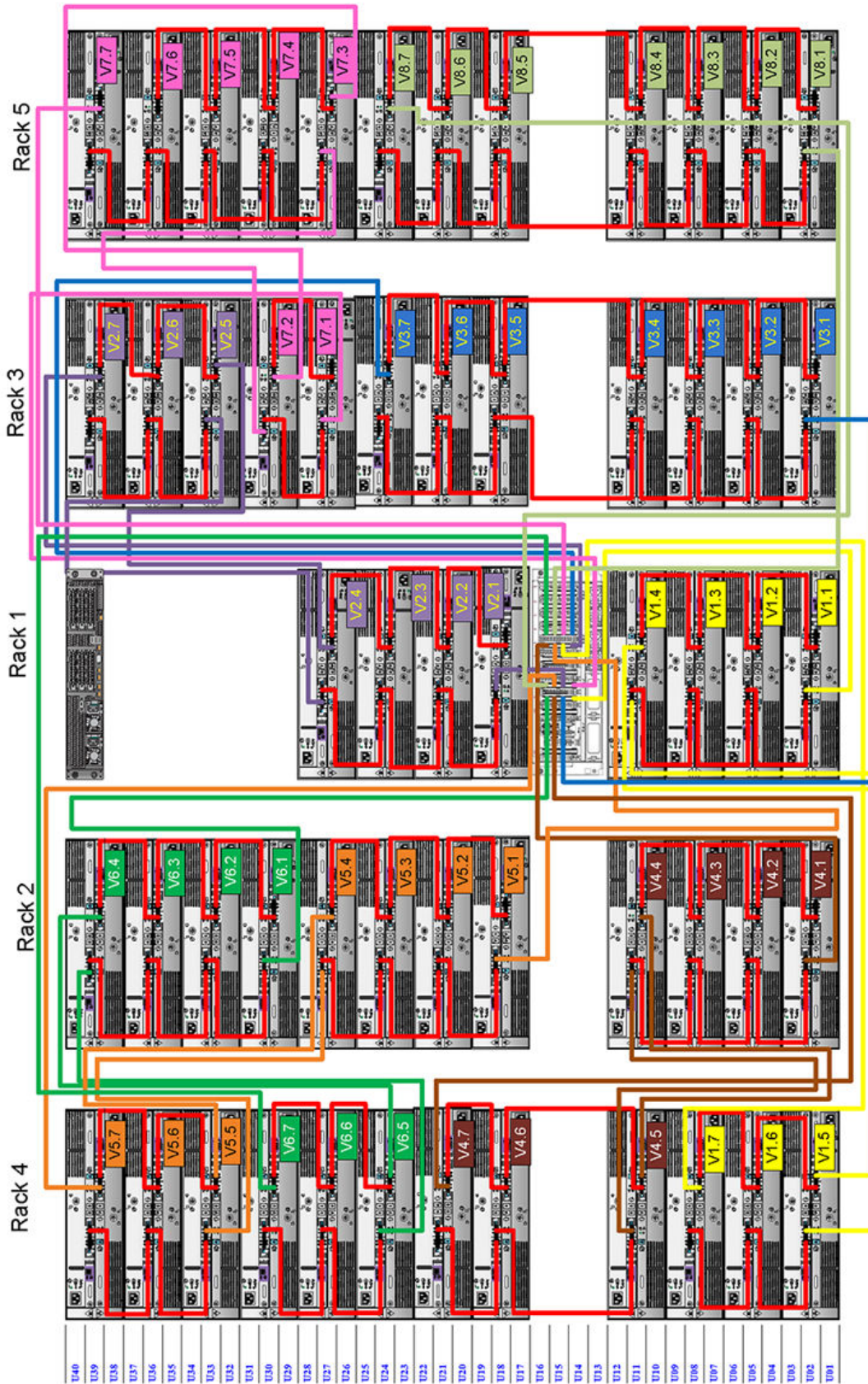


Figure 12 Recommended cabling for DD990 with extended retention and integrated with Avamar



The tables below provide guidelines for configuring DD990 systems using a mixture of ES20 and ES30 shelves.

**Table 16** DD990 cabling (mixed ES20 and ES30): ES20 1-3

Rack 2	Rack 1		Rack 2	Rack 1		Rack 2	Rack 1
ES30 V4.5	ES30 V4.3		ES30 V4.4	ES30 V4.2		ES30 V6.5	ES30 V6.1
ES30 V4.4	ES30 V4.2		ES30 V4.3	ES30 V4.1		ES30 V6.4	ES30 V3.4
ES30 V6.5*	ES30 V4.1		ES30 V6.5*	ES30 V3.4		ES30 V6.3	ES30 V3.3
ES30 V6.4	ES30 V3.4		ES30 V6.4	ES30 V3.3		ES30 V6.2	ES30 V3.2
ES30 V6.3	ES30 V3.3		ES30 V6.3	ES30 V3.2		ES30 V5.4	ES30 V3.1
ES30 V6.2	ES30 V3.2		ES30 V6.2	ES30 V3.1		ES30 V5.3	ES30 V2.4
ES30 V6.1	ES30 V3.1		ES30 V6.1	ES30 V2.4		ES30 V5.2	ES30 V2.3
ES30 V5.5*	ES30 V2.4		ES30 V5.5*	ES30 V2.3		ES30 V5.1	ES30 V2.2
Empty	DD990		Empty	DD990		Empty	DD990
ES30 V5.4	ES30 V2.3		ES30 V5.4	ES30 V2.2		ES30 V4.4	ES30 V2.1
ES30 V5.3	ES30 V2.2		ES30 V5.3	ES30 V2.1		ES30 V4.3	ES20 V1.3
ES30 V5.2	ES30 V2.1		ES30 V5.2	ES20 V1.2		ES30 V4.2	ES20 V1.2
ES30 V5.1	ES20 V1.1		ES30 V5.1	ES20 V1.1		ES30 V4.1	ES20 V1.1
1 ES20			2 ES20			3 ES20	

**Note**

Those entries in the table marked with an asterisk (\*) are to be added last.

**Table 17** DD990 cabling (mixed ES20 and ES30): ES20 4-6

Rack 2	Rack 1		Rack 2	Rack 1		Rack 2	Rack 1
ES30 V4.5	ES30 V4.3		ES30 V4.5	ES30 V4.3		ES30 V4.4	ES30 V4.2
ES30 V4.4	ES30 V4.2		ES30 V4.4	ES30 V4.2		ES30 V4.3	ES30 V4.1
ES30 V6.5*	ES30 V4.1		ES30 V6.5*	ES30 V4.1		ES30 V6.5*	ES30 V3.4
ES30 V6.4	ES30 V3.5		ES30 V6.4	ES30 V3.4		ES30 V6.4	ES30 V3.3
ES30 V6.3	ES30 V3.4		ES30 V6.3	ES30 V3.3		ES30 V6.3	ES30 V3.2
ES30 V6.2	ES30 V3.3		ES30 V6.2	ES30 V3.2		ES30 V6.2	ES30 V3.1
ES30 V6.1	ES30 V3.2		ES30 V6.1	ES30 V3.1		ES30 V6.1	ES20 V2.3
ES30 V5.5*	ES30 V3.1		ES30 V5.5*	ES20 V2.2		ES30 V5.5*	ES20 V2.2
Empty	DD990		Empty	DD990		Empty	DD990
ES30 V5.4	ES20 V2.2		ES30 V5.4	ES20 V2.1		ES30 V5.4	ES20 V2.1
ES30 V5.3	ES20 V2.1		ES30 V5.3	ES20 V1.3		ES30 V5.3	ES20 V1.3
ES30 V5.2	ES20 V1.2		ES30 V5.2	ES20 V1.2		ES30 V5.2	ES20 V1.2



**Table 17** DD990 cabling (mixed ES20 and ES30): ES20 4-6 (continued)

Rack 2	Rack 1		Rack 2	Rack 1		Rack 2	Rack 1
ES30 V5.1	ES20 V1.1		ES30 V5.1	ES20 V1.1		ES30 V5.1	ES20 V1.1
4 ES20			5 ES20			6 ES20	

**Note**

Those entries in the table marked with an asterisk (\*) are to be added last.

**Table 18** DD990 cabling (mixed ES20 and ES30): ES20 7-9

Rack 2	Rack 1		Rack 2	Rack 1		Rack 2	Rack 1
ES30 V6.4	ES30 V3.5		ES30 V6.4	ES30 V3.4		ES30 V4.5	ES30 V4.3
ES30 V6.3	ES30 V3.4		ES30 V6.3	ES30 V3.3		ES30 V4.4	ES30 V4.2
ES30 V6.2	ES30 V3.3		ES30 V6.2	ES30 V3.2		ES30 V6.5*	ES30 V4.1
ES30 V6.1	ES30 V3.2		ES30 V6.1	ES30 V3.1		ES30 V6.4	ES20 V3.3
ES30 V5.4	ES30 V3.1		ES30 V5.4	ES20 V2.4		ES30 V6.3	ES20 V3.2
ES30 V5.3	ES20 V2.4		ES30 V5.3	ES20 V2.3		ES30 V6.2	ES20 V3.1
ES30 V5.2	ES20 V2.3		ES30 V5.2	ES20 V2.2		ES30 V6.1	ES20 V2.3
ES30 V5.1	ES20 V2.2		ES30 V5.1	ES20 V2.1		ES30 V5.5*	ES20 V2.2
Empty	DD990		Empty	DD990		Empty	DD990
ES30 V4.4	ES20 V2.1		ES30 V4.4	ES20 V1.4		ES30 V5.4	ES20 V2.1
ES30 V4.3	ES20 V1.3		ES30 V4.3	ES20 V1.3		ES30 V5.3	ES20 V1.3
ES30 V4.2	ES20 V1.2		ES30 V4.2	ES20 V1.2		ES30 V5.2	ES20 V1.2
ES30 V4.1	ES20 V1.1		ES30 V4.1	ES20 V1.1		ES30 V5.1	ES20 V1.1
7 ES20			8 ES20			9 ES20	

**Note**

Those entries in the table marked with an asterisk (\*) are to be added last.

**Table 19** DD990 cabling (mixed ES20 and ES30): ES20 10-12

Rack 2	Rack 1		Rack 2	Rack 1		Rack 2	Rack 1
ES30 V4.4	ES30 V4.2		ES30 V6.4	ES30 V6.5		ES30 V6.4	ES20 V3.4
ES30 V4.3	ES30 V4.1		ES30 V6.3	ES20 V3.3		ES30 V6.3	ES20 V3.3
ES30 V6.5*	ES20 V3.3		ES30 V6.2	ES20 V3.2		ES30 V6.2	ES20 V3.2
ES30 V6.4	ES20 V3.2		ES30 V6.1	ES20 V3.1		ES30 V6.1	ES20 V3.1
ES30 V6.3	ES20 V3.1		ES30 V5.4	ES20 V2.4		ES30 V5.4	ES20 V2.4
ES30 V6.2	ES20 V2.3		ES30 V5.3	ES20 V2.3		ES30 V5.3	ES20 V2.3

**Table 19** DD990 cabling (mixed ES20 and ES30): ES20 10-12 (continued)

Rack 2	Rack 1		Rack 2	Rack 1		Rack 2	Rack 1
ES30 V6.1	ES20 V2.2		ES30 V5.2	ES20 V2.2		ES30 V5.2	ES20 V2.2
ES30 V5.5*	ES20 V2.1		ES30 V5.1	ES20 V2.1		ES30 V5.1	ES20 V2.1
Empty	DD990		Empty	DD990		Empty	DD990
ES30 V5.4	ES20 V1.4		ES30 V4.4	ES20 V1.4		ES30 V4.4	ES20 V1.4
ES30 V5.3	ES20 V1.3		ES30 V4.3	ES20 V1.3		ES30 V4.3	ES20 V1.3
ES30 V5.2	ES20 V1.2		ES30 V4.2	ES20 V1.2		ES30 V4.2	ES20 V1.2
ES30 V5.1	ES20 V1.1		ES30 V4.1	ES20 V1.1		ES30 V4.1	ES20 V1.1
10 ES20			11 ES20			12 ES20	

**Note**

Those entries in the table marked with an asterisk (\*) are to be added last.

**Data Domain Extended Retention for DD990 systems**

The rules for this system are the same as the DD990 except the maximum number of ES30s for the Extended Retention system in a set is increased to 7. There is no change to the ES20 maximums. The maximum number of shelves will be less than 56 because of the rules regarding the maximum number of ES20s in a set. It is recommended that Professional Services be contacted for these large, mixed shelf systems.

Data Domain Extended Retention systems for DD990 have four quad-port SAS cards and support eight sets with a maximum of seven shelves per set.

**Note**

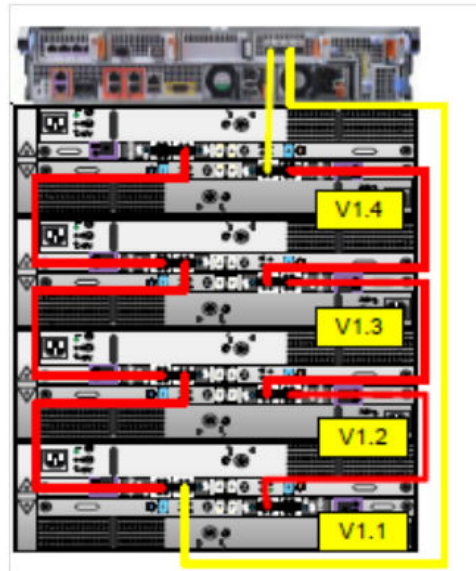
As mentioned, you cannot combine ES20 and ES30 shelves in the same set.

**DD2500 cabling**

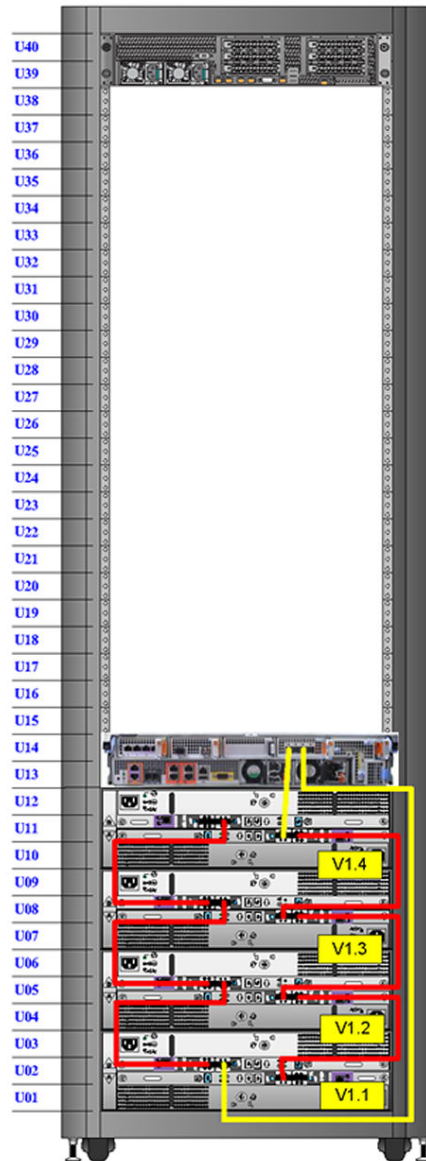
DD2500 systems ONLY support SAS based shelves. The figures show cabling for a DD2500 and a system integrated with Avamar.

Cables connect to ports P0 and P2.

Figure 13 Recommended DD2500 cabling



**Figure 14** Recommended cabling for DD2500 integrated with Avamar



## DD4200, DD4500, and DD7200 cabling

There are a few rules that must be followed when adding a mixture of ES20, ES30 SATA, and ES30 SAS shelves to your system. If a system does not follow ALL of these rules it is not a legitimate configuration.

Prerequisites:

- Follow the minimum and maximum shelf capacity configuration provided in the table.
- You cannot have ES20 and ES30 shelves in the same set.
- You cannot have ES30 SATA and ES30 SAS shelves in the same set.
- You cannot exceed the maximum amount of raw capacity displayed in the product's cabling table.

- The maximum number of shelves displayed in the product's cabling table cannot be exceeded.
- You cannot have more than four ES20s in a single set (maximum preference is three).
- You cannot have more than five ES30s in a single set (maximum preference is four).
- You can have a maximum of seven ES30s for systems with Extended Retention software.
- There are no specific placement or cabling requirements for the metadata shelves for DD Cloud Tier configurations. These shelves can be installed and cabled the same way as standard ES30 shelves.

---

#### Note

An ES20 requires more power than an ES30. Ensure that your rack is configured to handle the power needs.

---

The tables below show how to configure a mixed system. To use the tables, go to the appropriate system. Then find the number of ES20s that are to be configured in the first column. The next column defines the number of ES20 sets. If there are multiple rows with the same number of ES20s then pick the row with the appropriate number of ES20 SATA shelves. The next column in that row defines the number of sets of ES30 SATA shelves. Finally, there may be entries for the number of desired ES30 SAS shelves and the number of sets to be used.

If the combinations of shelves exceed the supported usable storage, there may not be an entry. The entries are based on the smallest usable storage per shelf type (12TB for ES20, 12 TB for ES30 SATA, and 24TB for ES30 SAS). Always check that the sum of the usable storage of all of the shelves does not exceed the supported usable storage of the configuration.

**Table 20** Minimum and maximum configurations

System	Minimum appliance shelf count	Maximum appliance shelf count	DD Cloud Tier systems in TB	Extended Retention systems (ER) in TB	Max shelves for ER
4200 (192)	1	16	<ul style="list-style-type: none"> <li>• 189</li> <li>• 90 for metadata</li> </ul>	<ul style="list-style-type: none"> <li>• DD OS 5.4 and earlier: 576</li> <li>• DD OS 5.5 and later: 385</li> </ul>	32
4500 (288)	2	20	<ul style="list-style-type: none"> <li>• 285</li> <li>• 120 for metadata</li> </ul>	<ul style="list-style-type: none"> <li>• DD OS 5.4 and earlier: 1152</li> <li>• DD OS 5.5 and later: 576</li> </ul>	40
7200 (384)	3	20	<ul style="list-style-type: none"> <li>• 428</li> <li>• 240 for metadata</li> </ul>	<ul style="list-style-type: none"> <li>• DD OS 5.4 and earlier: 1728</li> <li>• DD OS 5.5 and later: 768</li> </ul>	56

Systems without Extended Retention or DD Cloud Tier all support four chains. The following tables show combinations of ES20 and ES30 shelves. For combinations of any two types of shelves, these tables can be used as a guide.

**Table 21** DD4200 cabling information

DD4200					
ES20	ES20 chains	ES30 SATA	ES30 SATA chains	ES30 SAS	ES30 SAS chains
13-16	4	0	0	0	0
9-12	3	1-5	1	0	0
9-12	3	0	0	1-3	1
5-8	2	6-10	2	0	0
5-8	2	1-5	1	1-5	1
5-8	2	0	0	5	2
5-8	2	0	0	1-4	1
1-4	1	8-12	3	0	0
1-4	1	6-10	2	1-5	1
1-4	1	1-5	1	1-4	1
1-4	1	1-5	1	5-7	2
1-4	1	0	0	1-4	1
1-4	1	0	0	5-7	2
0	0	13-16	4	0	0
0	0	9-12	3	1-3	1
0	0	5-8	2	1-4	1
0	0	5-8	2	5	2
0	0	1-4	1	1-4	1
0	0	1-4	1	5-7	2
0	0	0	0	1-4	1
0	0	0	0	5-8	2

**Table 22** DD4500 cabling information

DD4500					
ES20	ES20 chains	ES30 SATA	ES30 SATA chains	ES30 SAS	ES30 SAS chains
13-16	4	0	0	0	0
9-12	3	1-5	1	0	0
9-12	3	0	0	1-5	1
5-8	2	1-5	1	1-5	1
5-8	2	6-8	2	0	0
5-8	2	0	0	1-5	1

**Table 22** DD4500 cabling information (continued)

<b>DD4500</b>					
5-8	2	0	0	6-10	2
1-4	1	9-12	3	0	0
1-4	1	5-8	2	1-5	1
1-4	1	1-4	1	1-5	1
1-4	1	1-4	1	6-10	2
1-4	1	0	0	1-4	1
1-4	1	0	0	5-8	2
1-4	1	0	0	9-11	3
0	0	16-21	4	0	0
0	0	11-15	3	1-5	1
0	0	6-10	2	1-4	1
0	0	6-10	2	5-9	2
0	0	1-5	1	1-4	1
0	0	1-5	1	5-8	2
0	0	1-5	1	9-11	3
0	0	0	0	1-4	1
0	0	0	0	5-8	2
0	0	0	0	9-12	3

**Table 23** DD7200 cabling information

<b>DD7200</b>					
ES20	ES20 chains	ES30 SATA	ES30 SATA chains	ES30 SAS	ES30 SAS chains
13-16	4	0	0	0	0
9-12	3	1-5	1	0	0
9-12	3	0	0	1-5	1
5-8	2	1-5	1	1-5	1
5-8	2	6-8	2	0	0
5-8	2	0	0	1-5	1
5-8	2	0	0	6-10	2
1-4	1	11-15	3	0	0
1-4	1	6-10	2	1-5	1
1-4	1	1-5	1	1-5	1
1-4	1	1-5	1	6-10	2

**Table 23** DD7200 cabling information (continued)

DD7200					
1-4	1	0	0	1-5	1
1-4	1	0	0	6-10	2
1-4	1	0	0	11-15	3
0	0	16-20	4	0	0
0	0	11-15	3	1-5	1
0	0	6-10	2	1-5	1
0	0	6-10	2	6-10	2
0	0	1-5	1	1-5	1
0	0	1-5	1	6-10	2
0	0	1-5	1	11-15	3
0	0	0	0	1-4	1
0	0	0	0	5-8	2
0	0	0	0	9-12	3
0	0	0	0	13-16/18	4

The following figures show cabling for base systems, systems with the Extended Retention software option, and systems integrated with an Avamar system.



Figure 15 Recommended DD4200 cabling

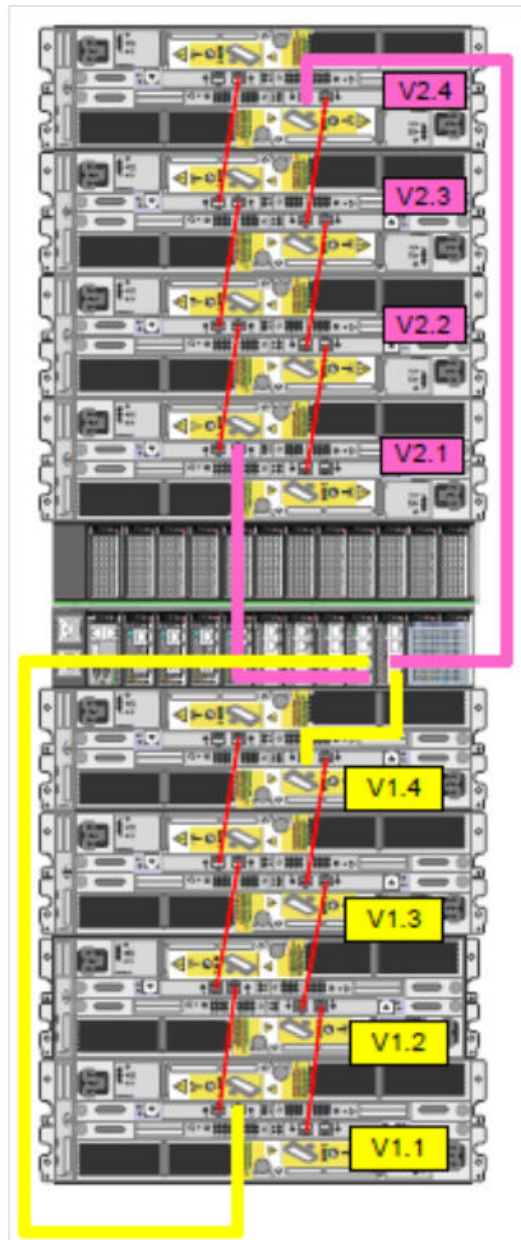
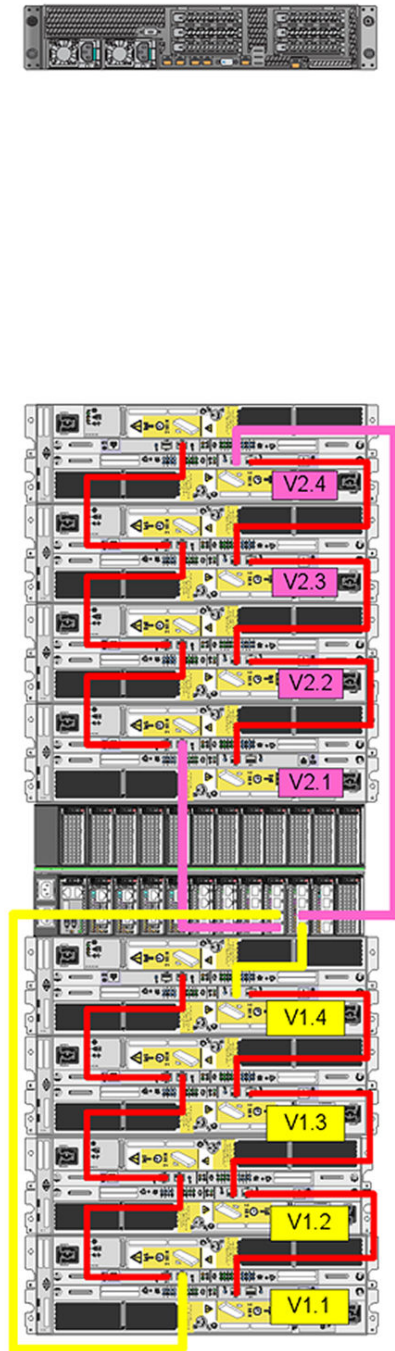
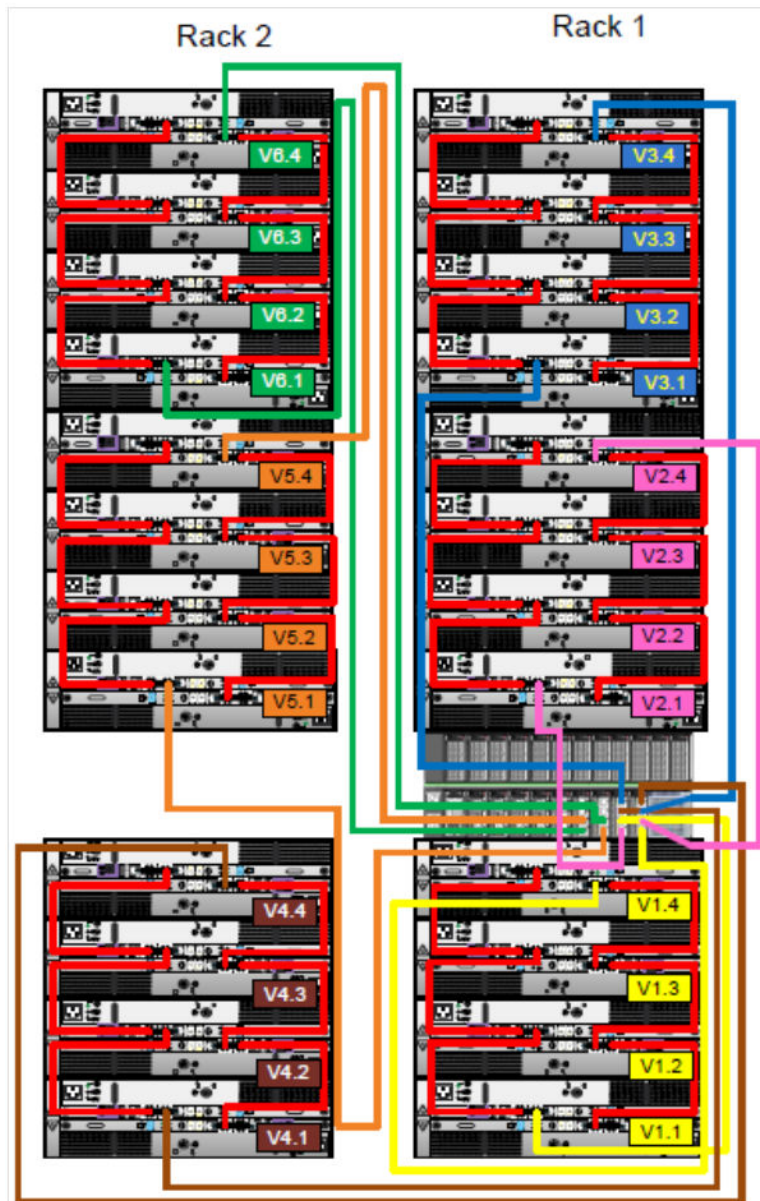


Figure 16 Recommended cabling for DD4200 integrated with Avamar



**Figure 17** Recommended cabling for DD4200 system with extended retention software or DD Cloud Tier



**Figure 18** Recommended cabling for DD4200 with extended retention and integrated with Avamar

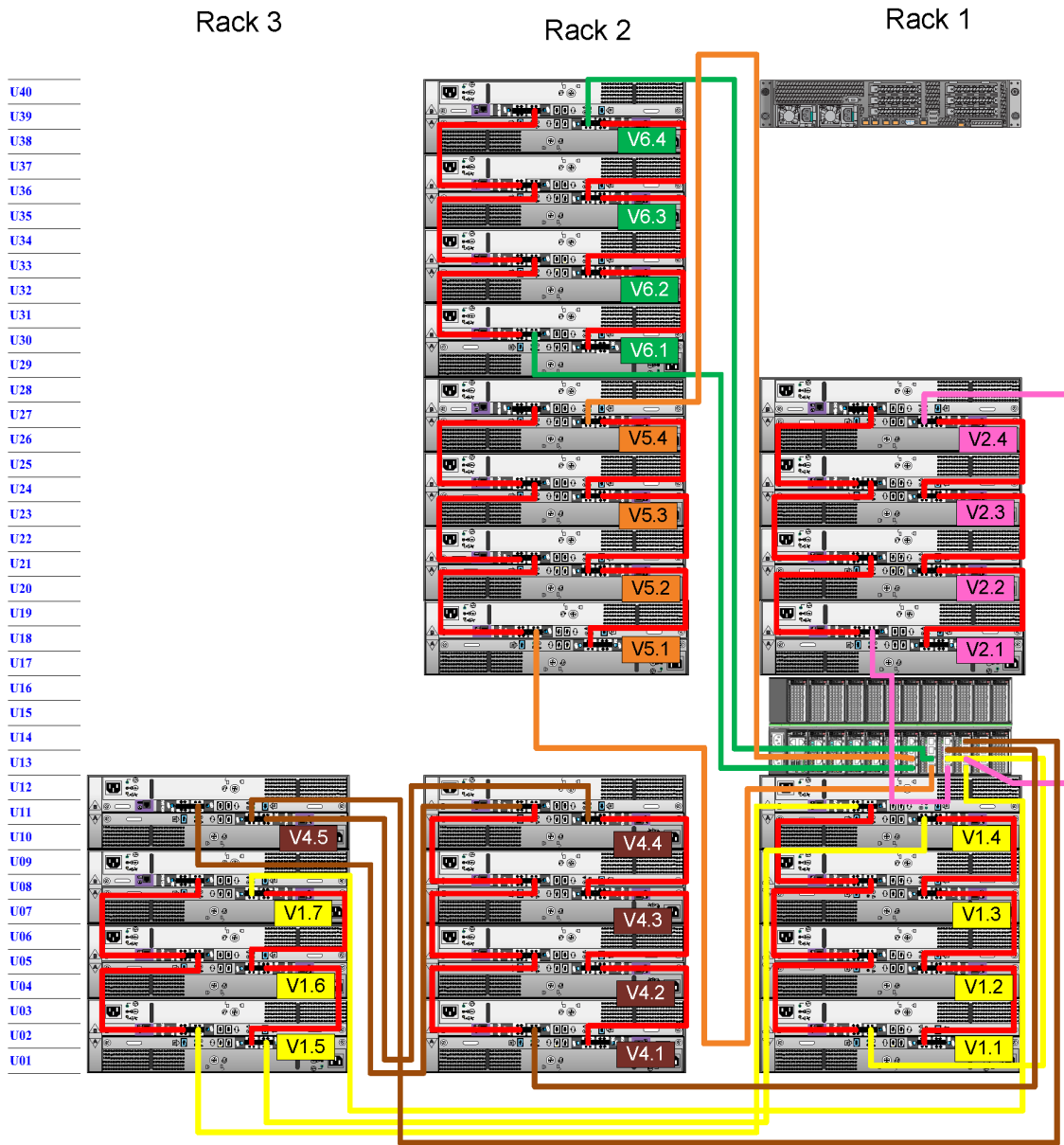


Figure 19 Recommended DD4500 cabling

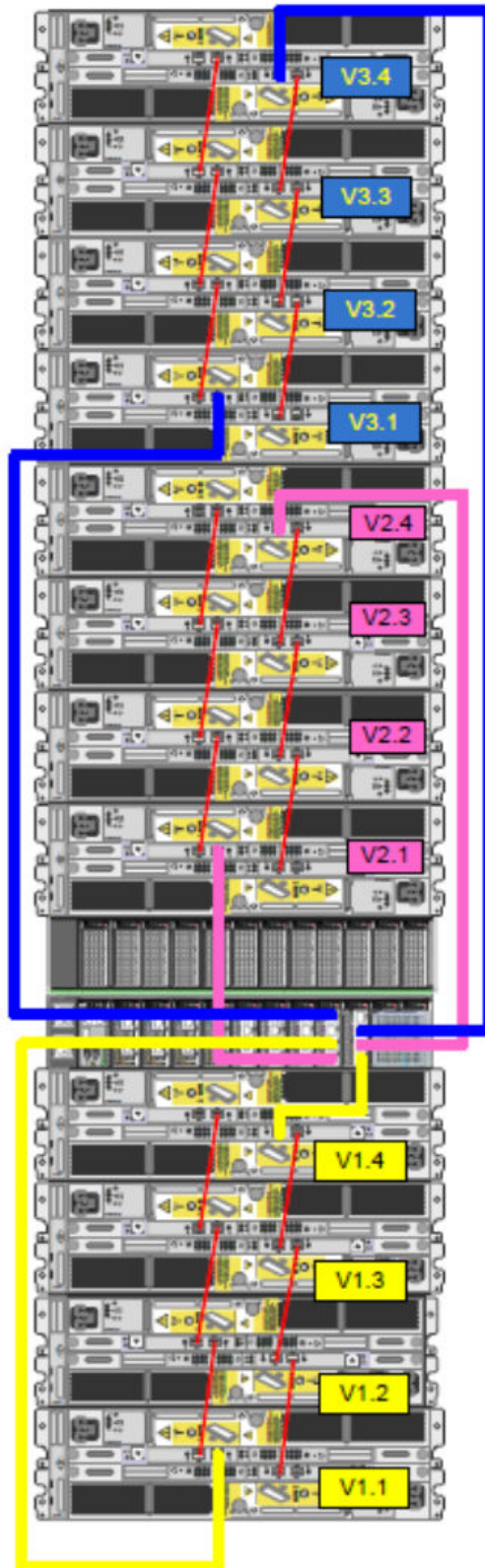
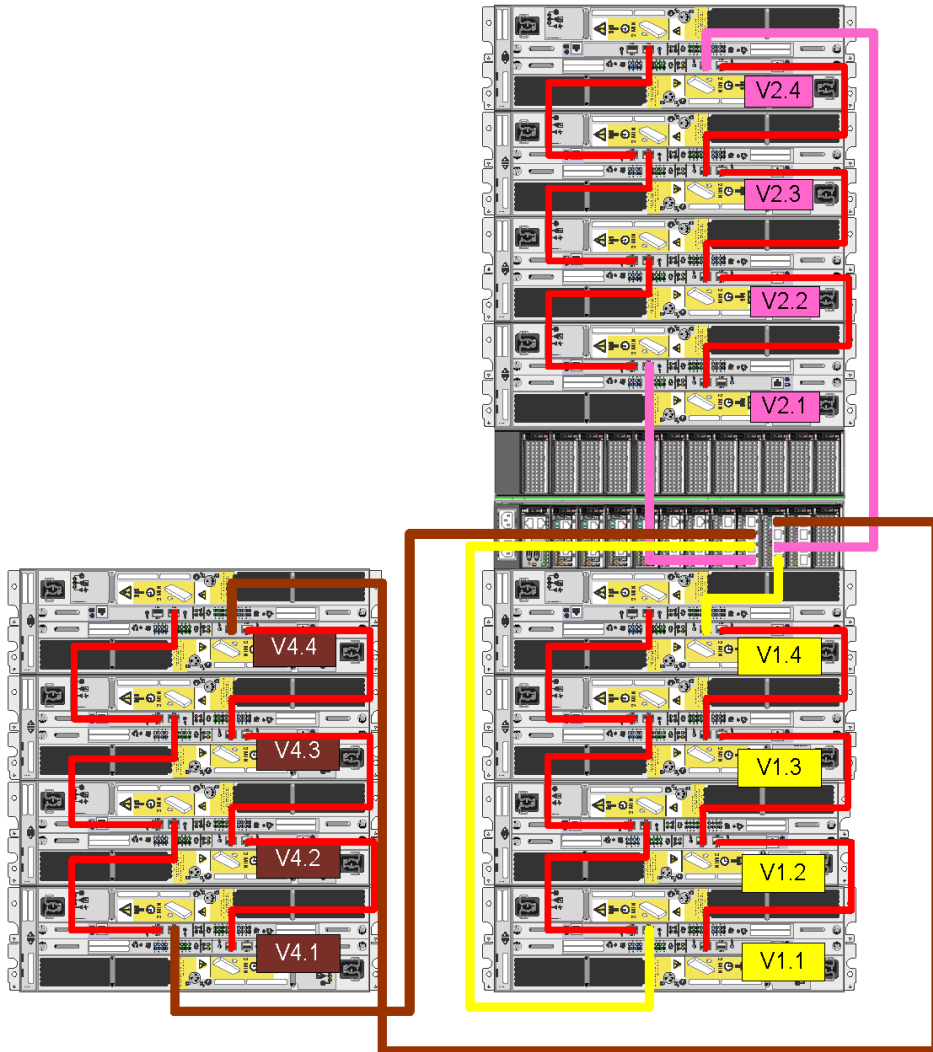


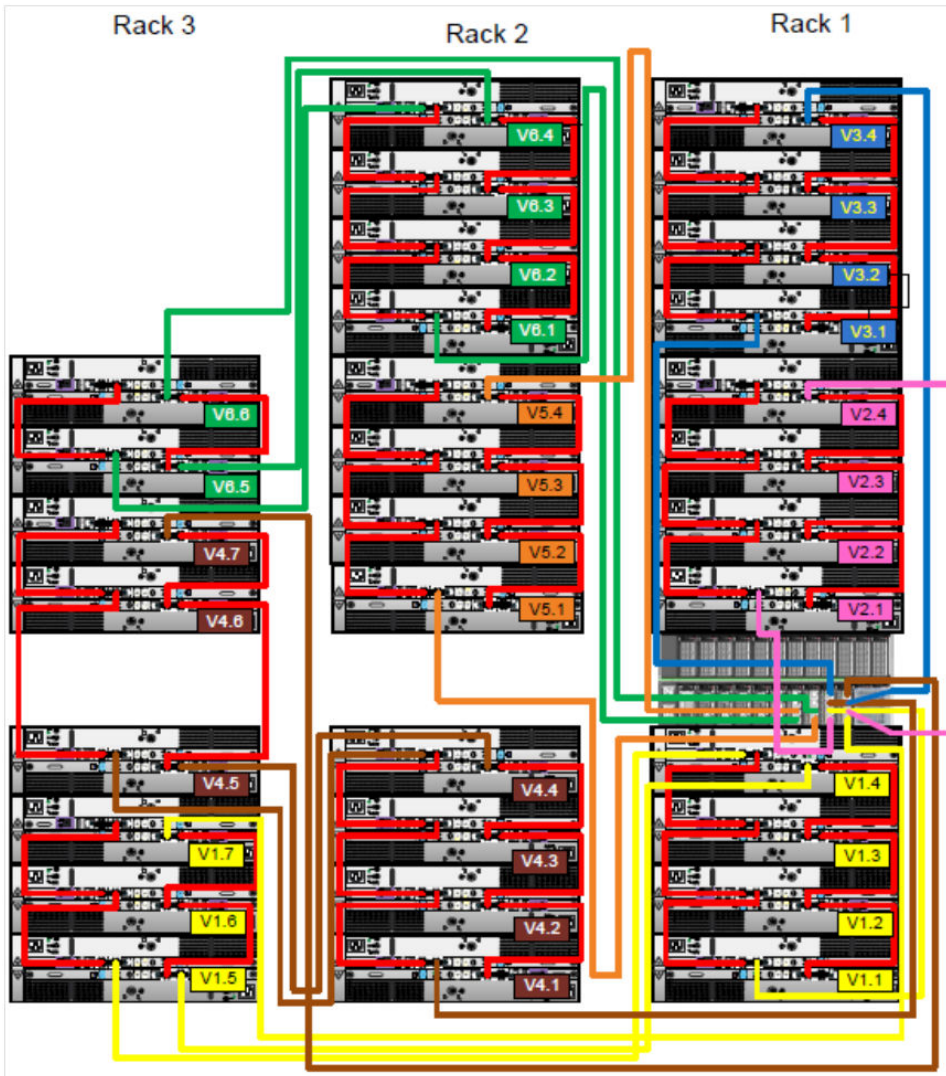
Figure 20 Recommended cabling for DD4500 integrated with Avamar

Rack 2

Rack 1



**Figure 21** Recommended cabling for DD4500 with extended retention software or DD Cloud Tier



**Figure 22** Recommended cabling for DD4500 with extended retention and integrated with Avamar

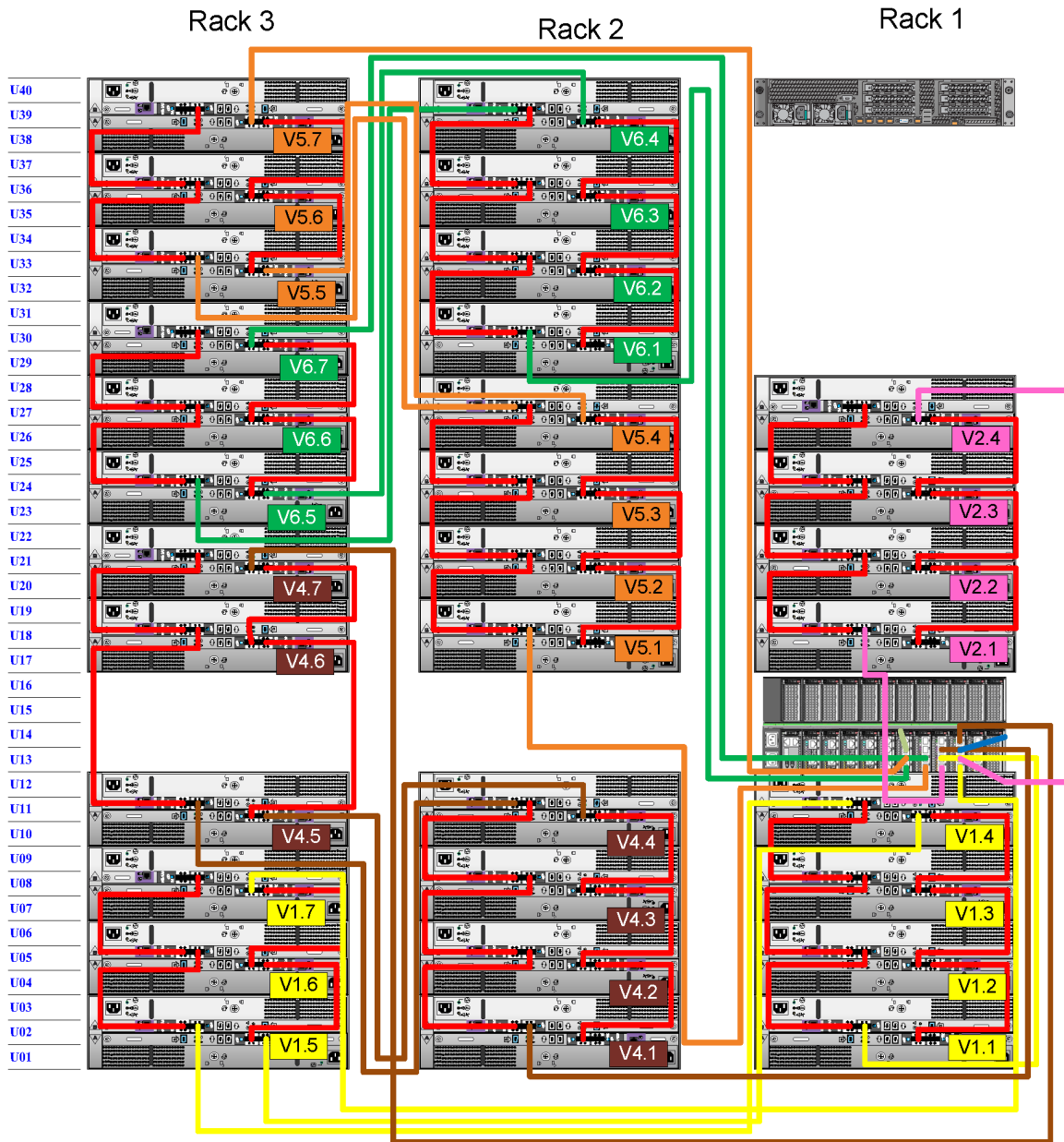




Figure 23 Recommended DD7200 cabling

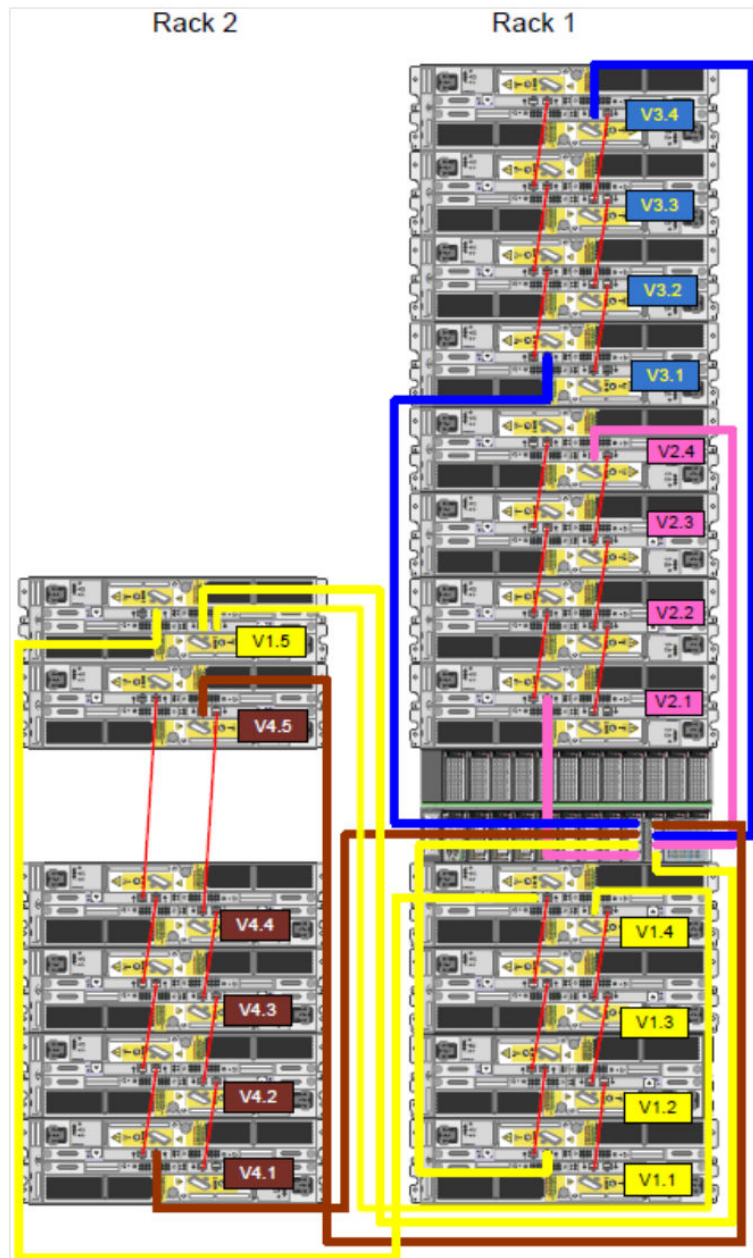


Figure 24 Recommended cabling for DD7200 integrated with Avamar

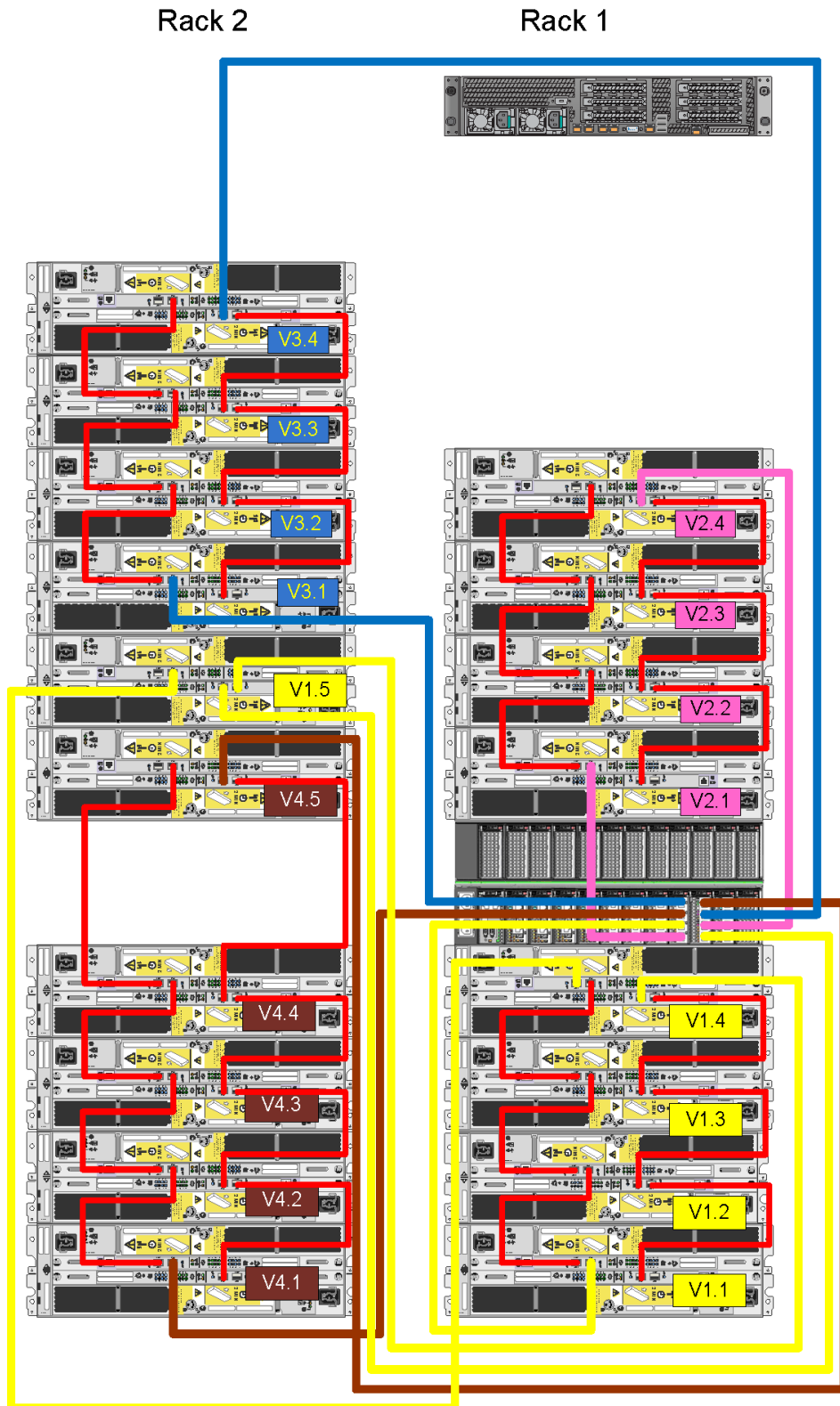
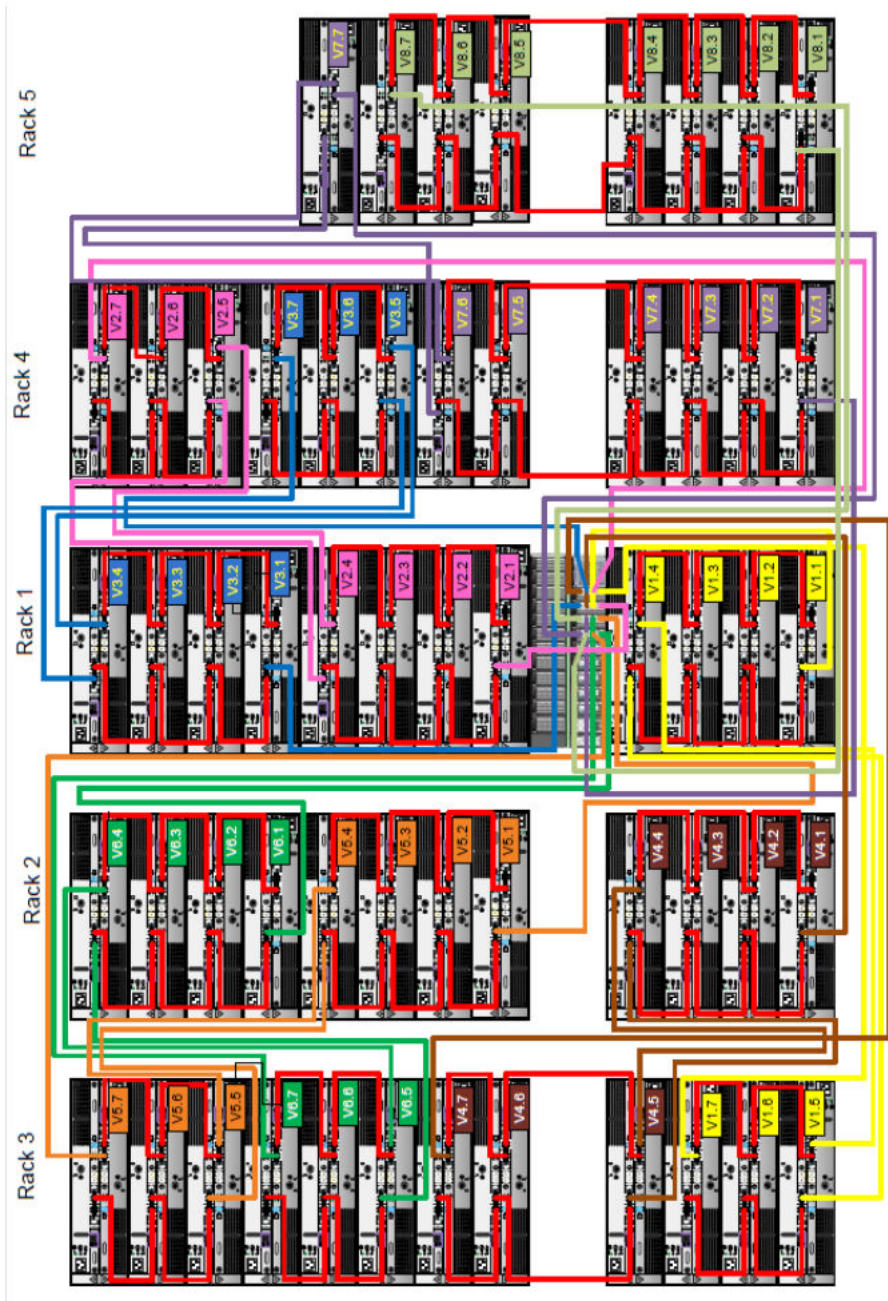
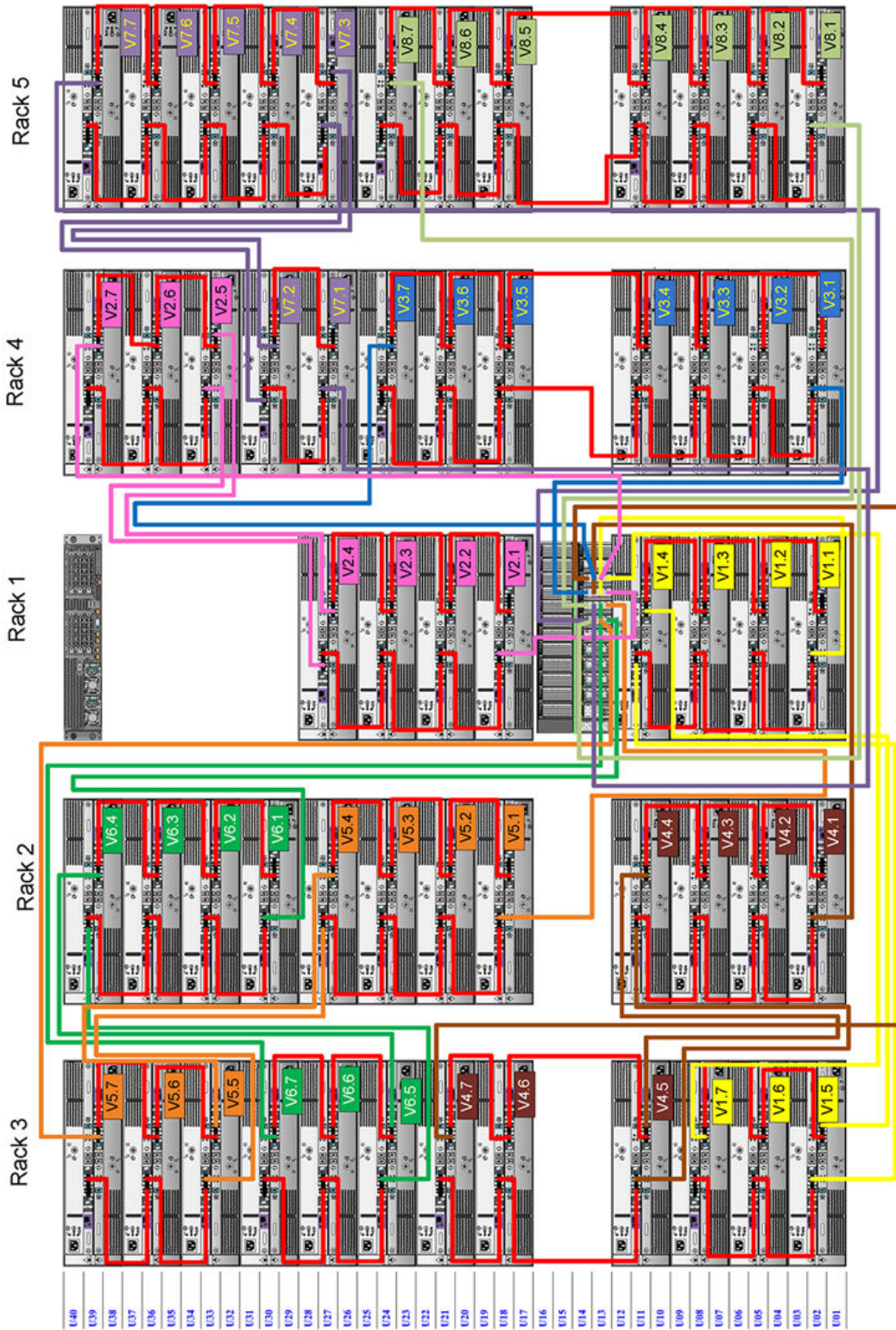


Figure 25 Recommended cabling for DD7200 with extended retention software or DD Cloud Tier



**Figure 26** Recommended cabling for DD7200 with extended retention and integrated with Avamar



## DD6300, DD6800, and DD9300 cabling

There are a few rules that must be followed when adding a mixture of and other shelf types to your system.

**⚠ CAUTION**

**If a system does not follow ALL of these rules it is not a legitimate configuration.**

Prerequisites:

- You cannot exceed the maximum amount of raw capacity displayed in the cabling table for each system.
- You cannot exceed the maximum number of shelves displayed in the cabling table for each system.
- There are no specific placement or cabling requirements for SSD shelves, or the metadata shelves for DD Cloud Tier configurations. These shelves can be installed and cabled the same way as standard ES30 shelves.

**Table 24** Minimum and maximum configurations

System	Appliance	Minimum appliance shelf count*	Max appliance shelf count
DD6300	48 TB usable	0	1
DD6300 w/ Expansion	144 TB usable	1	5
DD6800	144 TB usable	2	28
DD6800 w/ Expansion	288 TB usable	2	28
DD6800 w/ High Availability (HA)	288 TB usable	2	28
DD6800 w/ Extended Retention (ER)	576 TB usable	2	28
DD6800 w/ DD Cloud Tier	288 TB usable (96 TB for DD Cloud Tier)	2	28
DD6800 w/ HA and DD Cloud Tier	288 TB usable (96 TB for DD Cloud Tier)	2	28
DD9300	384 TB usable	3	28
DD9300 w/ Expansion	720 TB usable	3	28
DD9300 w/ HA	720 TB usable	3	28
DD9300 w/ ER	1440 TB usable	7	28
DD9300 w/ DD Cloud Tier	720 TB usable (192 TB for DD Cloud Tier)	7	28

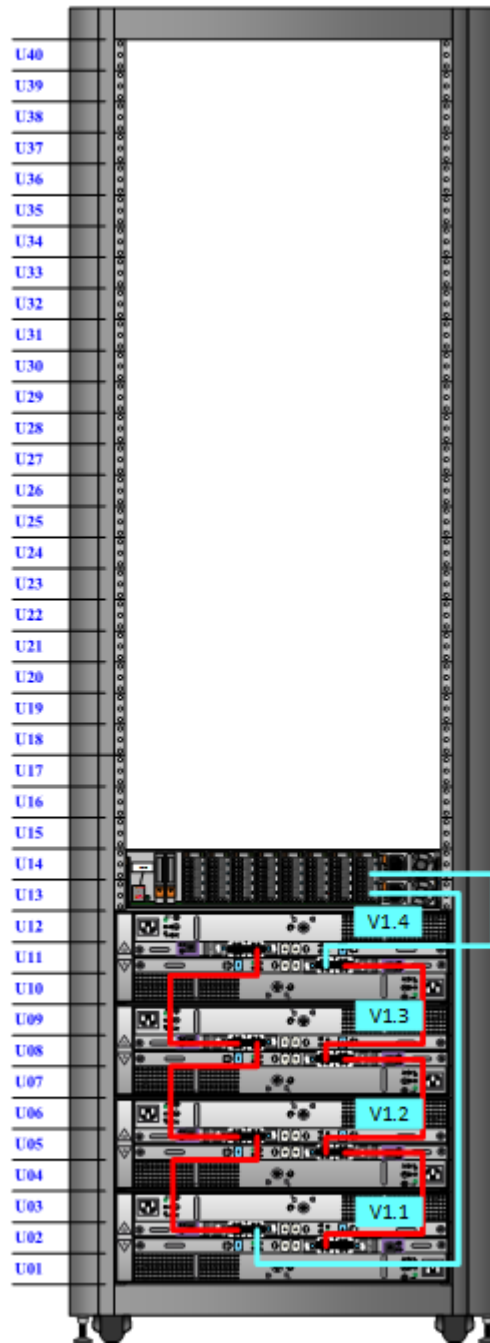
**Table 24** Minimum and maximum configurations (continued)

<b>System</b>	<b>Appliance</b>	<b>Minimum appliance shelf count*</b>	<b>Max appliance shelf count</b>
DD9300 w/ HA and DD Cloud Tier	720 TB usable (192 TB for DD Cloud Tier)	7	28

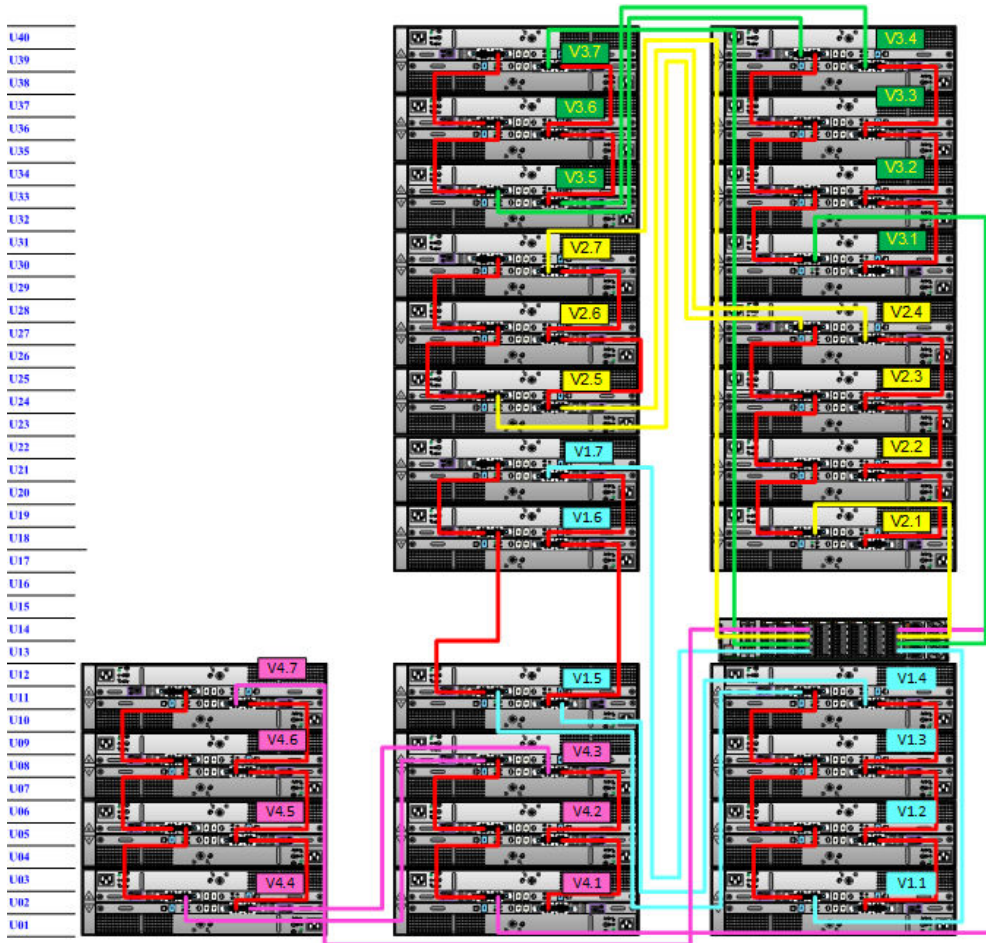
\* The minimum appliance shelf count does not include shelves for DD Cloud Tier.

The cabling diagrams in this section show the maximum configurations for DD6300, DD6800 and DD9300 systems. Not all systems will have all the disk shelves shown in the diagrams.

**Figure 27** Recommended cabling for DD6300 with maximum configuration

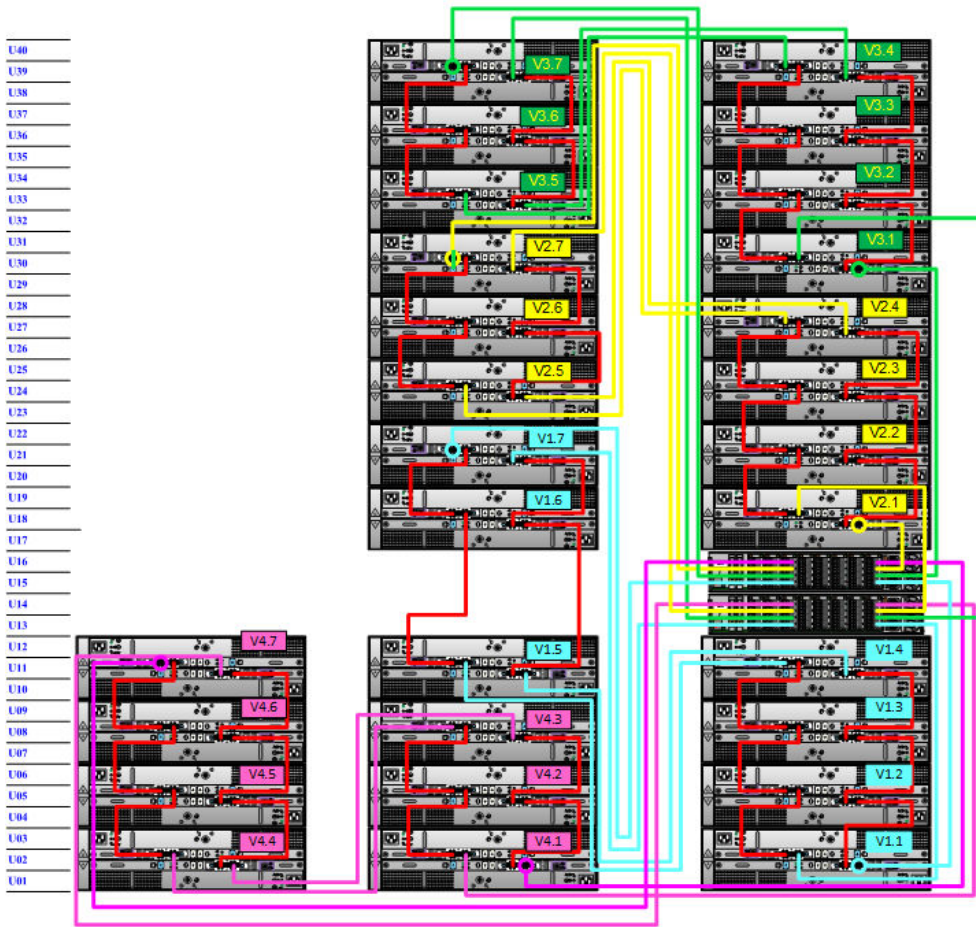


**Figure 28** Recommended cabling for DD6800 and DD9300 single node, DD Cloud Tier, or ER systems with maximum configuration





**Figure 29** Recommended cabling for DD9300 with HA and HA with DD Cloud Tier



## DD9500 and DD9800 cabling

### Note

If a system installation does not follow ALL of these rules, it is not a legitimate configuration.

### Prerequisites:

- Follow the minimum and maximum shelf capacity configuration provided in the table.
- You cannot have ES30 SATA and ES30 SAS shelves in the same set.
- You cannot exceed the maximum amount of raw capacity displayed in the product's cabling table.
- You cannot exceed the maximum number of shelves displayed in the product's cabling table.
- You cannot have more than five ES30s in a single set (maximum of four is preferred).
- You can have seven ES30s for systems with Extended Retention software.
- There are no specific placement or cabling requirements for SSD shelves, or the metadata shelves for DD Cloud Tier configurations. These shelves can be installed and cabled the same way as standard ES30 shelves.

**Table 25** Minimum and maximum configurations

System	DD9500	DD9500 w/ FS15	DD9800
Appliance	864 TB usable	864 TB usable	1008 TB usable
Minimum appliance shelf count	4	4	4
Maximum appliance shelf count	30	30	30
Extended Retention systems (ER)	1728 TB usable	2016 TB usable	2016 TB usable
Maximum shelves for ER	56	56	56
High Availability systems (HA)	864 TB usable	1008 TB usable	1008 TB usable
Maximum shelves for HA	42	42	47
DD Cloud Tier systems	1104 TB usable	1248 TB usable	1248 TB usable
Maximum shelves for DD Cloud Tier	42	42	47

The DD9500 base (non-Extended Retention) and HA systems supports six chains.

The following figures show cabling for base systems, HA systems, and systems with the Extended Retention software option.

---

**Note**

The DD9500 system running DD OS 5.6 does not support any ES20 shelves.

---

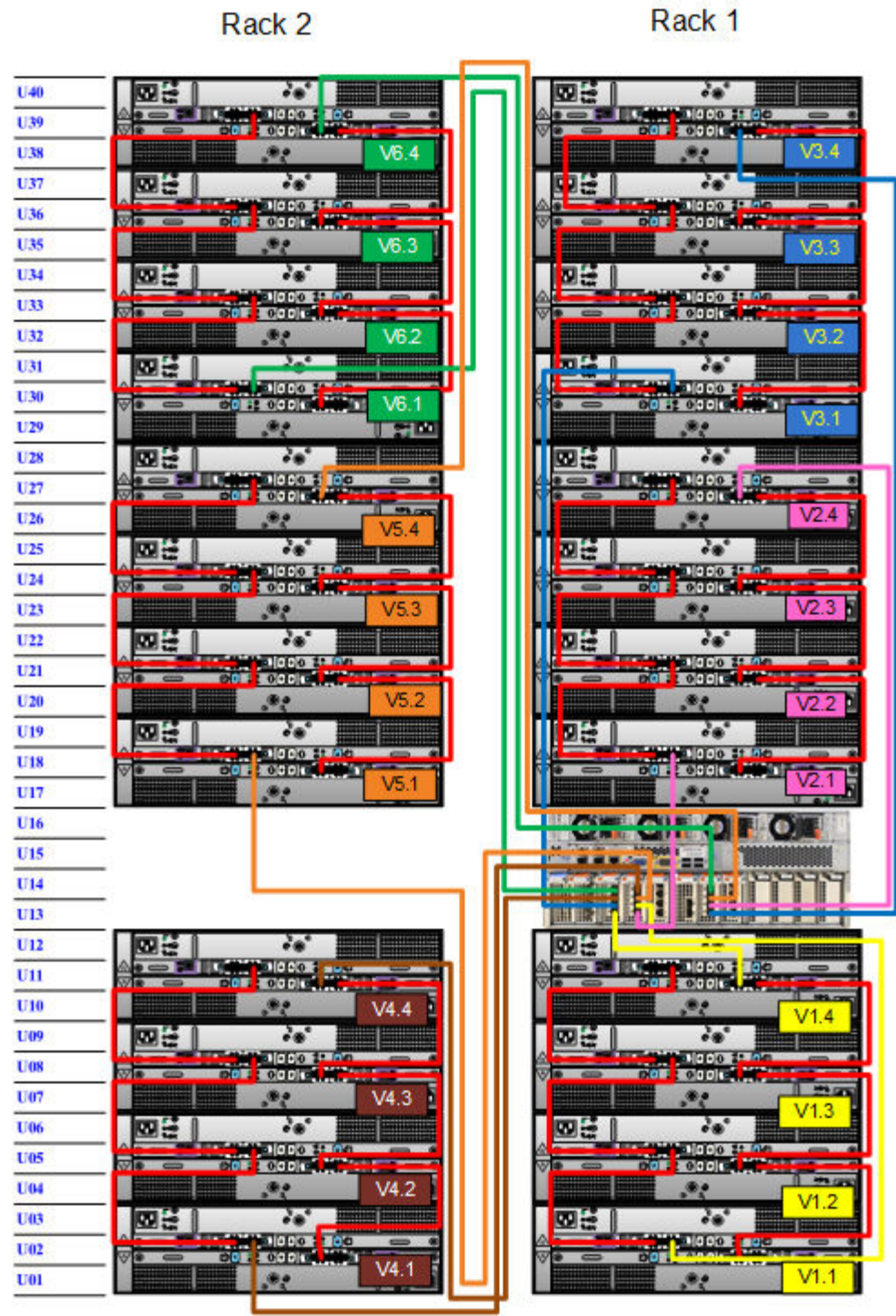
**Note**

The racks are filled from bottom up.

---

The cabling diagrams in this section show the maximum configurations for the DD9500 and DD9800 systems. Not all systems will have all the disk shelves shown in the diagrams.

Figure 30 Cabling for base DD9500 /DD9800 systems



**Figure 31** Cabling for HA DD9500 /DD9800 systems in one rack

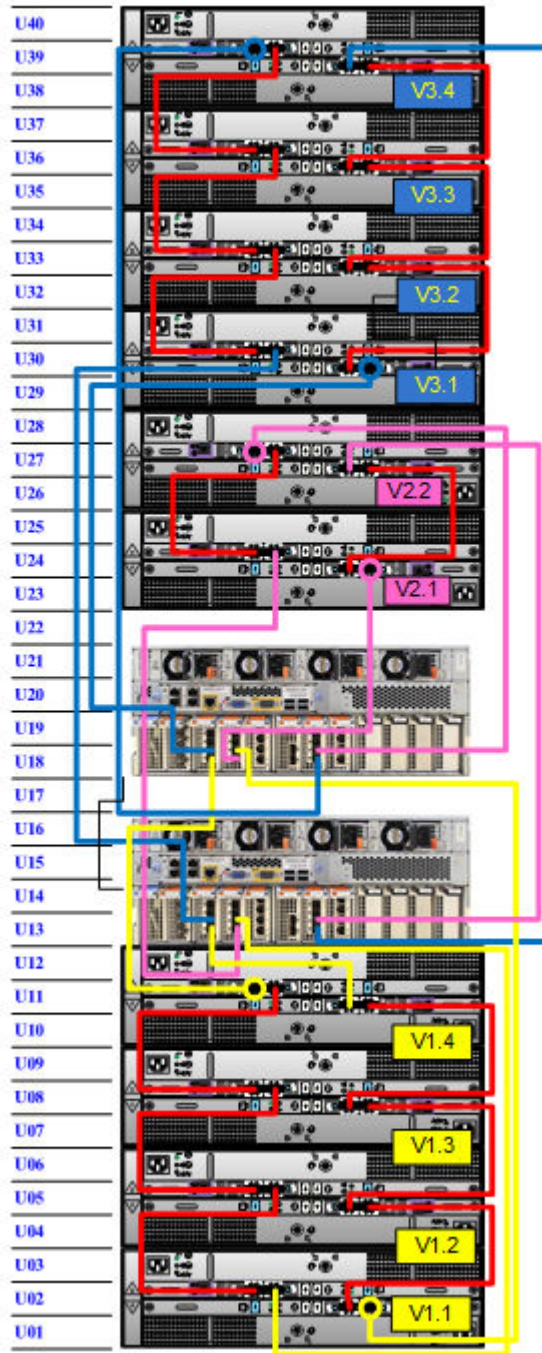
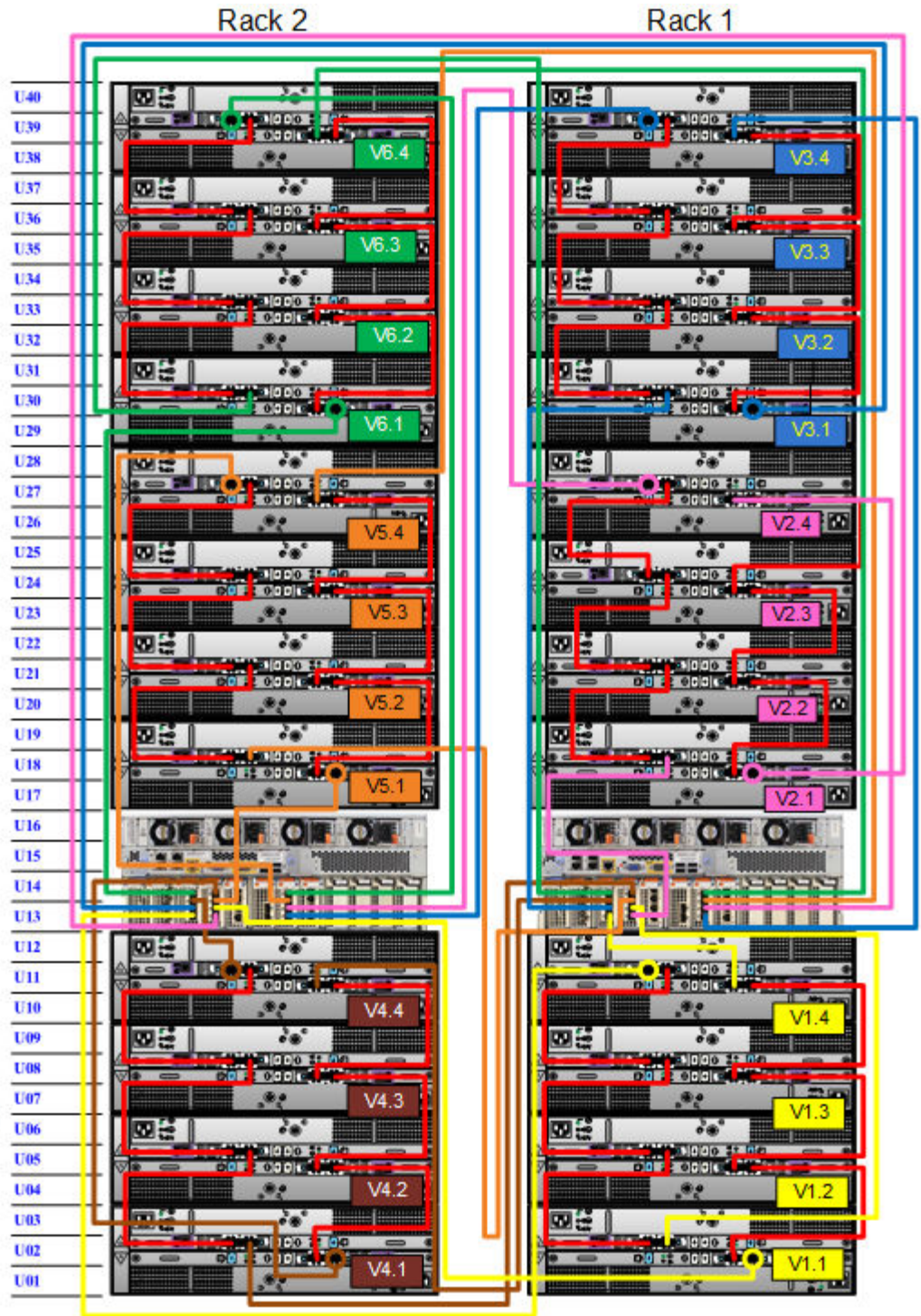
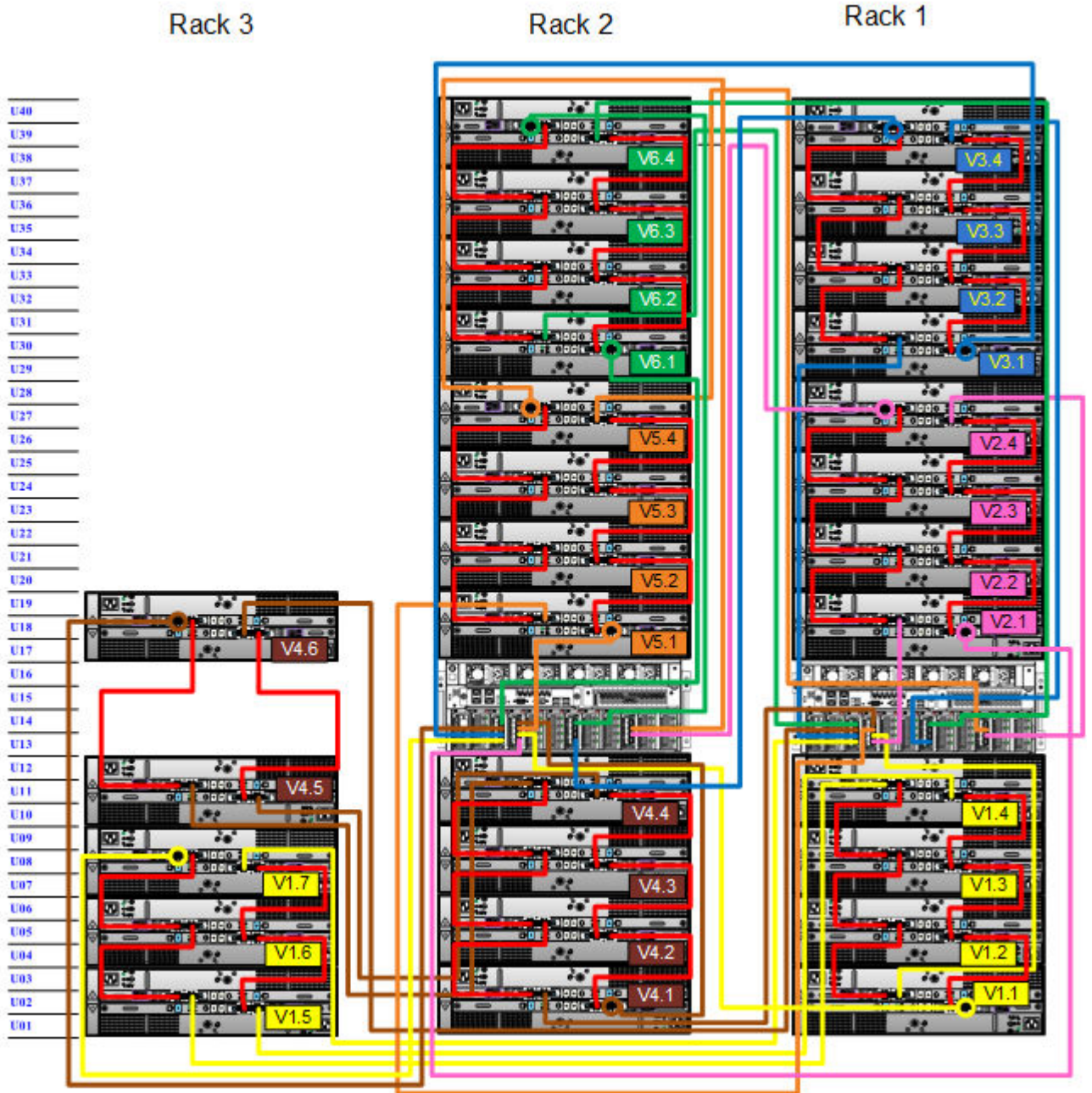


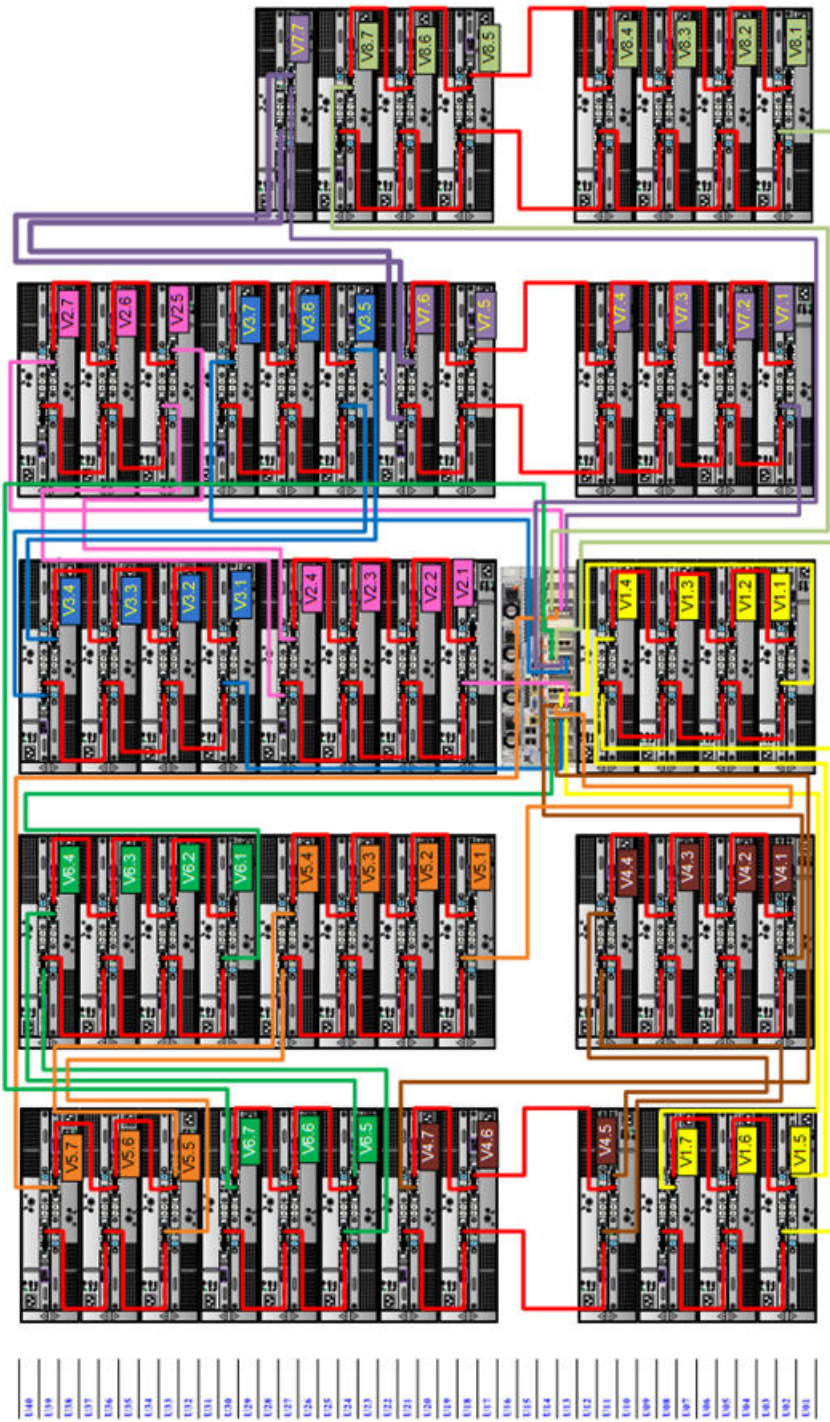
Figure 32 Cabling for HA DD9500 /DD9800 systems in two racks



**Figure 33** Cabling for DD9500 /DD9800 systems with DD Cloud Tier (Single node or HA)



**Figure 34** Cabling for DD9500 /DD9800 systems with ERSO





## Connecting power

For redundant power distribution, use vertical Power Distribution Units (PDUs) on each side of each rack that cover the rack's full height. The power supplies in each chassis are capable of operating on 100-120 VAC or 200-240 VAC, 50 Hz or 60 Hz power.

---

### Note

The voltage used is specific to the site and country of installation.

---

See the Power Calculator to determine total system power requirements: <https://powercalculator.emc.com/PC3/>

- Do not exceed the current capacity of the power distribution unit by adding more products than it can support.
- For safety of personnel and to insure proper functioning of systems, it is recommended that each AC circuit of the power distribution unit have a double pole AC breaker system.

### **CAUTION**

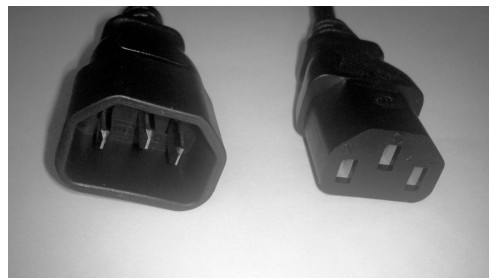
#### **Ensure that the PDU can handle the overall power load.**

---

- The rack's electrical distribution and earth ground bonding must meet the requirements of UL 60950-1 and IEC 60950-1, and local electrical safety building codes.
- The PDUs must have a sufficient quantity of single-phase power outlets with an earth ground conductor (safety ground). A safe electrical earth ground connection must be provided to each power cord.

Each ships with two 1M C13/C14 PDU power cords. The C13 (IEC-60320-C13) side connects to the power supply, and the C14 (IEC-60320-C14) side connects to most PDUs.

**Figure 35** C14 (left) and C13 (right) power cords



## Attaching the power supplies

### Procedure

1. Install the Data Domain controller and the ES30 shelves in the rack or racks with the PDUs.
2. Cable the expansion shelves to the controller and to each other as described in [Shelf cabling rules and guidelines](#) on page 21.

3. Ensure the rack is grounded before connecting AC power from the main circuit.
4. To ensure redundant AC power, connect each power supply of the ES30 to a different AC circuit. If the ES30 is to be connected to PDUs, then each power supply of the ES30 must be fed from a different PDU, and each PDU must be connected to a separate AC circuit.
5. Attach the power supplies on the rear panel of the Data Domain controller to separate PDUs for redundant power distribution, one on each side of the rack.
6. The ES30 powers on immediately after you attach one of the power supplies on the rear panel of the ES30 shelf to a PDU with power.
7. If multiple racks are used, complete the cabling of all shelves in all racks before applying power.

## Types of cabinets and power connections

The ES30 chassis is installed in two types of racks: 40U-C (existing racks) and the 40U-P (newer racks). The racks use one phase or 3 phase power connections.

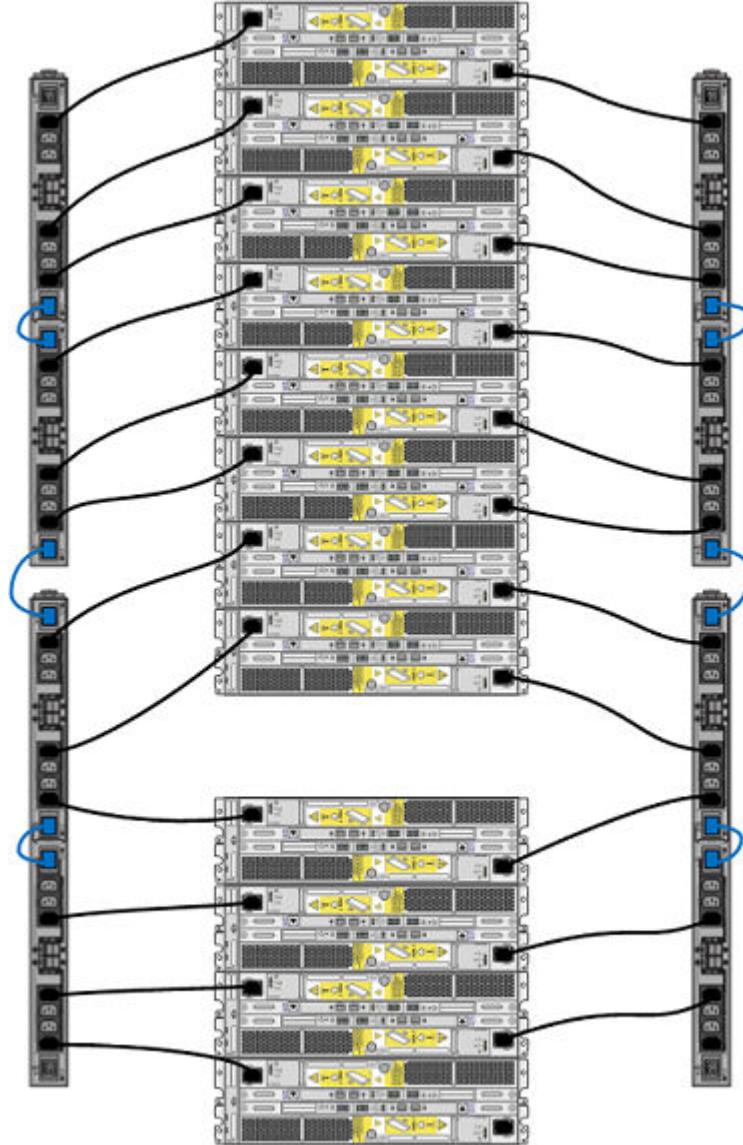
This section describes the different types of racks and the power connections for the ES30 chassis.

- [Single phase power connections for 40U-P \(current racks\)](#) on page 75
- [Single phase power connections for 40U-C \(older racks\)](#) on page 83
- [3-Phase power connections for 40U-P \(current racks\)](#) on page 87
- [3-Phase power connections for 40U-C \(older racks\)](#) on page 106

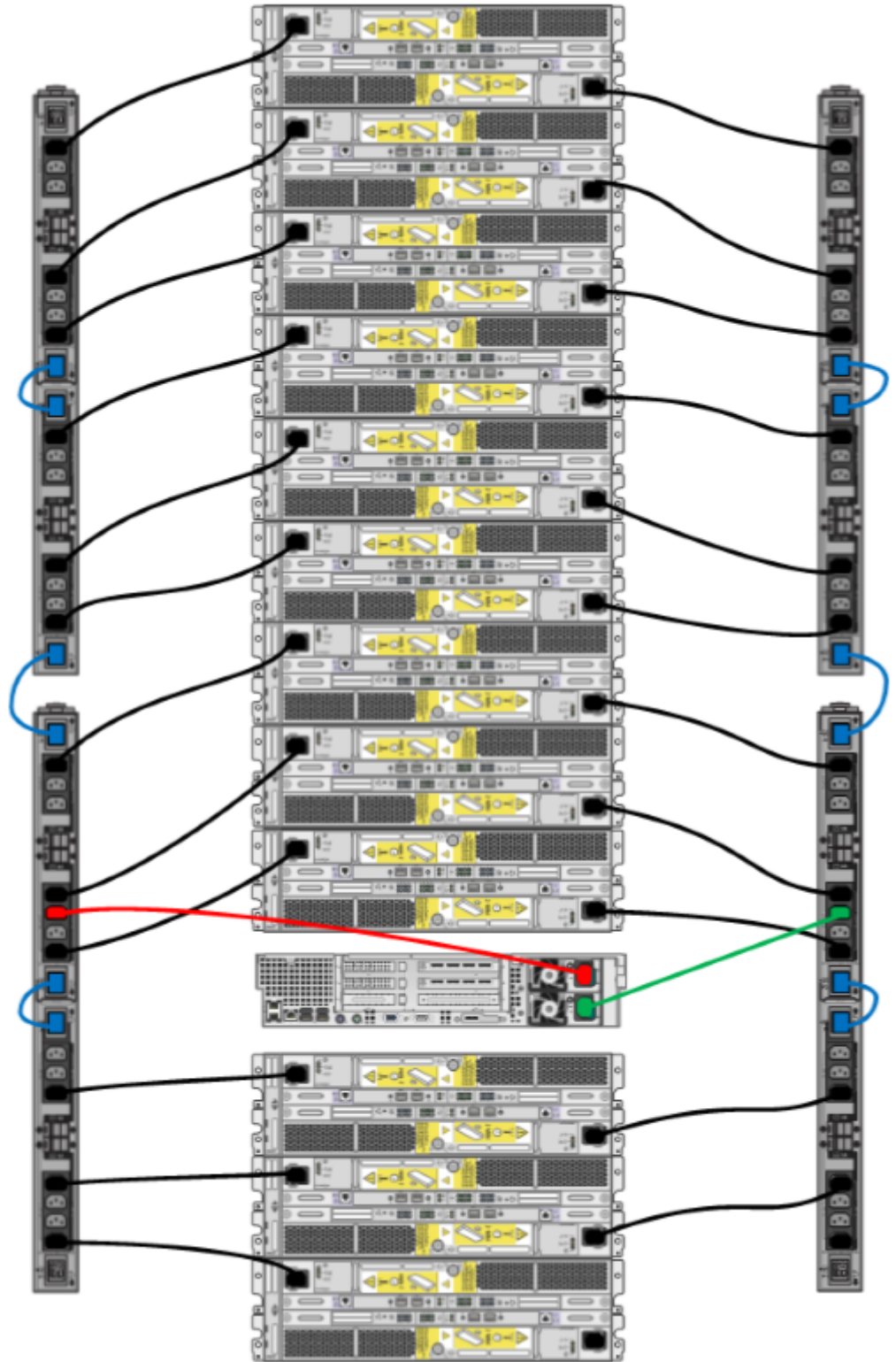
## Single phase power connections for 40U-P (current racks)

The following figures show single phase power connections for 40U-P racks used for several Data Domain systems.

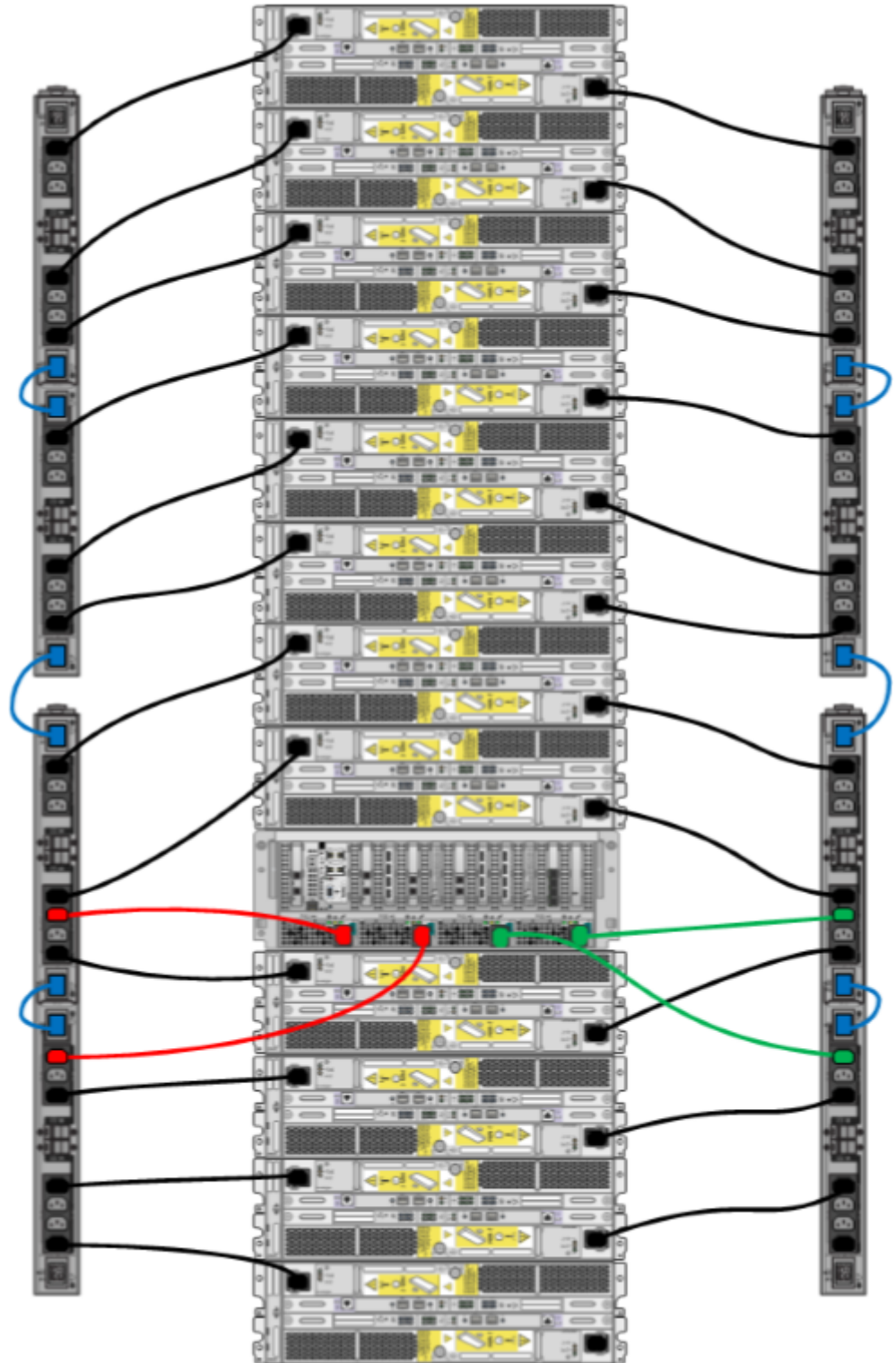
**Figure 36** Recommended single phase power connections for the 40U-P expansion rack



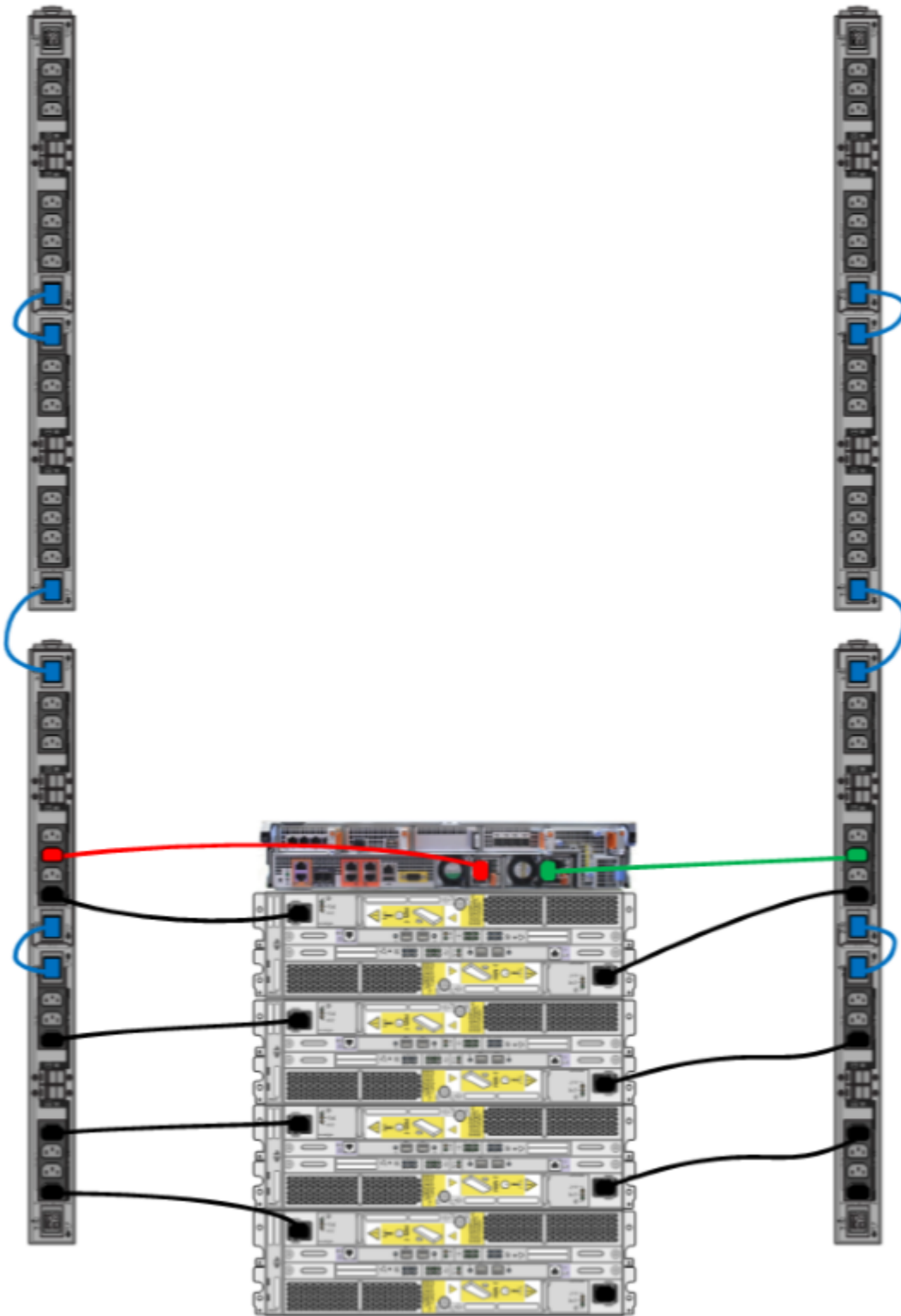
**Figure 37** Recommended single phase power connections for the DD860 and DD890



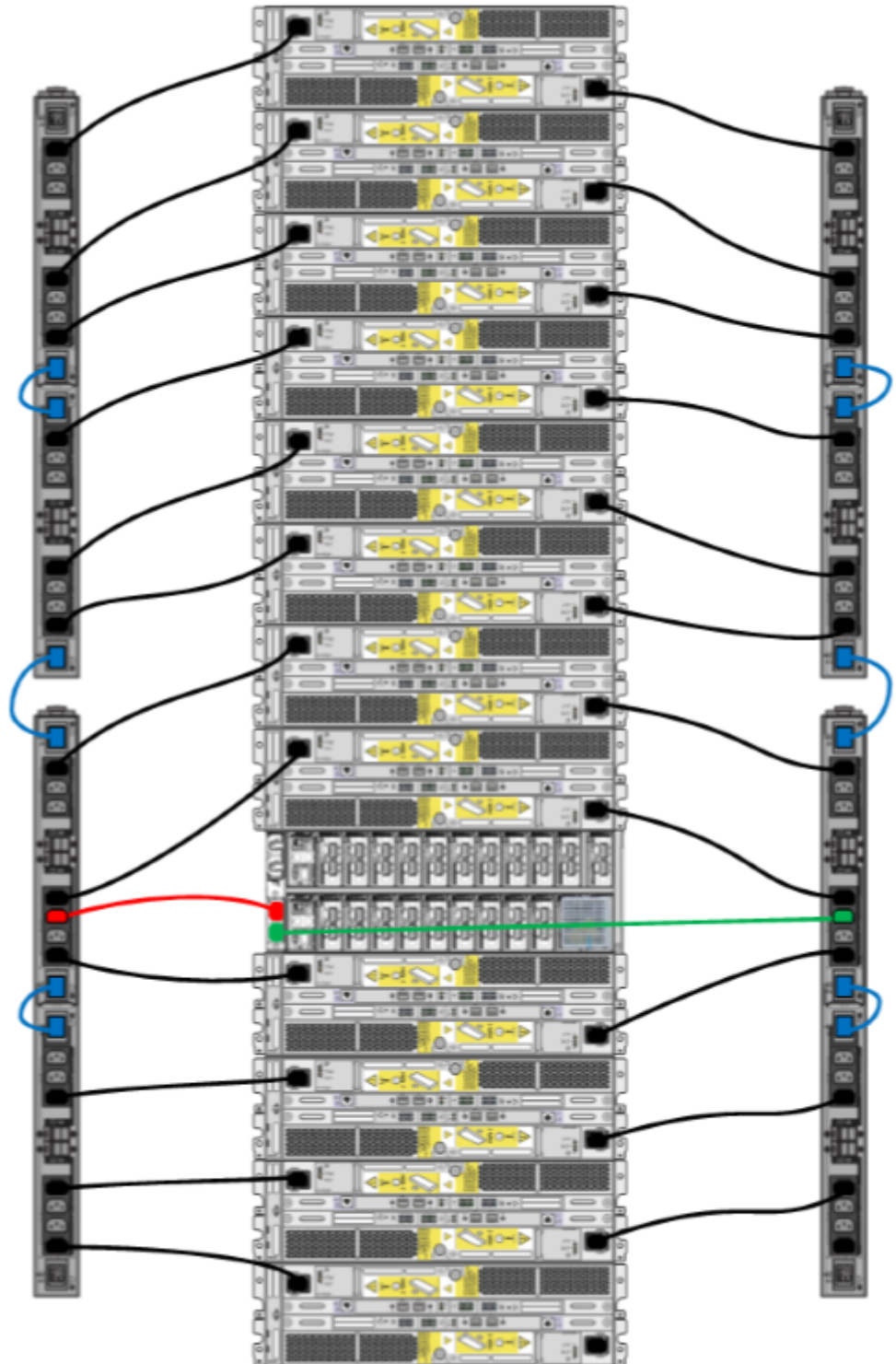
**Figure 38** Recommended single phase power connections for the DD990



**Figure 39** Recommended single phase power connections for the DD2500



**Figure 40** Recommended single phase power connections for the DD4200, DD4500, and DD7200



**Figure 41** Recommended single phase power connections for DD6300, DD6800 and DD9300

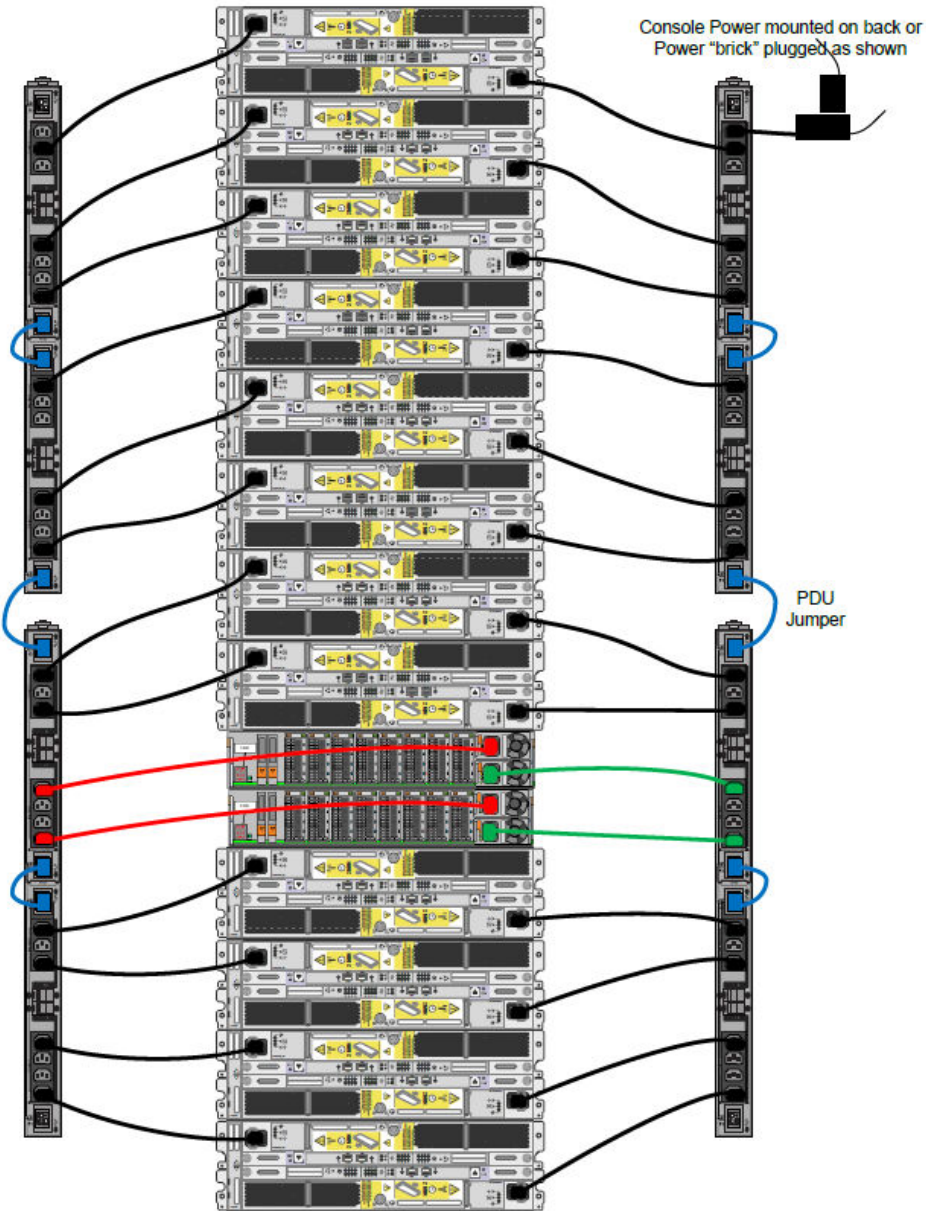
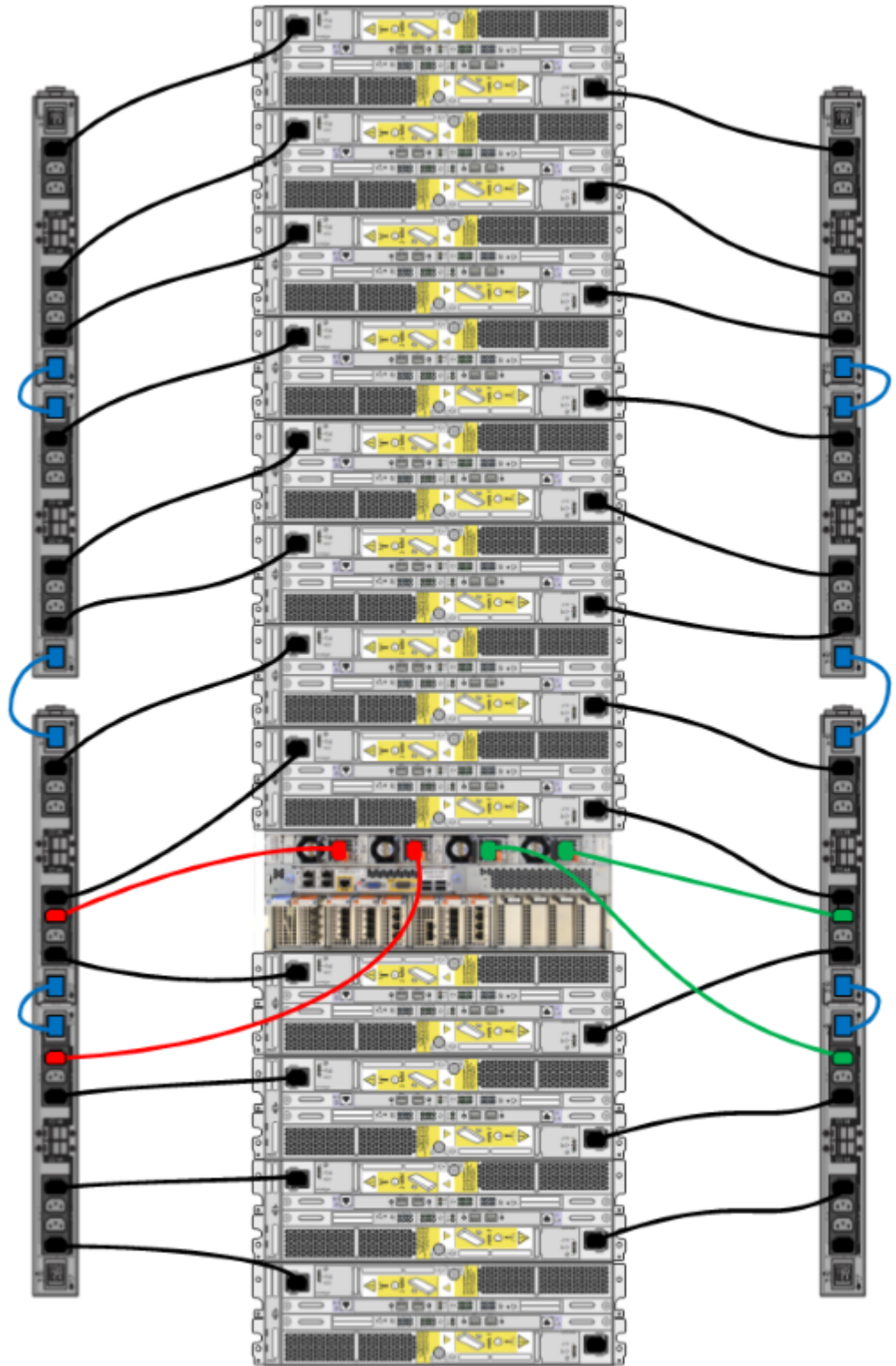
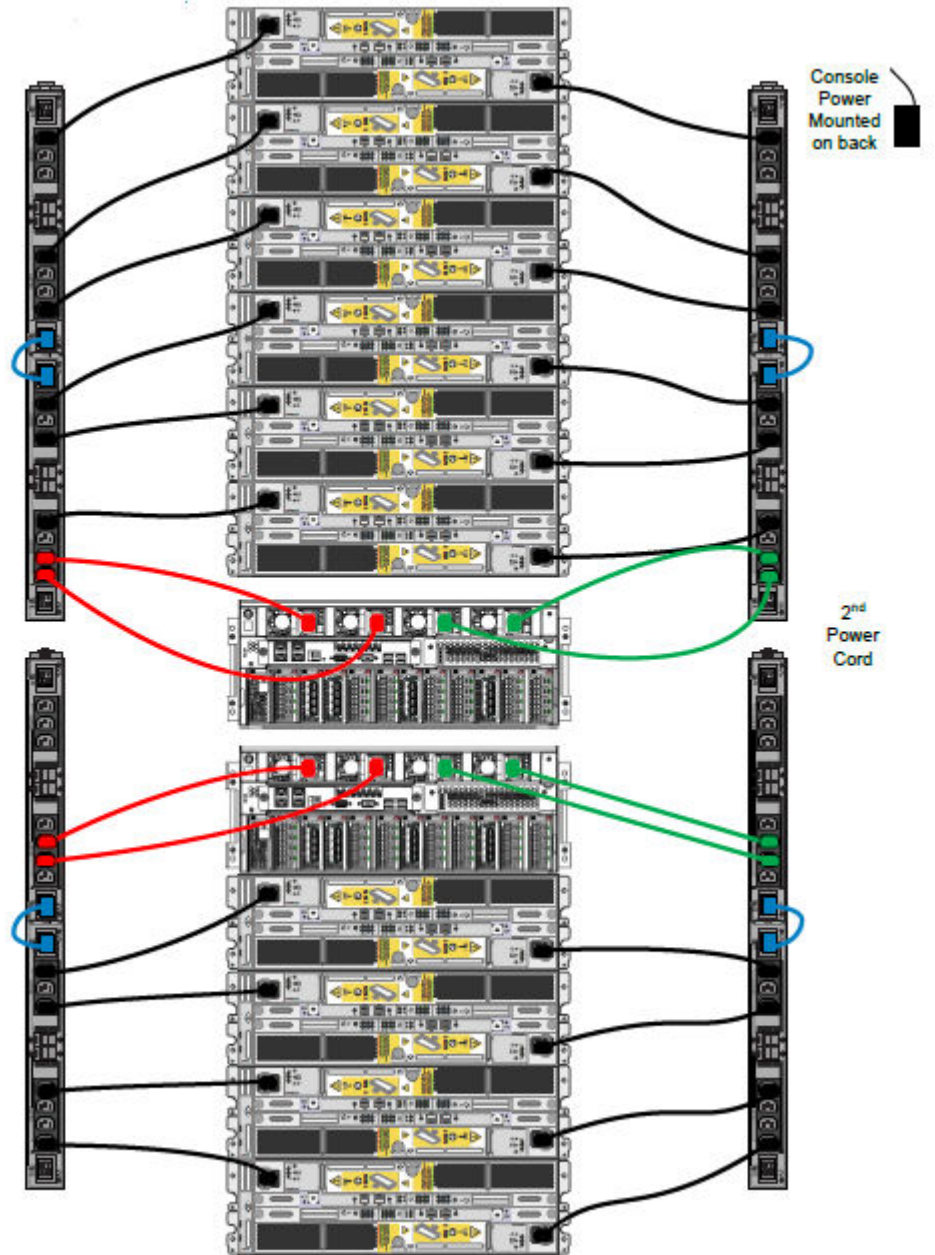




Figure 42 Recommended single phase power connections for the DD9500/DD9800



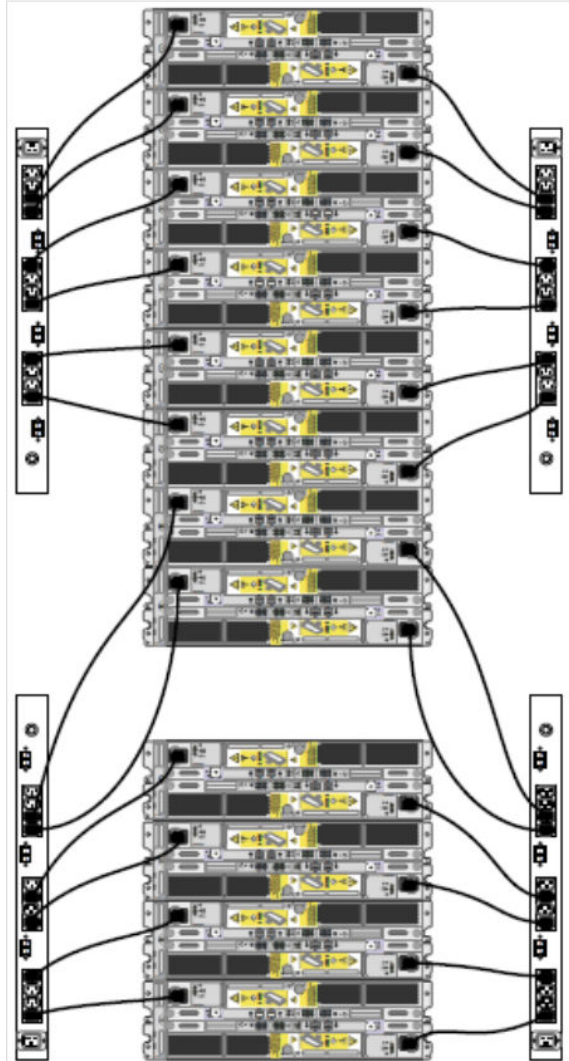
**Figure 43** Recommended single phase power connections for the DD9500 HA



## Single phase power connections for 40U-C (older racks)

The following figures show single phase power connections for 40U-C racks used for several Data Domain systems.

**Figure 44** Recommended single phase power connections for the Expansion Rack



**Figure 45** Recommended single phase power connections for a DD860 and DD890

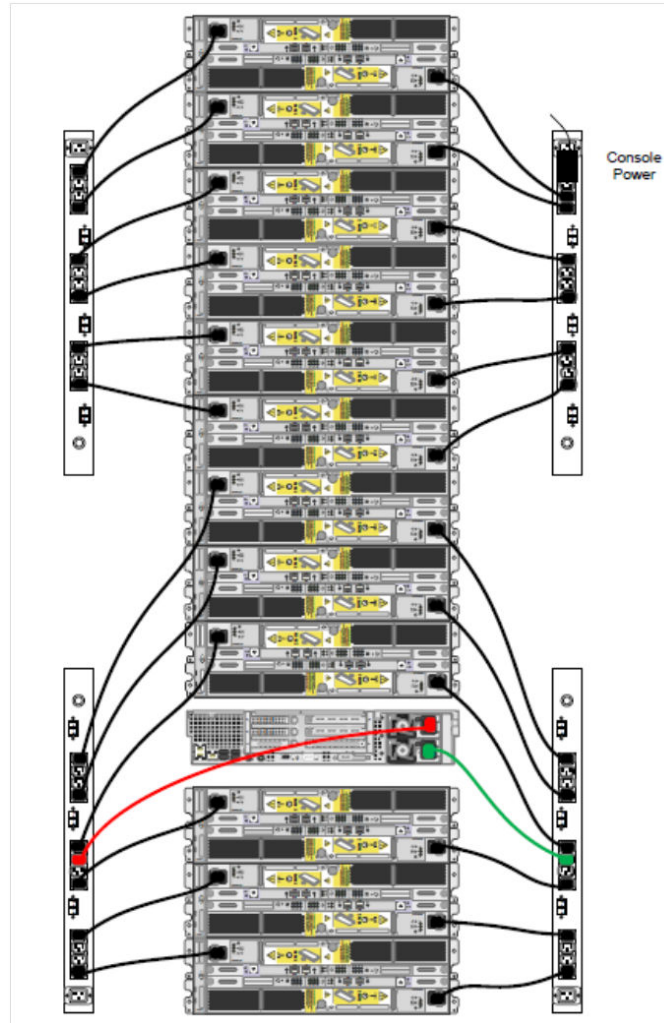
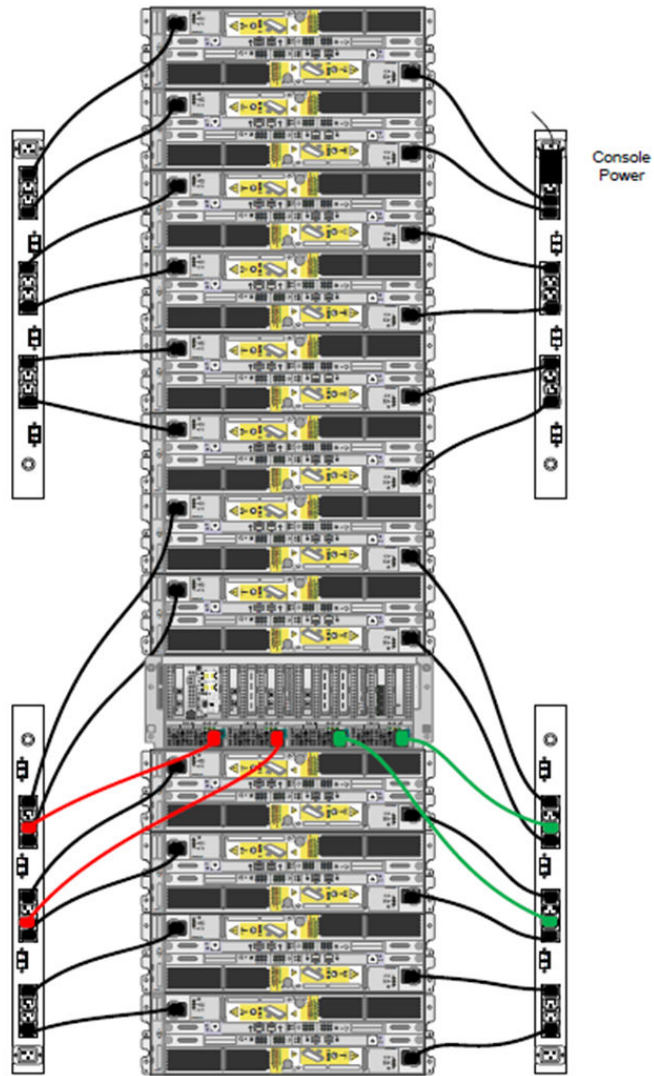
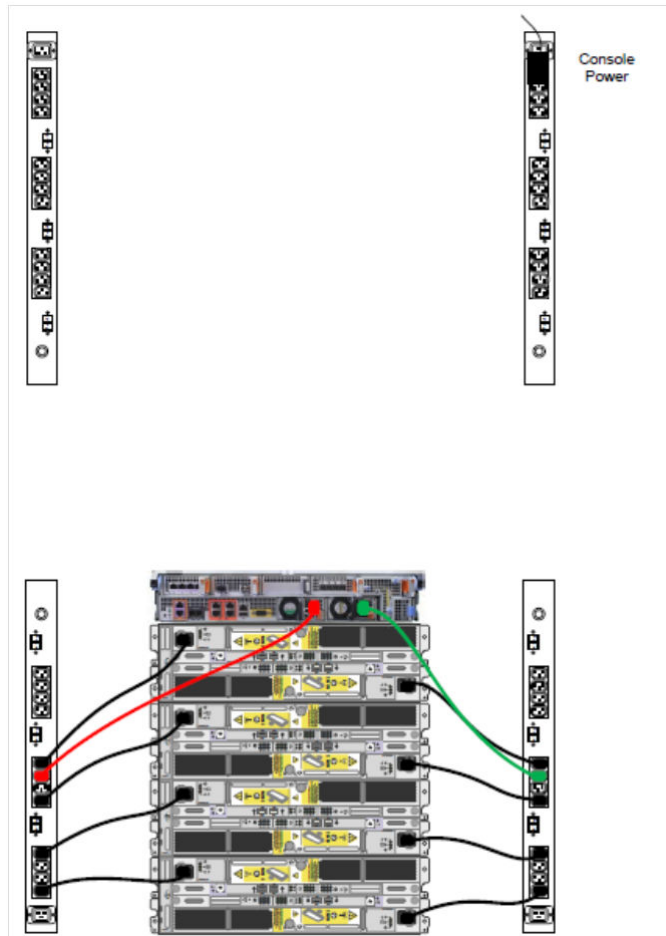


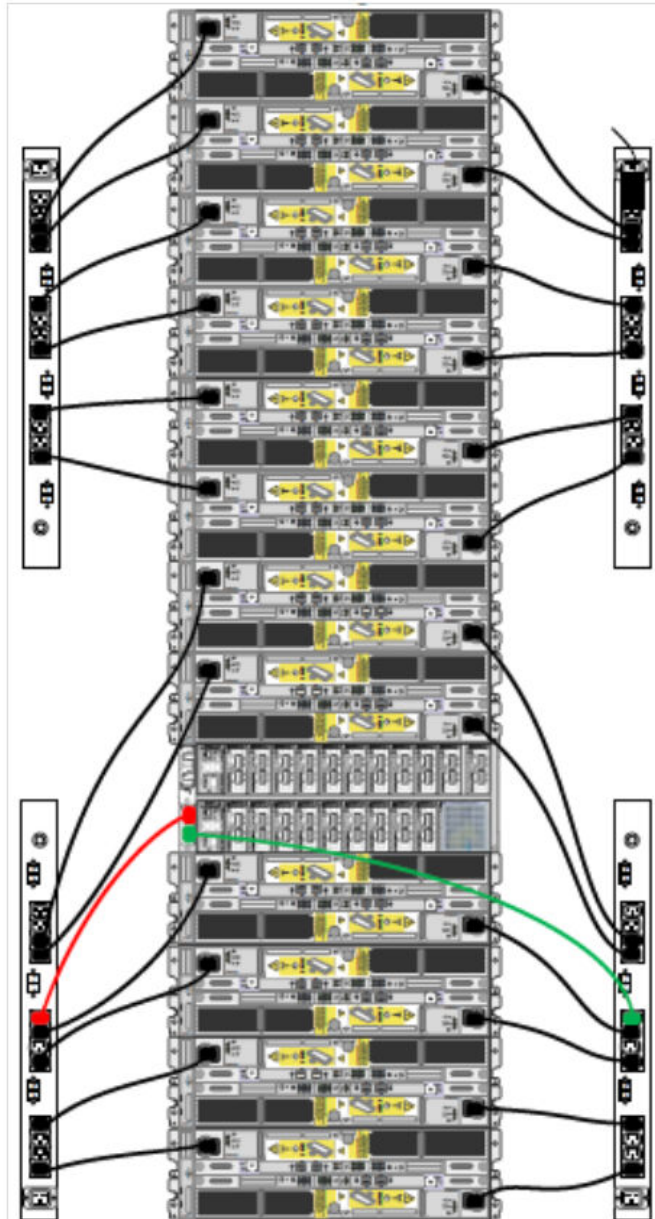
Figure 46 Recommended single phase power connections for the DD990



**Figure 47** Recommended single phase power connections for the DD2500



**Figure 48** Recommended single phase power connections for the DD4200, DD4500, and DD7200



### 3-Phase power connections for 40U-P (current racks)

Some environments use 3-phase power for 40U-P racks used for several Data Domain systems. In those situations it is desirable to balance the current draw across all 3 phases. The recommended 3-phase power cabling attempts to do that, but an optimal configuration is dependent on the specific installation. The following figures show recommended 3-phase power connections for several Data Domain systems.

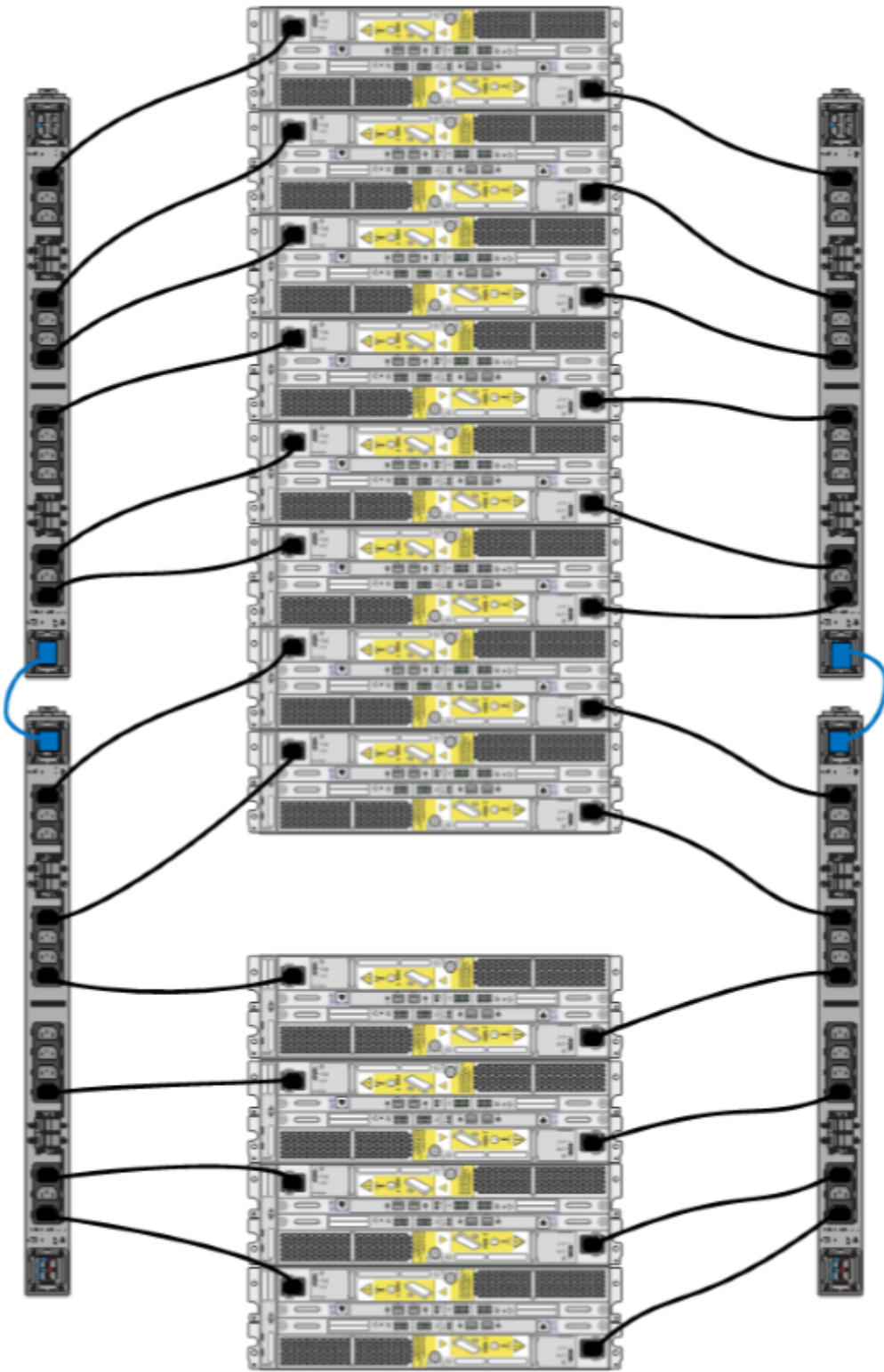
---

#### Note

The next few diagrams show recommended 3-phase delta power connections.

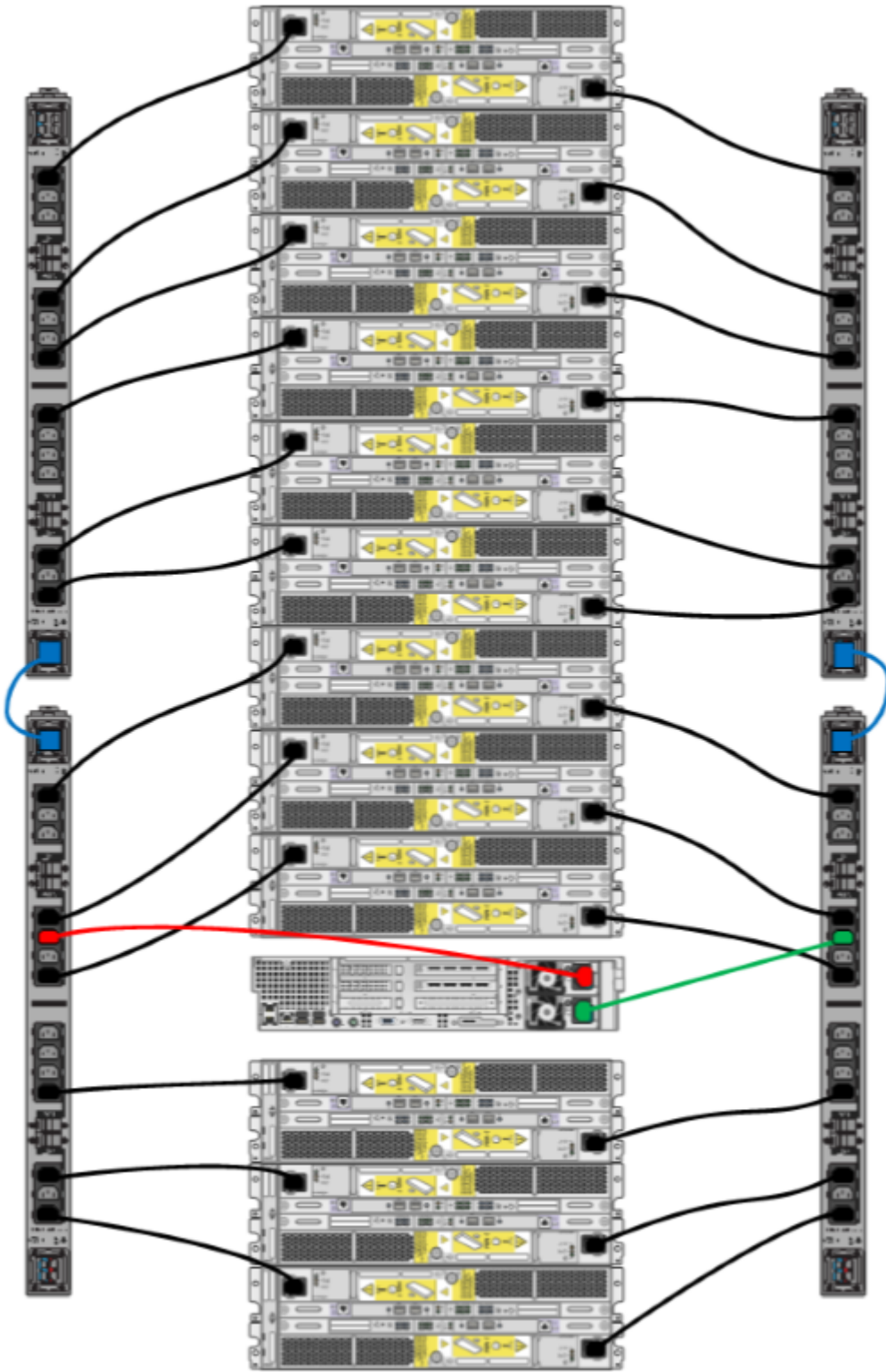
---

**Figure 49** Recommended 3-phase delta power connections for the Expansion Rack





**Figure 50** Recommended 3-phase delta power connections for DD860 and DD890



**Figure 51** Recommended 3-phase delta power connections for DD860 with Extended Retention

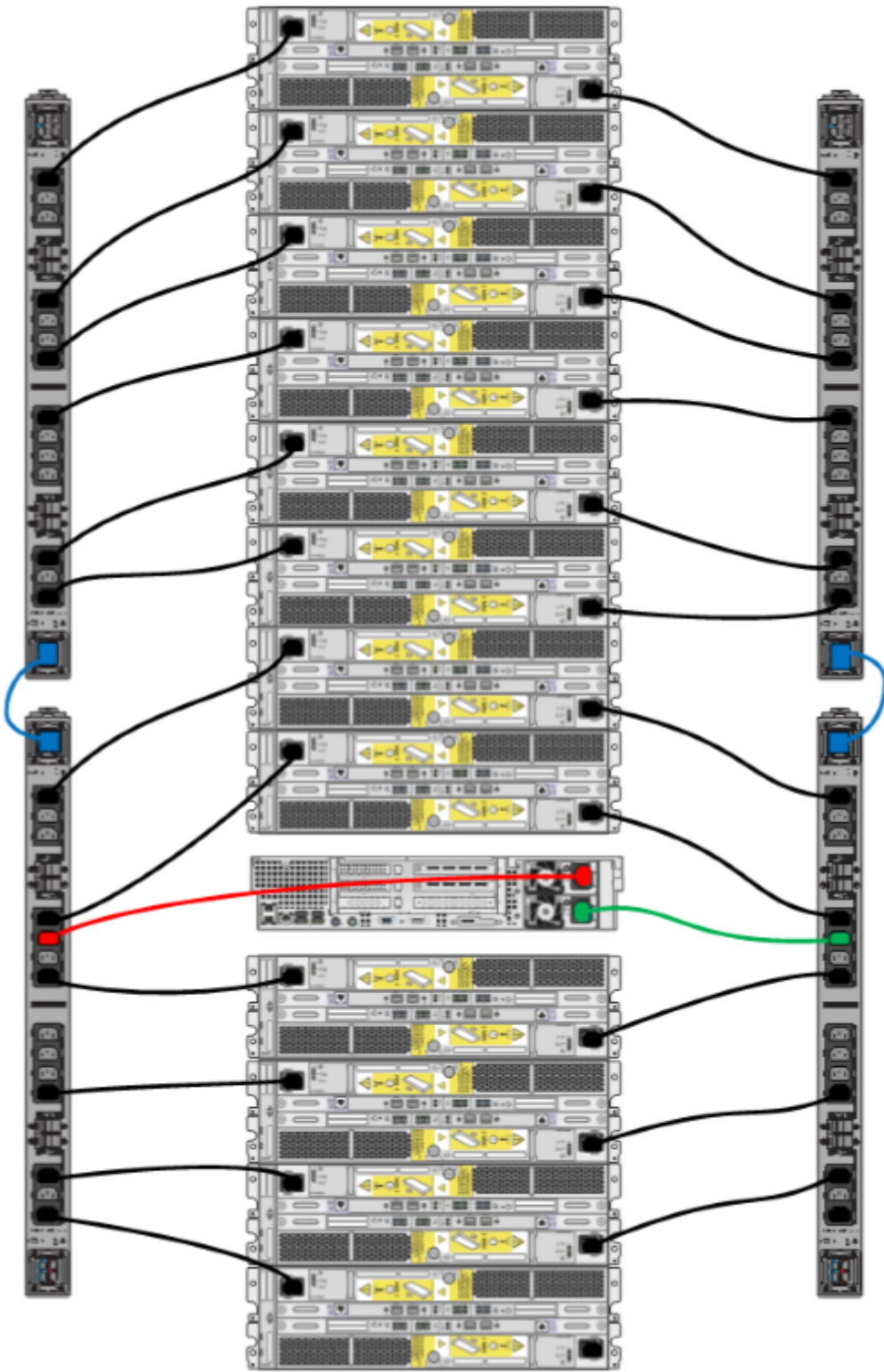
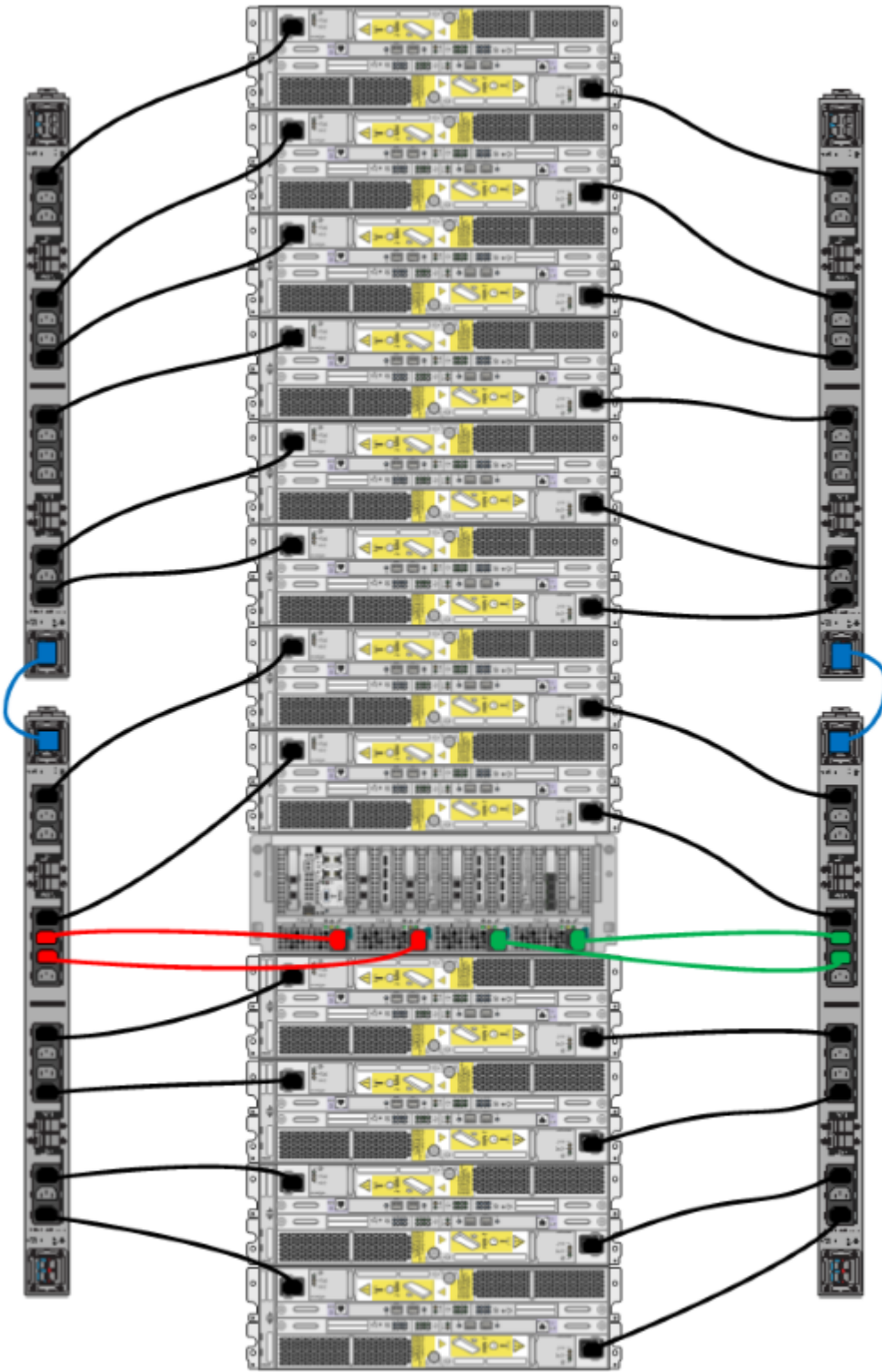
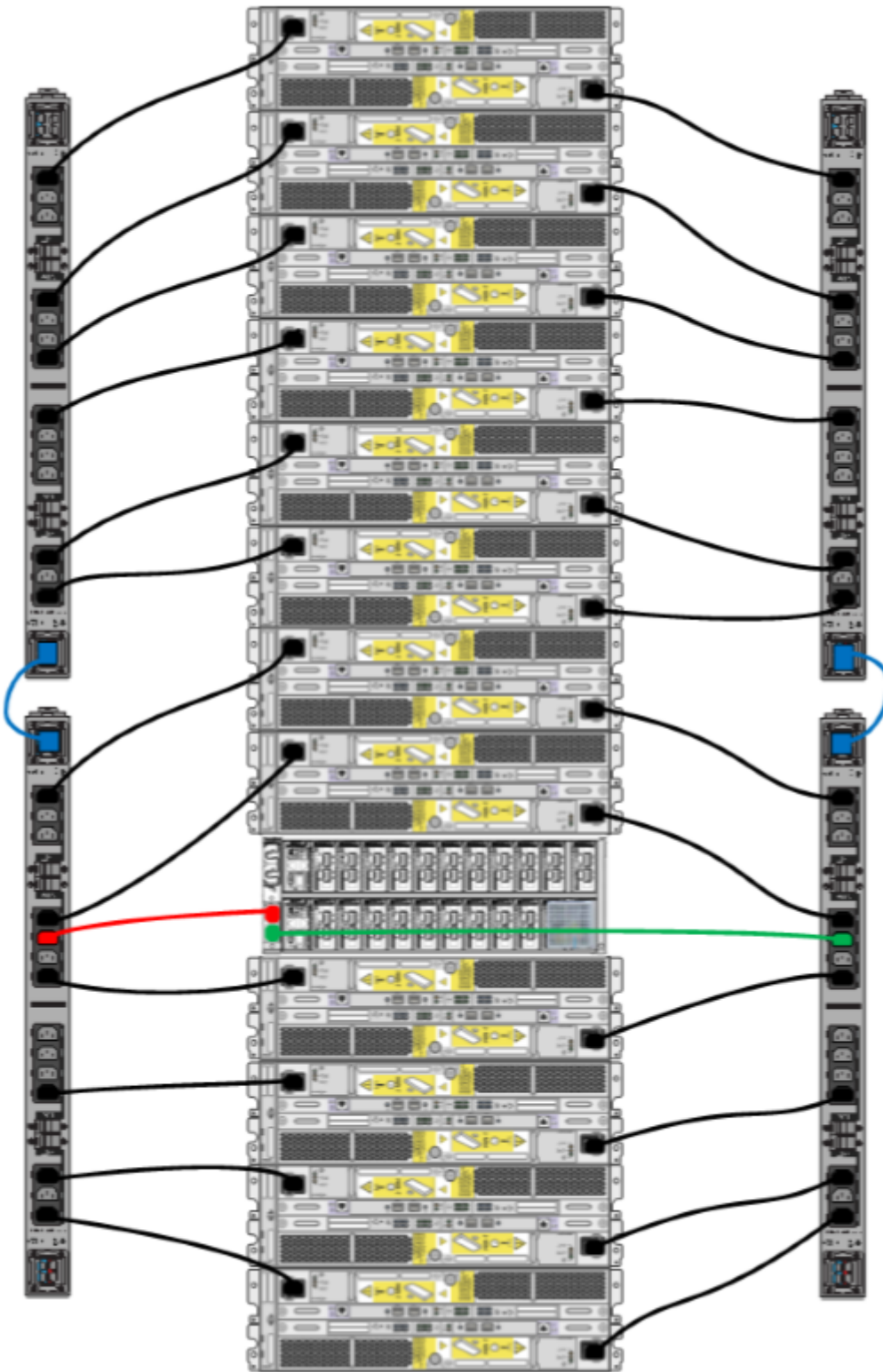


Figure 52 Recommended 3-phase delta power connections for DD990



**Figure 53** Recommended 3-phase delta power connections for DD4200, DD4500, and DD7200



**Figure 54** Recommended 3-phase delta power connections for DD2500

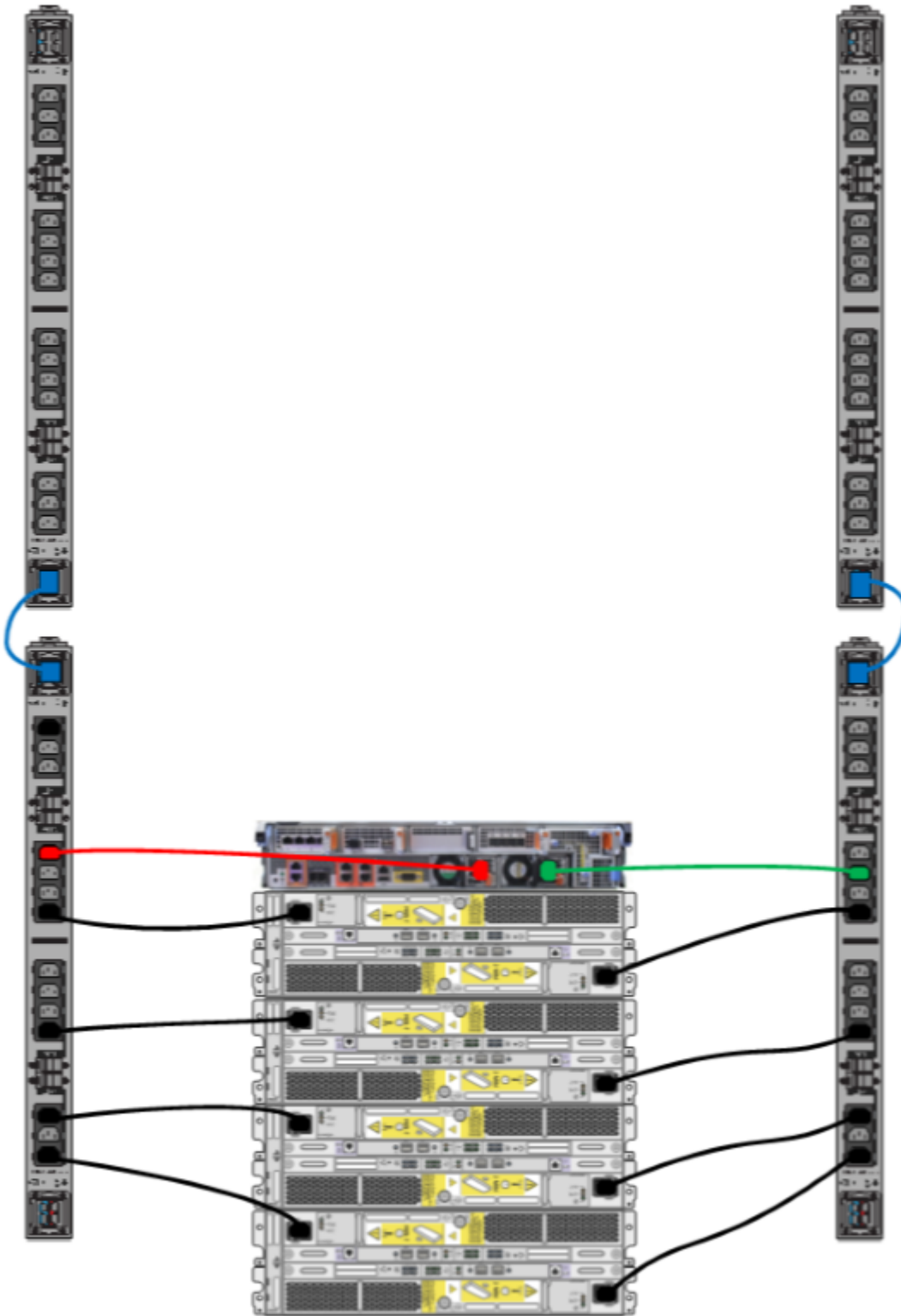
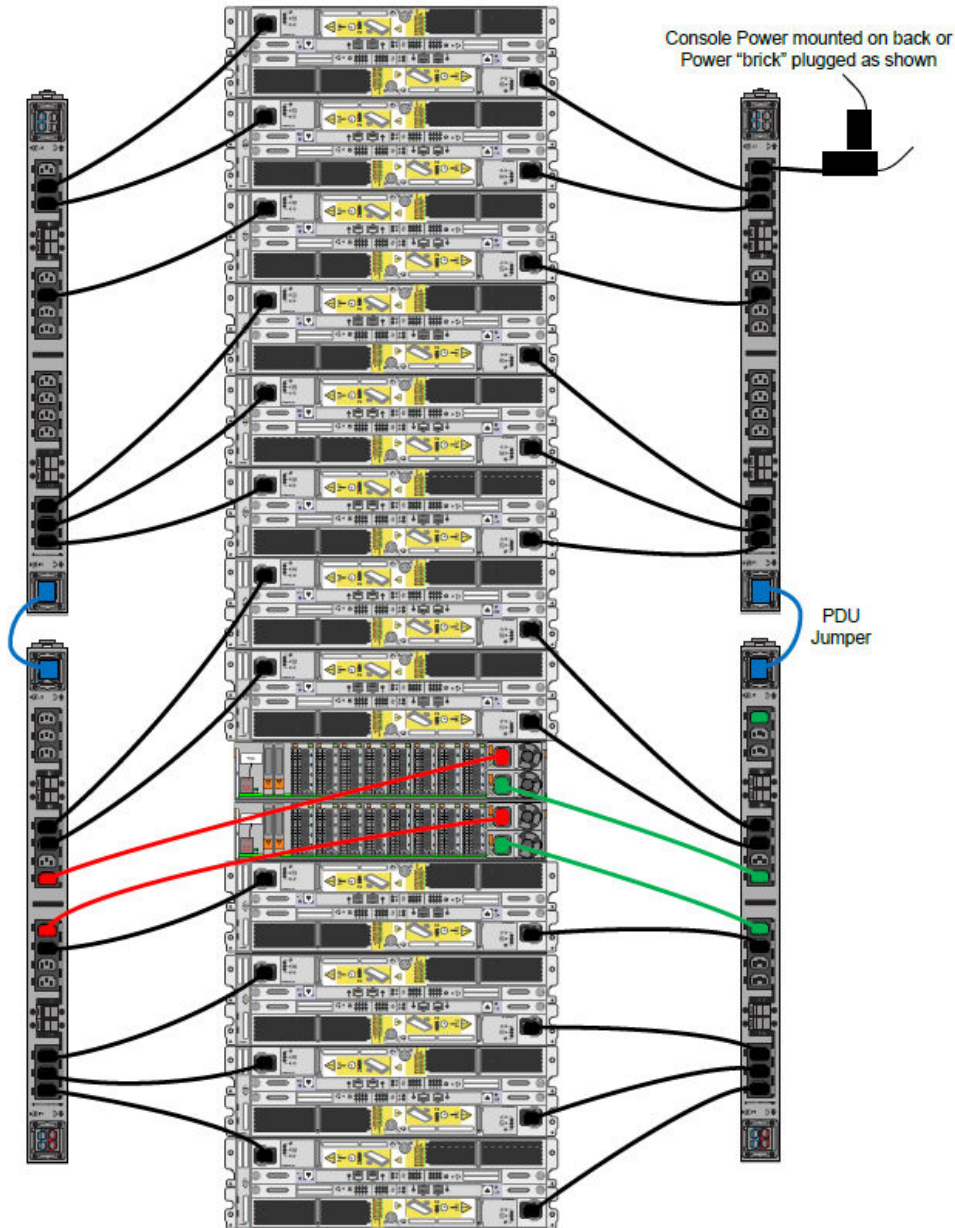


Figure 55 Recommended 3-phase delta power connections for DD6300, DD6800 and DD9300



**Figure 56** Recommended 3-phase delta power connections for DD9500/DD9800

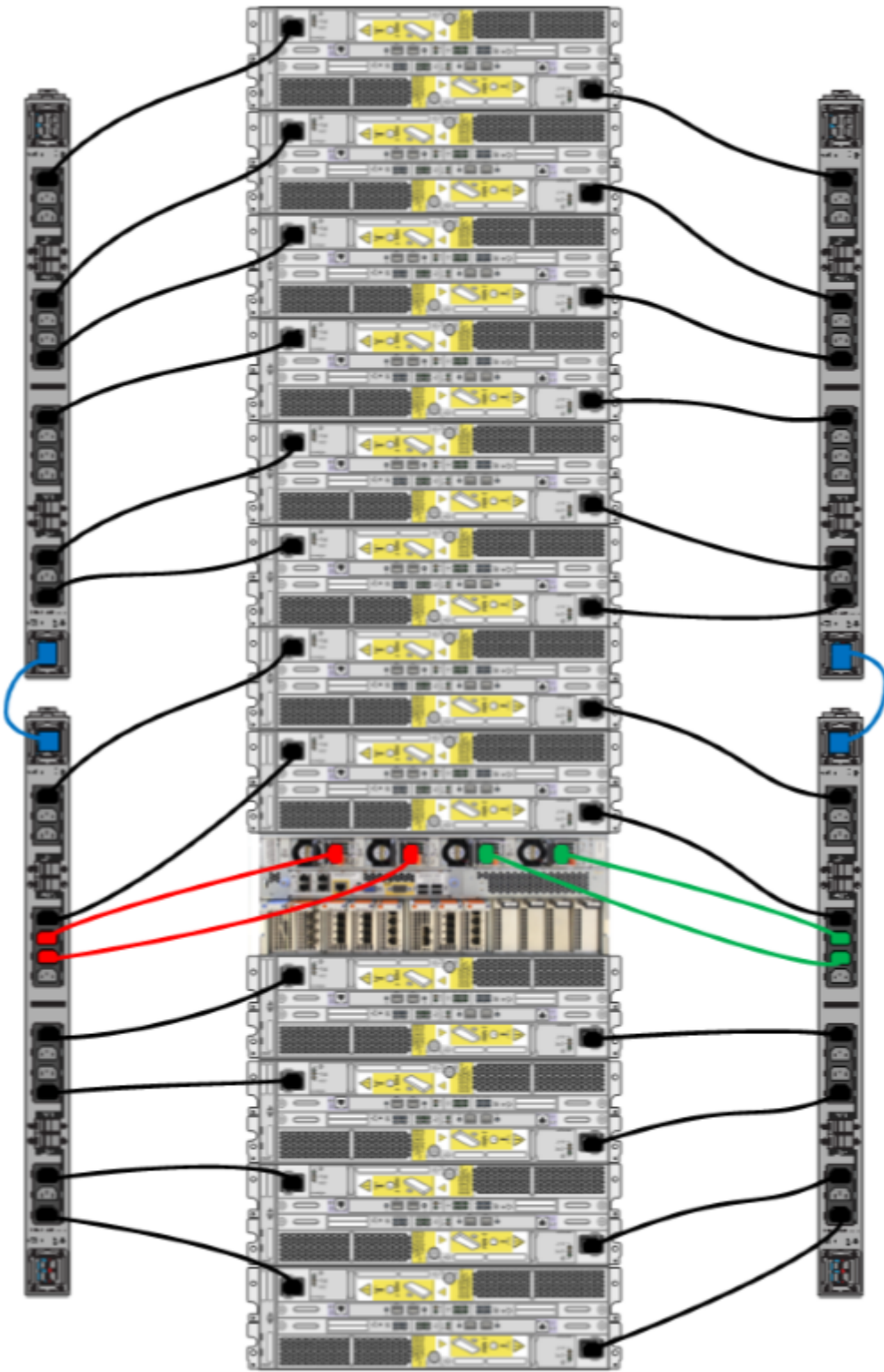
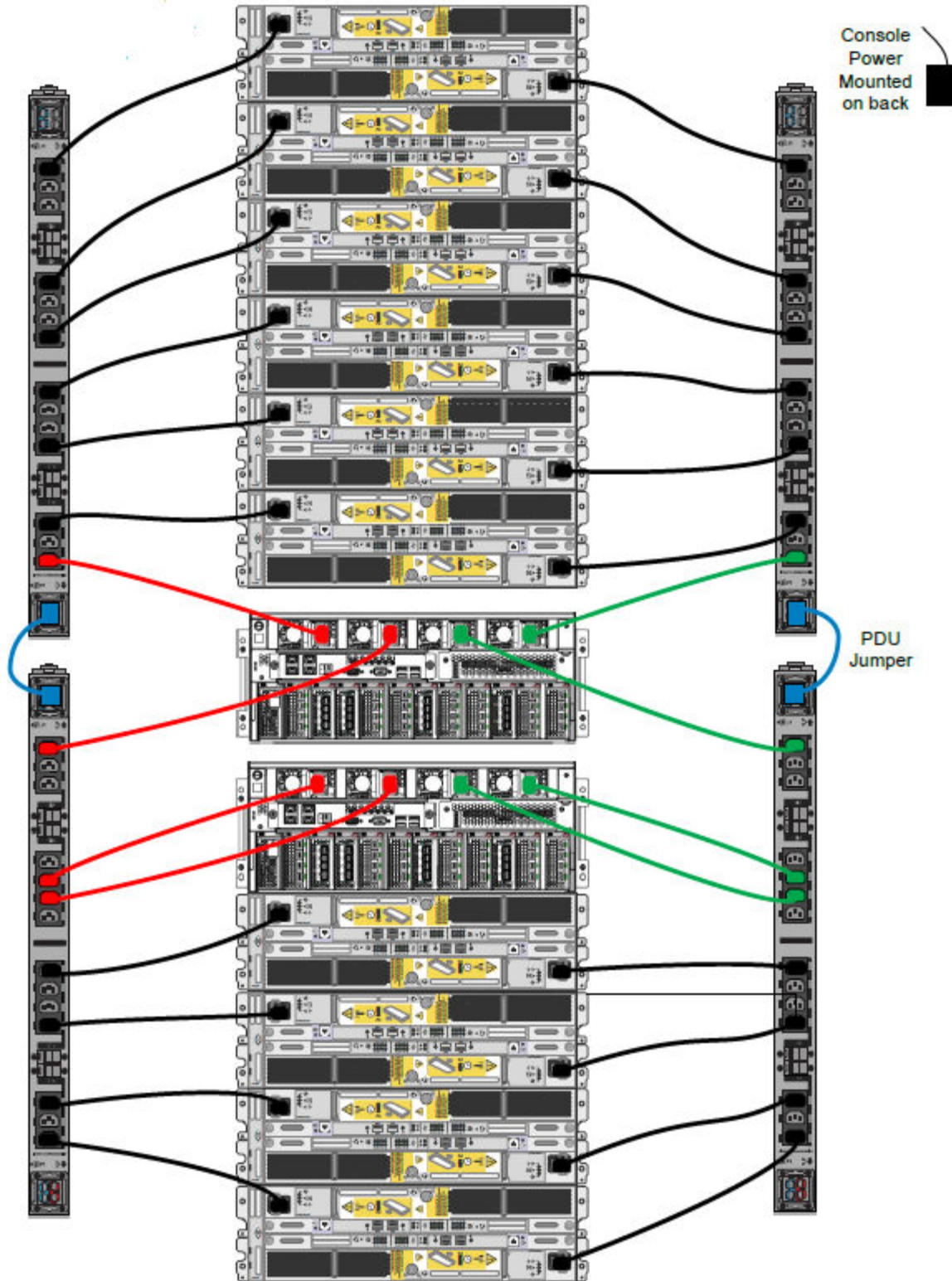


Figure 57 Recommended 3-phase delta power connections for DD9500/DD9800 HA





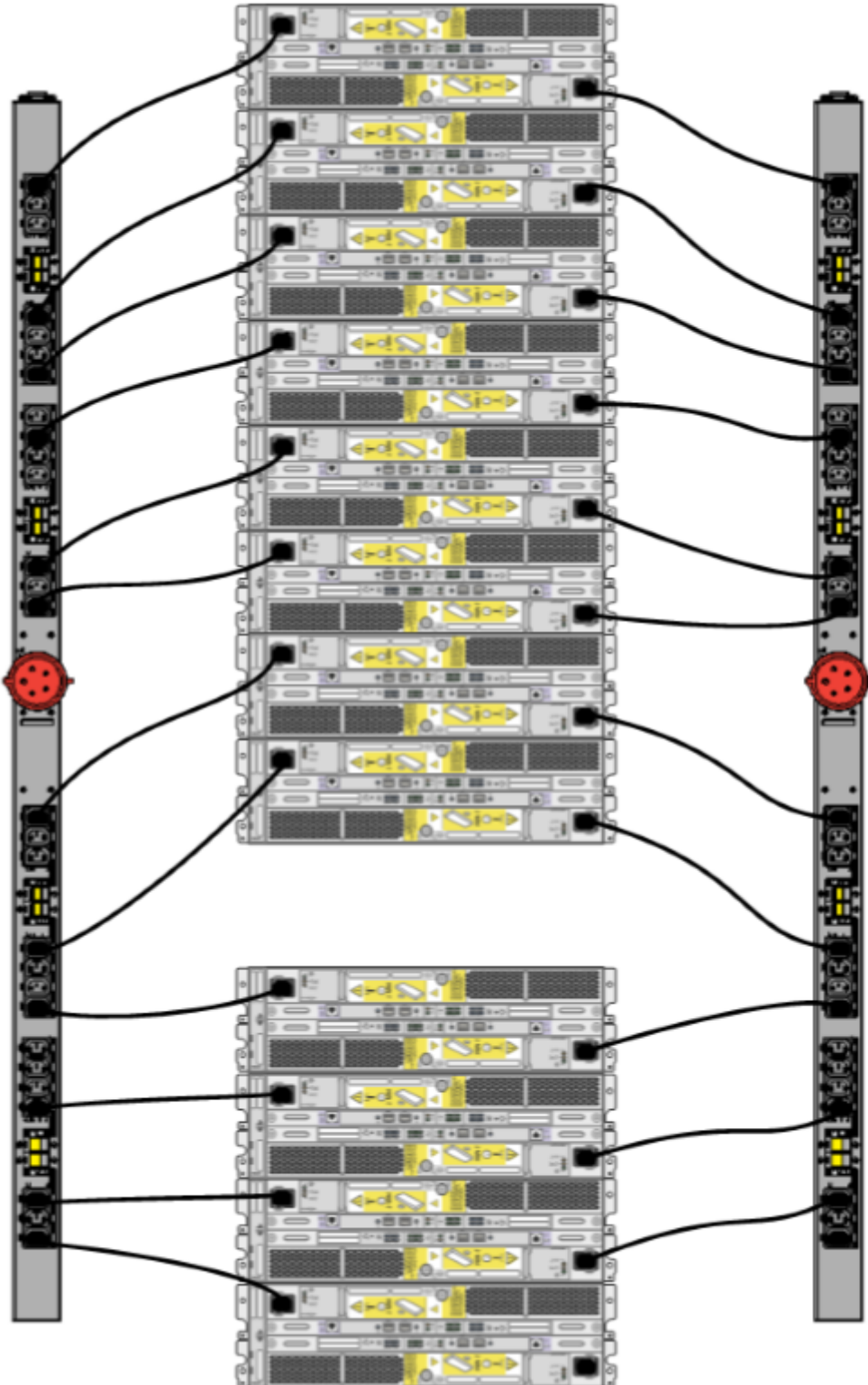
---

**Note**

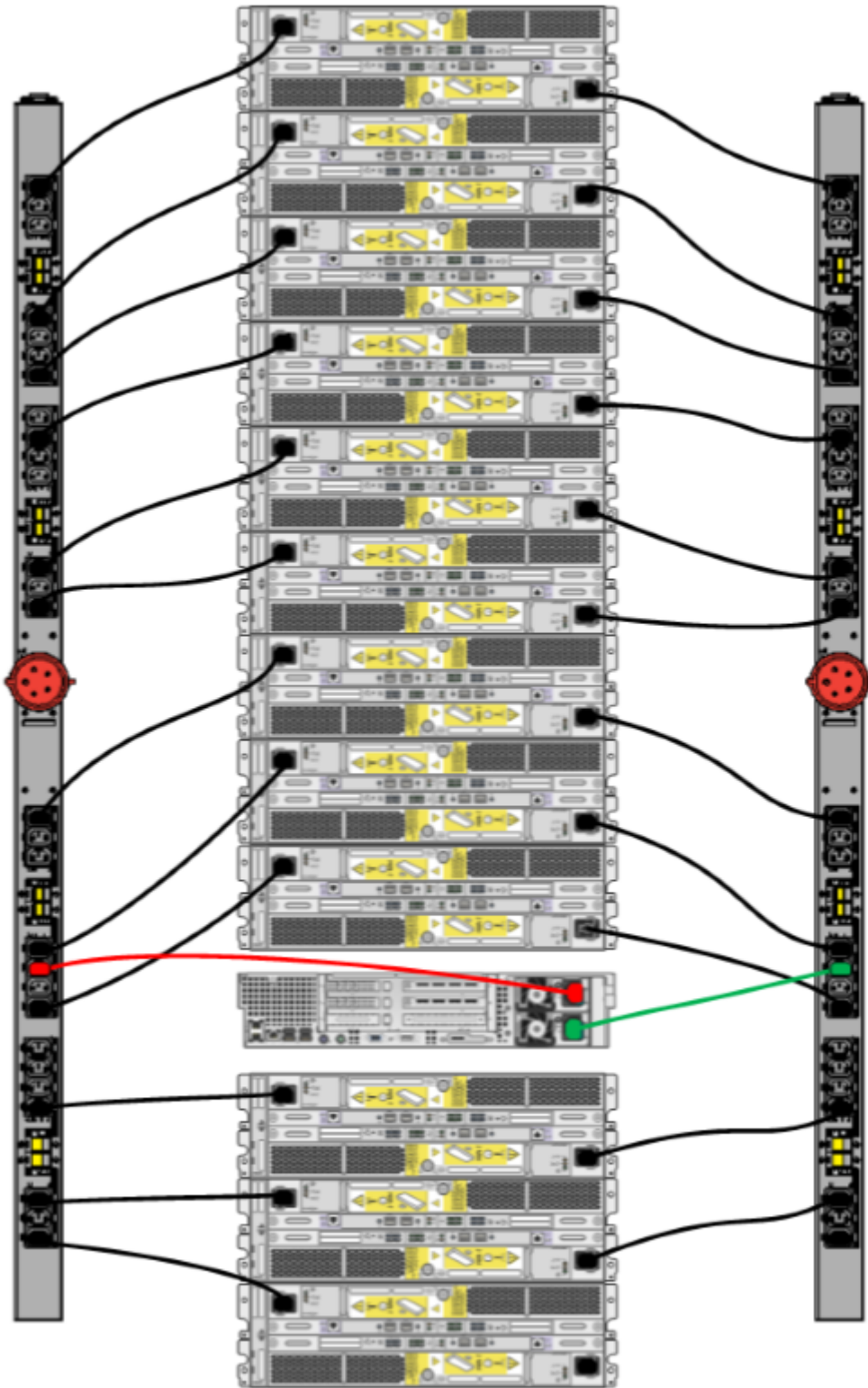
The next few diagrams show recommended 3-phase wye power connections.

---

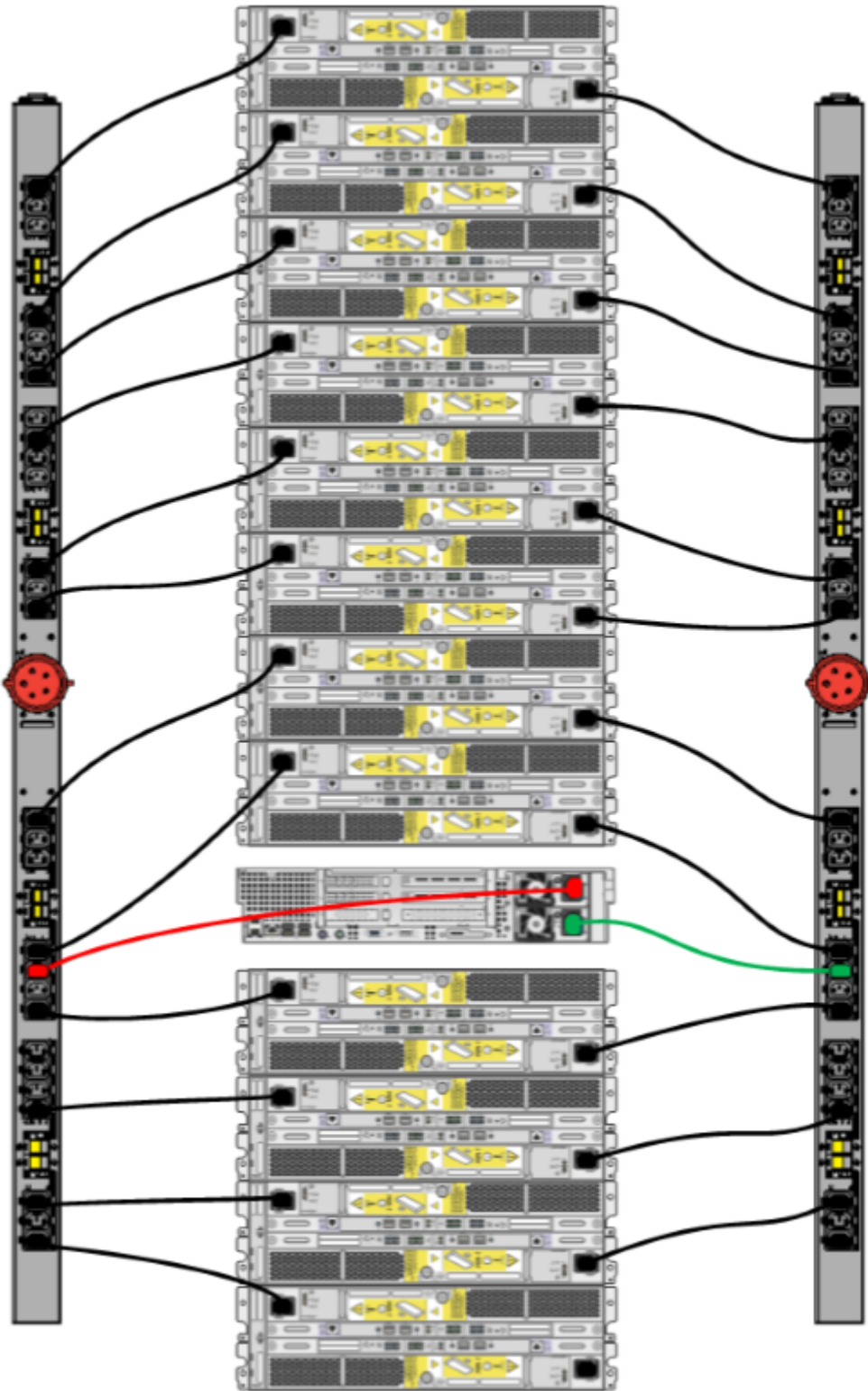
**Figure 58** Recommended 3-phase wye power connections for the Expansion Rack



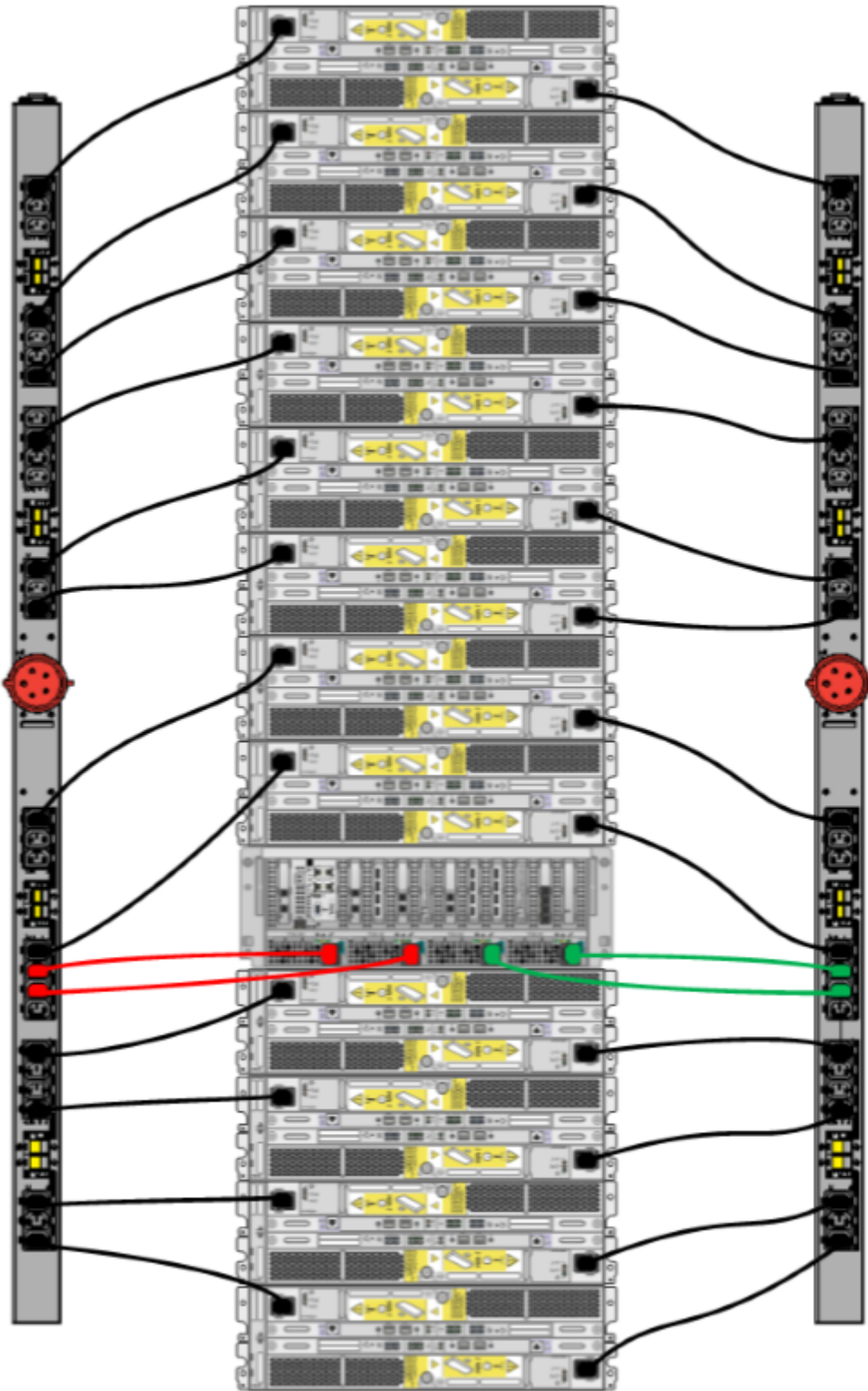
**Figure 59** Recommended 3-phase wye power connections for DD860 and DD890



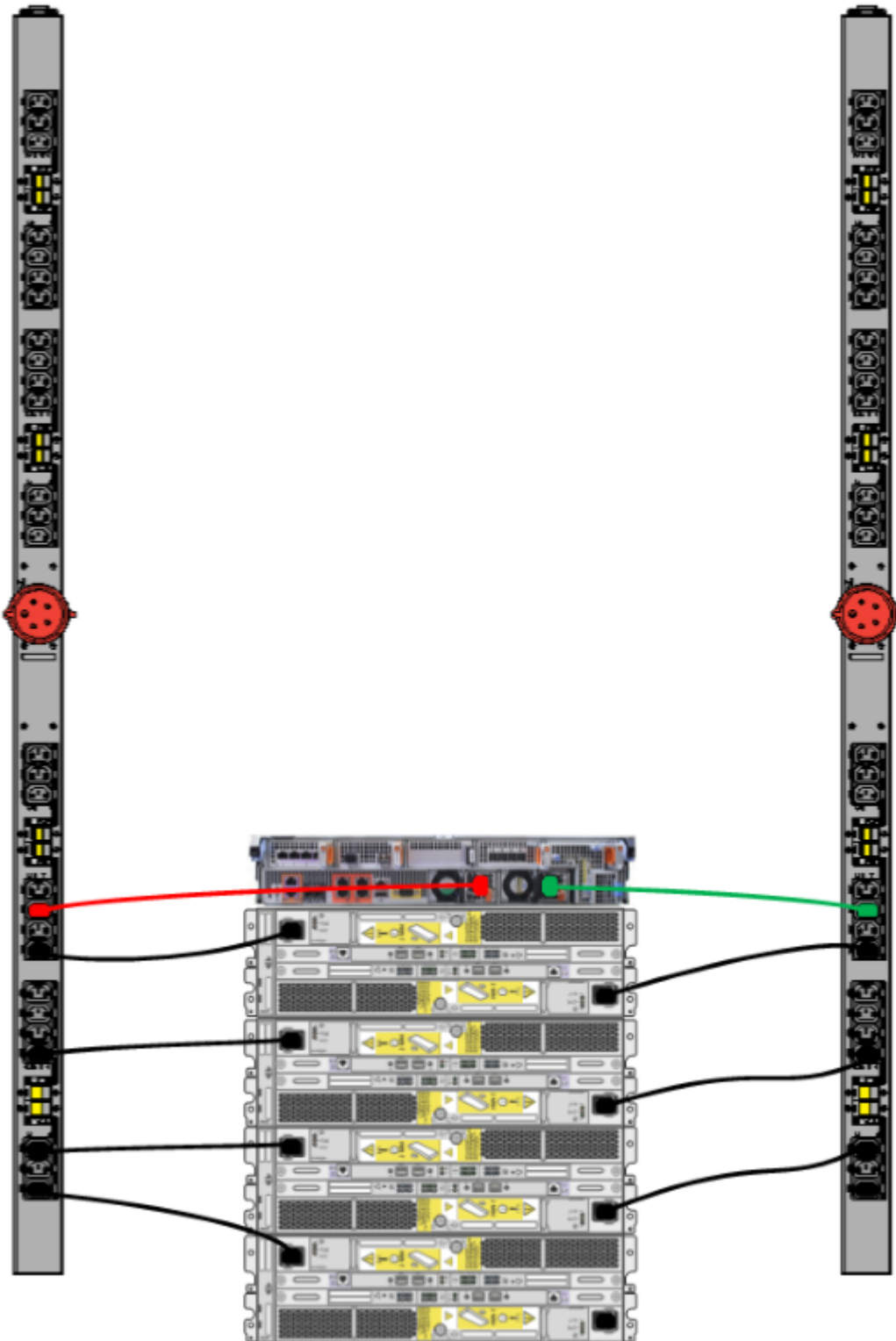
**Figure 60** Recommended 3-phase wye power connections for DD860 with Extended Retention



**Figure 61** Recommended 3-phase wye power connections for DD990



**Figure 62** Recommended 3-phase wye power connections for DD2500



**Figure 63** Recommended 3-phase wye power connections for DD4200, DD4500, and DD7200

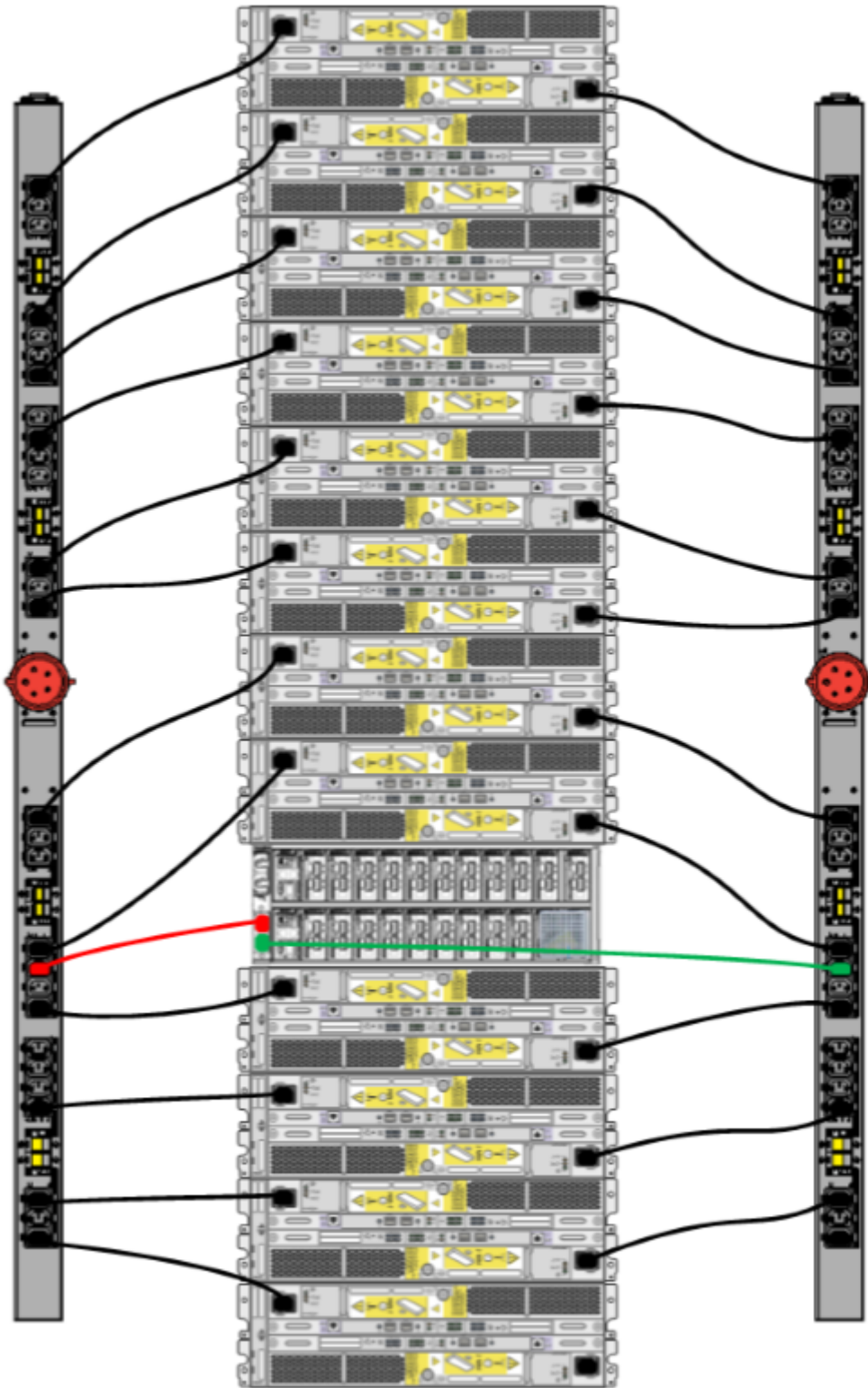
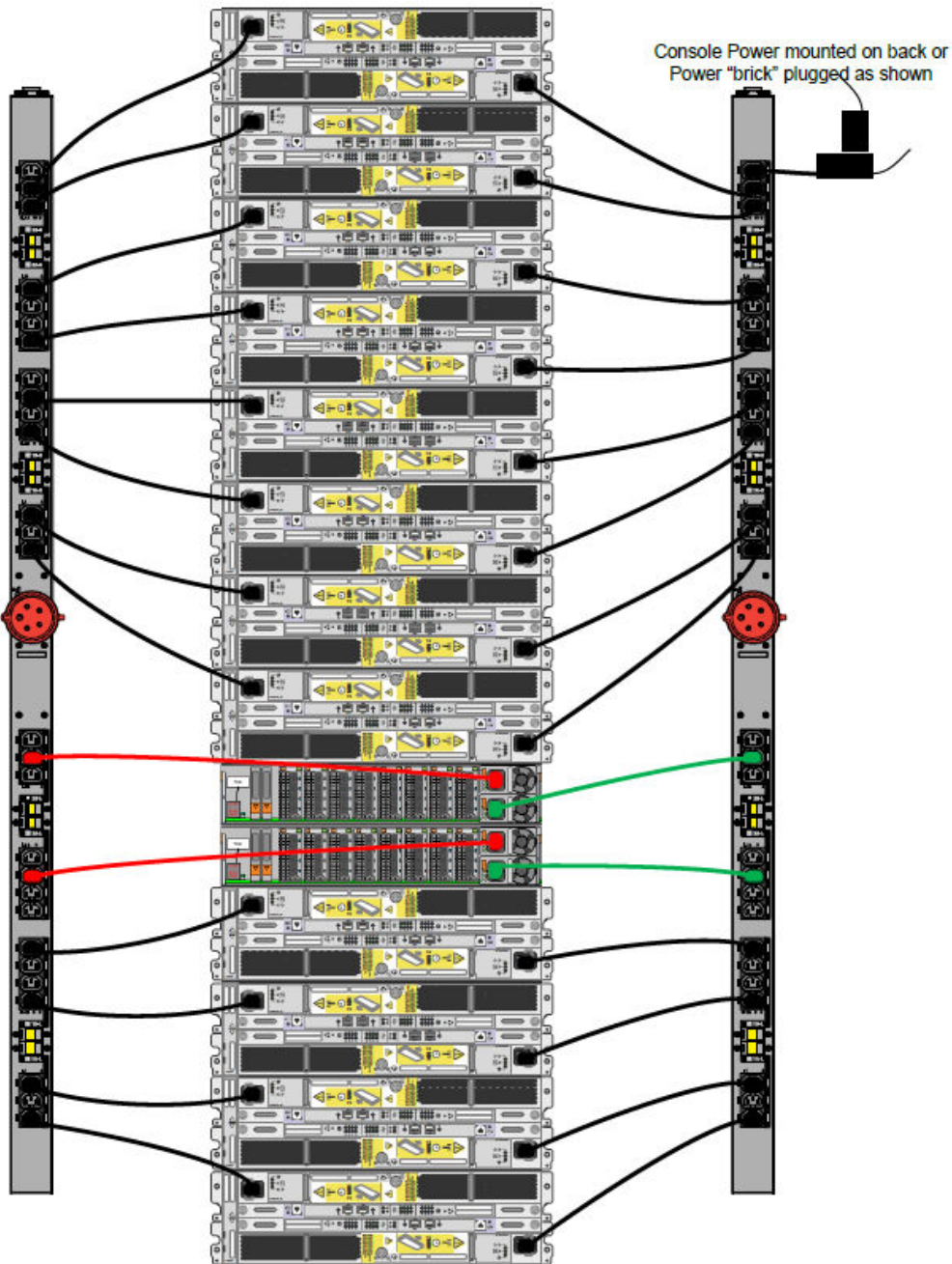


Figure 64 Recommended 3-phase wye power connections for DD6300, DD6800 and DD9300



**Figure 65** Recommended 3-phase wye power connections for DD9500/DD9800

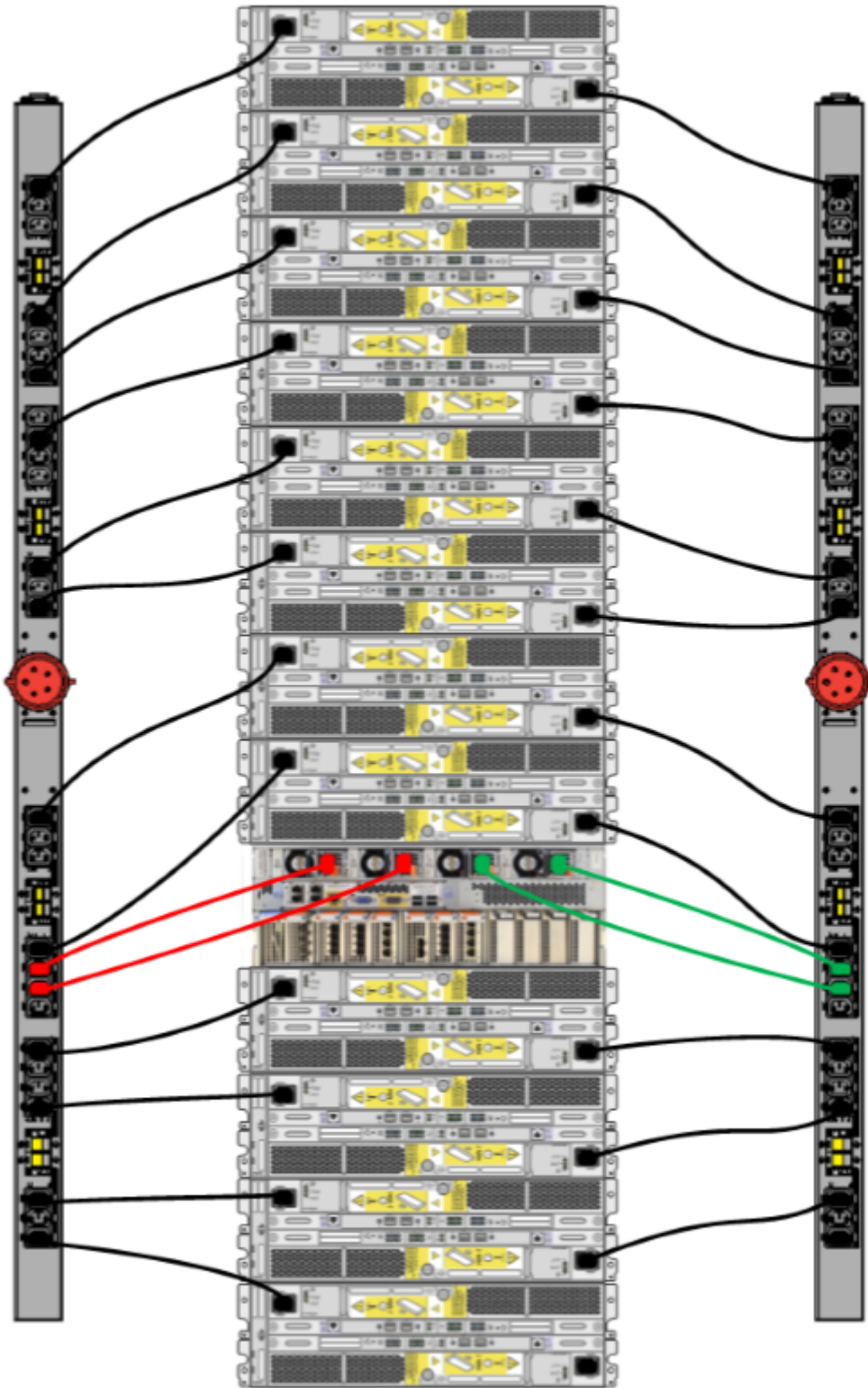
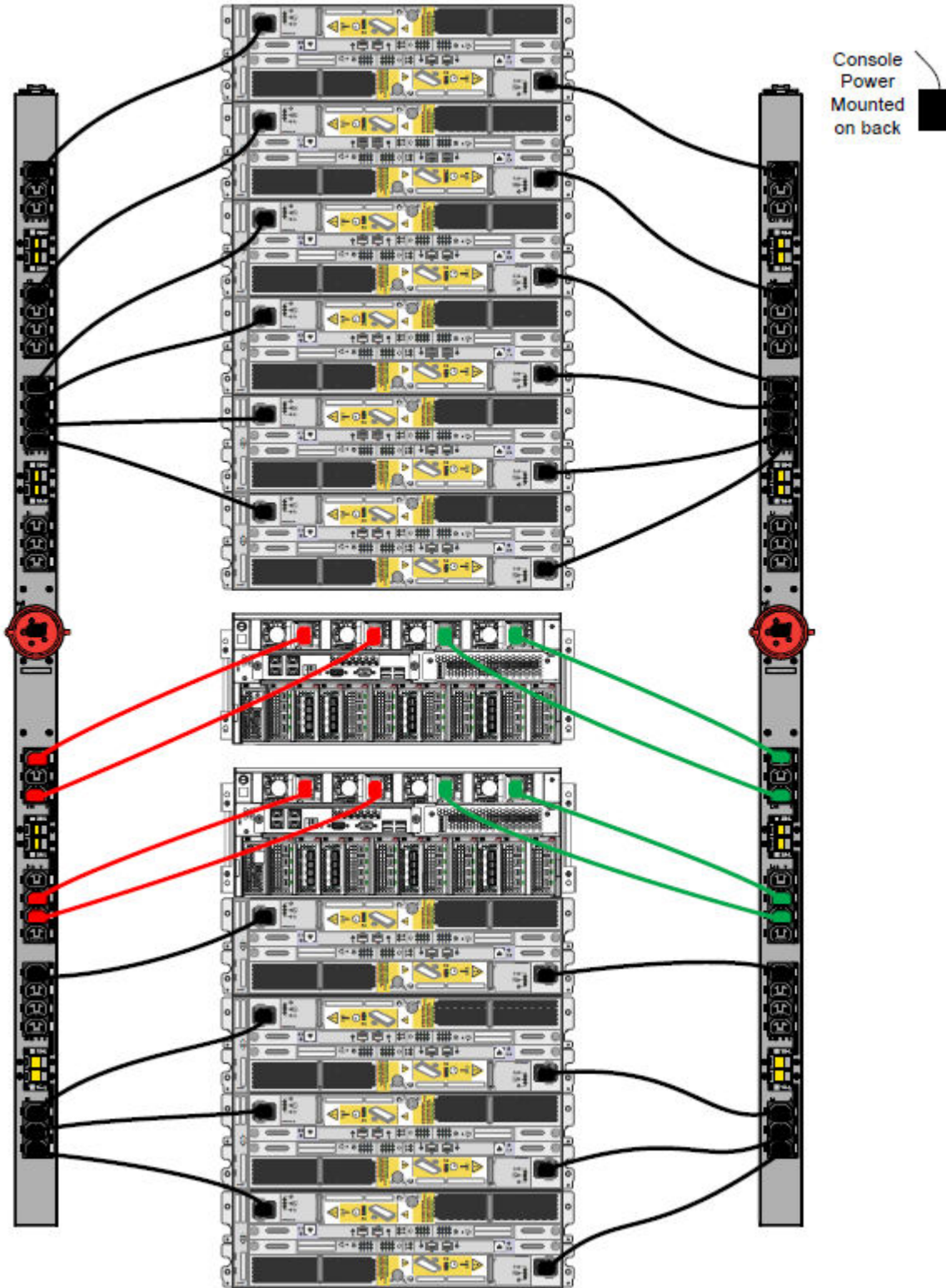




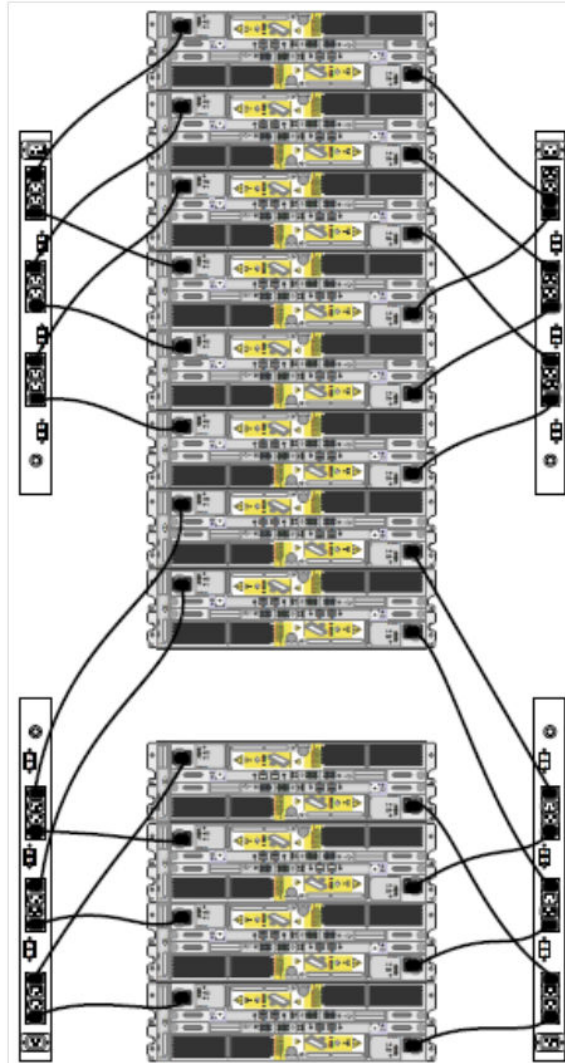
Figure 66 Recommended 3-phase wye power connections for DD9500/DD9800 HA



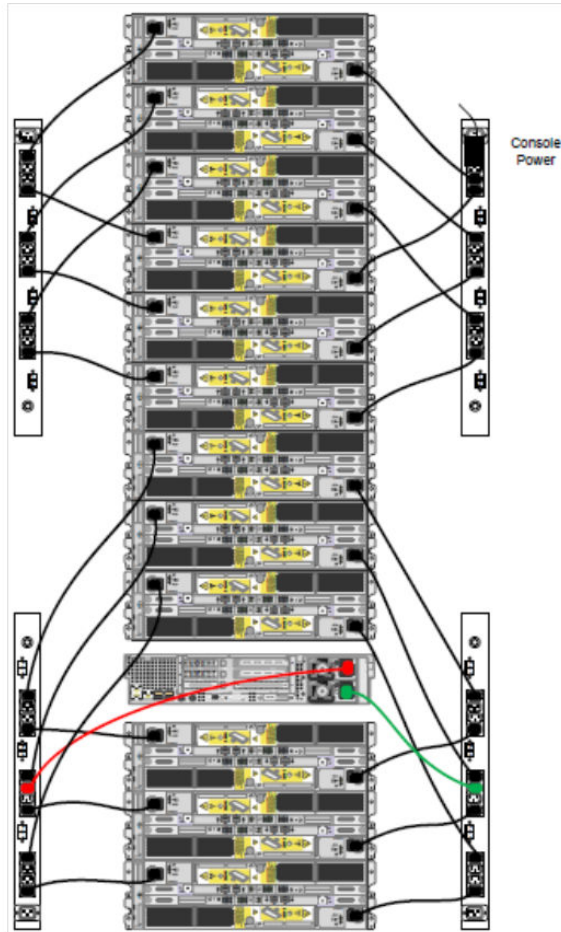
### 3-Phase power connections for 40U-C (older racks)

Some environments use 3-phase power for 40U-C racks used for several Data Domain systems. In those situations it is desirable to balance the current draw across all 3 phases. The recommended 3-phase power cabling attempts to do that, but an optimal configuration is dependent on the specific installation. The following figures show recommended 3-phase power connections for several Data Domain systems.

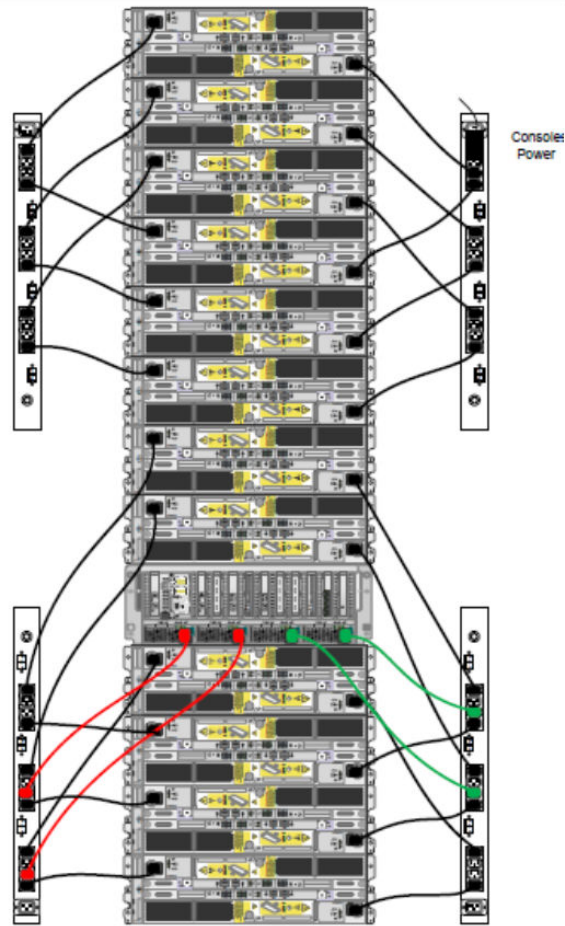
**Figure 67** Recommended 3-phase power connections for the Expansion Rack



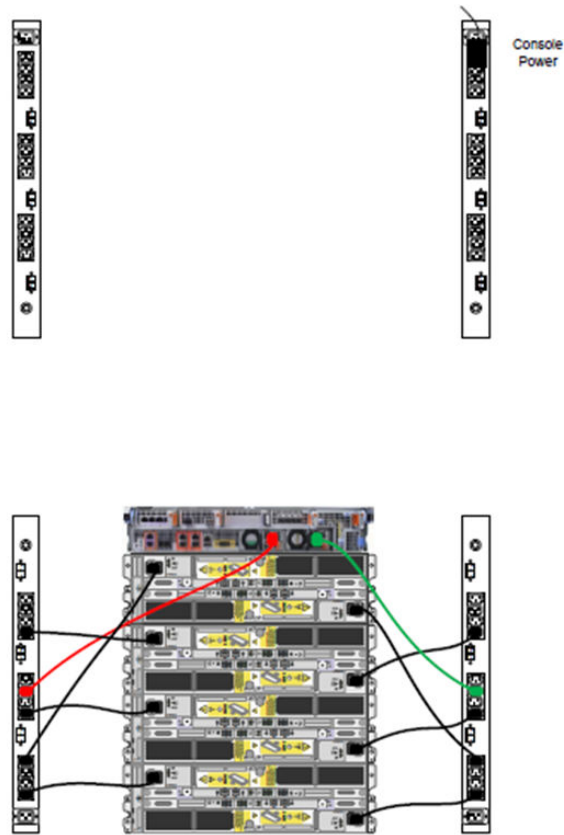
**Figure 68** Recommended 3-phase power connections for DD860 and DD890



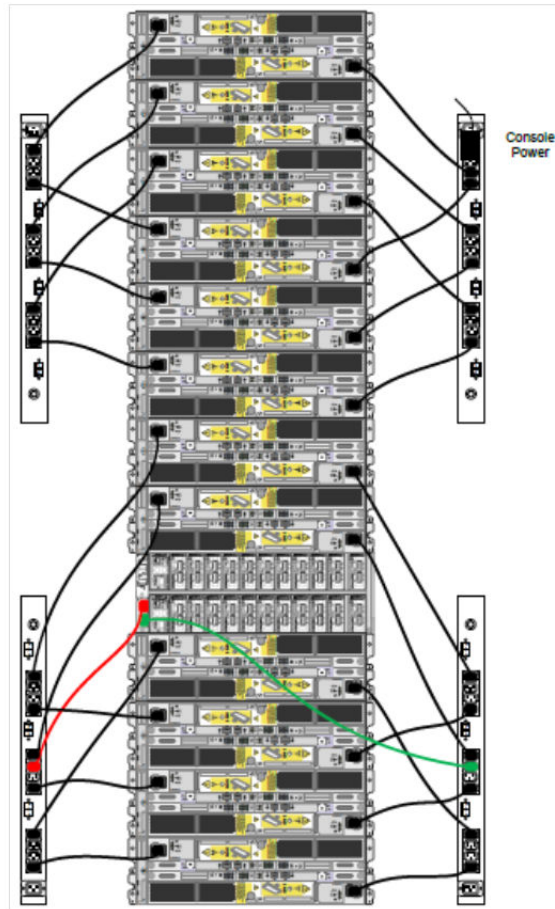
**Figure 69** Recommended 3-phase power connections for DD990



**Figure 70** Recommended 3-phase power connections for DD2500



**Figure 71** Recommended 3-phase power connections for DD4200, DD4500, and DD7200



# CHAPTER 3

## Data Domain-Specific Installation

This chapter shows the SAS HBA card and port location for each Data Domain system that supports the ES30 shelves. See the appropriate description for your DD system.

- [DD640, DD670, DD860, and DD890 systems](#)..... 112
- [DD660 and DD690 systems](#).....112
- [DD880 systems](#)..... 113
- [DD990 systems](#)..... 113
- [DD2500 systems](#)..... 114
- [DD4200, DD4500, and DD7200 systems](#)..... 114
- [DD6300, DD6800 and DD9300 systems](#).....115
- [DD9500 and DD9800 systems](#).....117

## DD640, DD670, DD860, and DD890 systems

### SAS HBA ports

The figure below shows the rear panel of these Data Domain systems with the location of PCI cards. SAS cards are installed in PCI slots 1, 2, and 3. Each SAS card has four ports (D, C, B, A). The ports are 1a, 1b, 1c, and 1d; 2a to 2d; and 3a to 3d.

Only the Data Domain DD860 controller with DD Extended Retention software (formerly called the DD860 Archiver) has three quad-port SAS cards installed. The other systems have two quad-port SAS cards.

Figure 72 DD640/670/860/890 rear panel

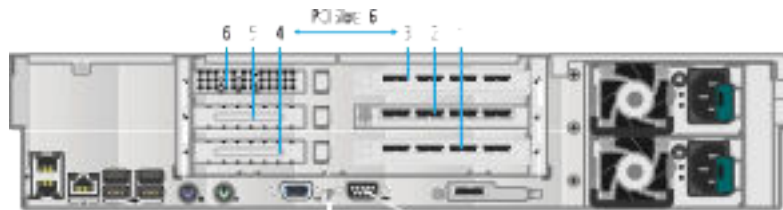
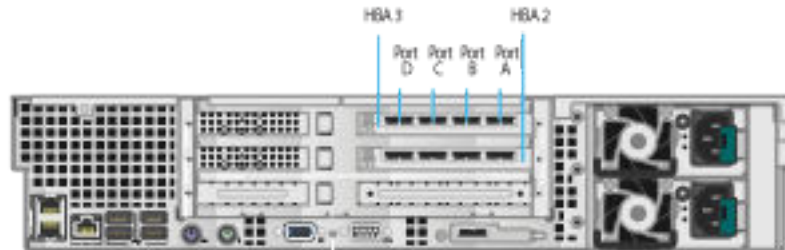


Figure 73 DD640/670/860/890 PCI slot numbering



## DD660 and DD690 systems

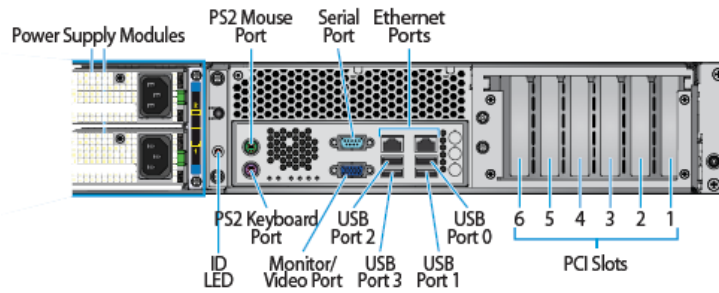
### Note

DD OS 5.7 and later releases do not support the DD660 and DD690 systems.

### SAS HBA ports

The SAS cards are located in PCI slot 4 (SAS # 1) and PCI slot 3 (SAS #2). Port A is located above Port B on each SAS card.



**Figure 74** DD660/DD690 rear panel

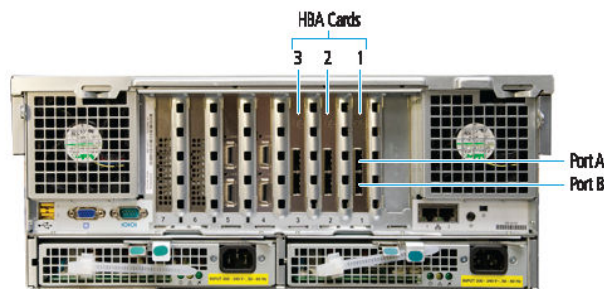
## DD880 systems

### Note

DD OS 5.7 and later releases do not support the DD880 systems.

DD880 systems have either two or three dual-port SAS cards installed. The ports are 1a, 1b; 2a, 2b; and 3a, 3b. See the table and associated information in [Shelf cabling rules and guidelines](#) on page 21 for configuration information.

### SAS HBA ports

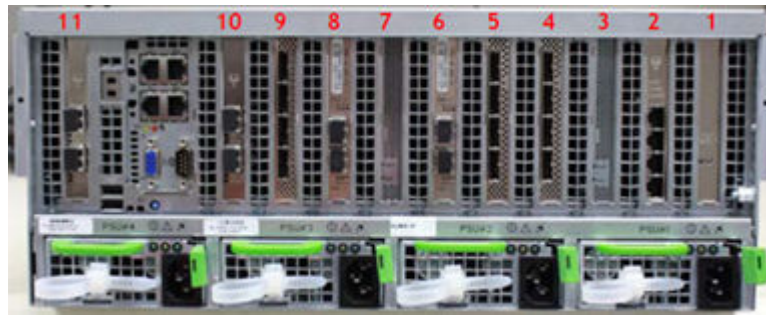
**Figure 75** DD880 rear panel

## DD990 systems

DD990 systems have three dual-port SAS cards installed (in slots 4, 5, or 9) and Extended Retention Systems for the DD990 have four dual-port SAS cards installed (in slots 4, 5, 8, or 9).

There are 11 HBA/PCI cards that are numbered 1-11 from right to left. On each card, the topmost port is "a", for example eth2a.

**Figure 76** DD990 back panel

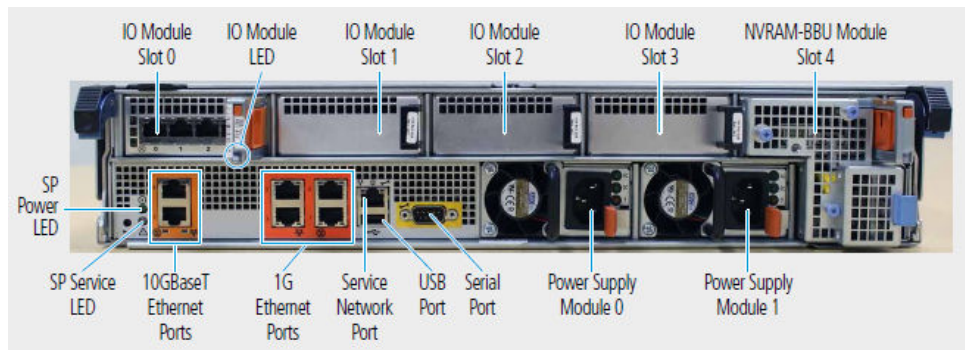


## DD2500 systems

DD2500 systems provide onboard interfaces located on the far lower left side when facing the back of the system. The onboard interfaces enable system status checks and connection to the system through a serial console or through Ethernet. A USB port is provided for use during service of the system to allow booting from a USB flash device.

A DD2500 system can contain up to 4 I/O modules including Fibre Channel, Ethernet and SAS. A SAS I/O module must be in slot 3 only.

**Figure 77** DD2500 back panel

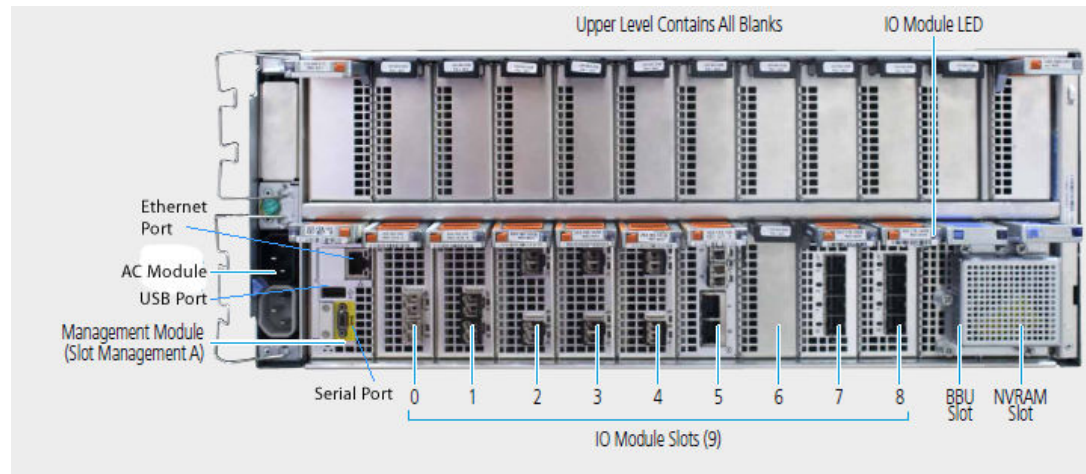


## DD4200, DD4500, and DD7200 systems

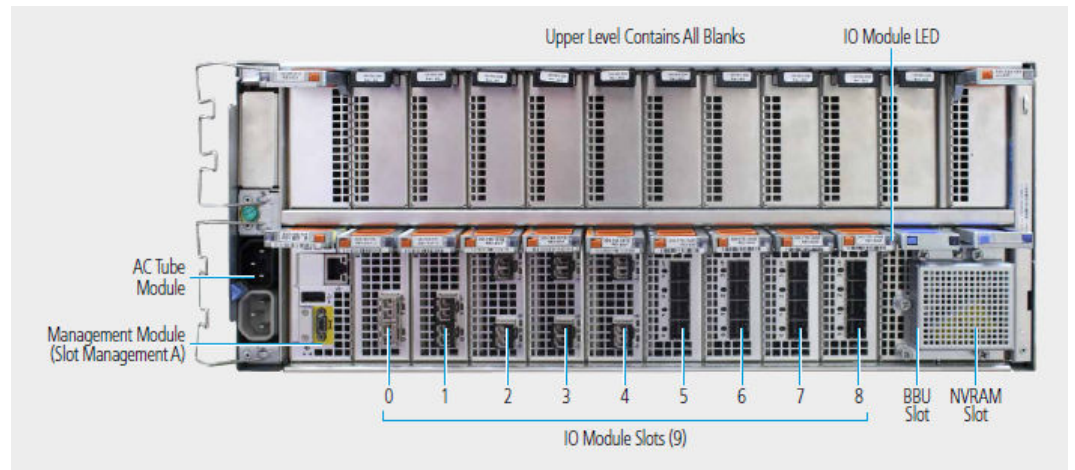
The management module is located on the far left side when facing the back of the system, in slot Management A. The management module contains one external LAN connection for management access to the system processor (SP) module. One micro DB-9 connector is included to provide the console. A USB port is provided for use during service of the system to allow booting from a USB flash device.

All systems contain 9 (0-8) available I/O module slots. Depending on the system, there can be up to 6 Ethernet modules, 4 Fibre Channel modules, or 4 SAS modules in a system.

For I/O modules containing multiple ports, the bottom port is numbered as zero (0) with numbers increasing going upward.

**Figure 78** Rear view (systems without Extended Retention software option or DD Cloud Tier)**Note**

Slots 7 and 8 are used for SAS I/O modules for systems without Extended Retention or DD Cloud Tier.

**Figure 79** Rear view (systems with Extended Retention software option or DD Cloud Tier)**Note**

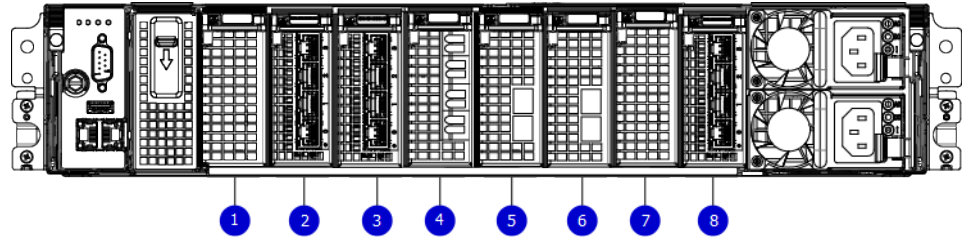
Slots 5 and 8 are used for SAS I/O modules for systems with Extended Retention or DD Cloud Tier.

## DD6300, DD6800 and DD9300 systems

DD6300, DD6800 and DD9300 Onboard IO is on the left of the rear side of the SP. A DB-9 port is used as a serial console, and a USB 2.0 compliant port is for performing DDOS upgrades. There are two 1000BaseT network port; the left port connects to a dedicated BMC service port, and the right port is a general purpose embedded 1GBE host interface port .

DD6300, DD6800 and DD9300 have eight SLIC slots (0-7) and are 8-lane PCIe Gen3 with an assigned specific functionality. The non-optional SAS, NVRAM, and 10GBaseT SLICs are allocated to fixed slots. The optional Host Interface SLICs are used for front end networking and fibre channel connections.

**Figure 80** Rear view and SLIC slot numbering



1. Slot 0
2. Slot 1
3. Slot 2
4. Slot 3
5. Slot 4
6. Slot 5
7. Slot 6
8. Slot 7

**Note**

Slots 2 and 7 are used for SAS I/O modules. DD6300 systems use only slot 7 when the SAS module is needed.

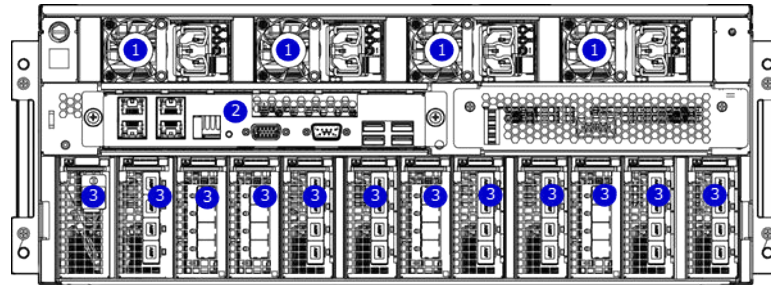
**Table 26** DD6300, DD6800 and DD9300 I/O module slot assignments

Slot Number	DD6300	DD6800	DD9300
0	NVRAM	NVRAM	NVRAM
1	10GbE	10GbE	10GbE
2	Reserved	SAS	SAS
3	SAS	SAS	SAS
4	FC, Ethernet or empty	FC, Ethernet or empty	FC, Ethernet or empty
5	FC, Ethernet or empty	FC, Ethernet or empty	FC, Ethernet or empty
6	FC, Ethernet or empty	FC, Ethernet or empty	FC, Ethernet or empty
7	Empty	SAS	SAS

## DD9500 and DD9800 systems

In the rear of the system, the top section contains the 4 power supply units. In the middle of the section, on the left, is serial number tag location. To the right of the serial number tag location is the management module. The lower section contains the NVRAM and the I/O modules numbered 0 through 11 from left to right.

**Figure 81** Rear of the DD9500 and DD9800 system

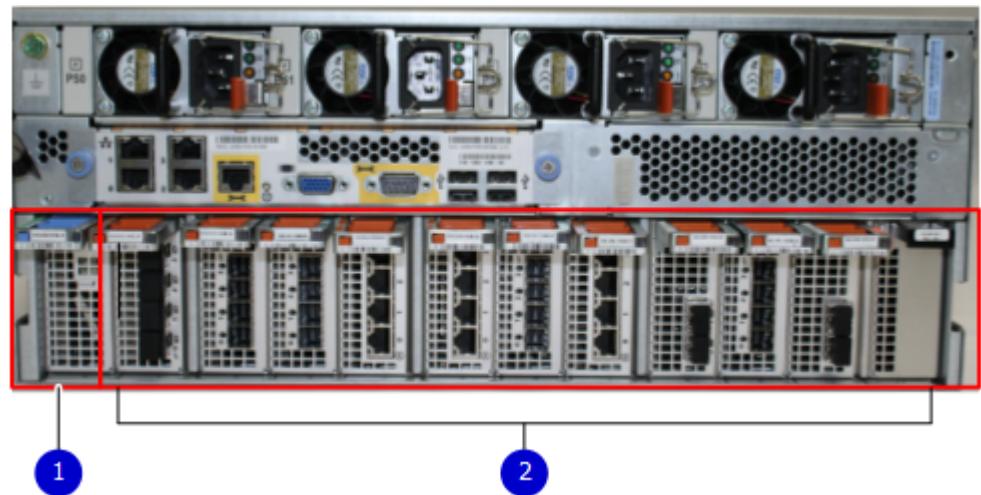


1. Power supply units
2. Management module
3. NVRAM and I/O modules (slots 0-11)

## I/O module slot assignments

The following figure shows the location of the NVRAM and I/O modules.

**Figure 82** Location of NVRAM and I/O modules



1. NVRAM module—slot 0
2. I/O modules—slots 1 to 11 (See the I/O module slot assignments table.)

---

### Note

Slots 2, 3, and 6 (three I/O slots) are used for SAS I/O modules for systems without Extended Retention (ER).

---

**Figure 82** Location of NVRAM and I/O modules (continued)**Note**

Slots 2, 3, 6, and 9 (four I/O slots) are for SAS I/O modules for systems with ER or DD Cloud Tier software.

The table shows the I/O module slot assignments for the DD9500 and DD9800 systems. Each type of I/O module is restricted to certain slots.

The I/O module slot assignments for the DD9500 and DD9800 systems are the same.

**Table 27** DD9500 and DD9800 I/O module slot assignments

Slot	Base configuration	HA	ER or DD Cloud Tier	DD Cloud Tier and HA
0	NVRAM	NVRAM	NVRAM	NVRAM
1	Fibre Channel (FC), Ethernet or empty	Fibre Channel (FC), Ethernet or empty	Fibre Channel (FC), Ethernet or empty	Fibre Channel (FC), Ethernet or empty
2	SAS	SAS	SAS	SAS
3	SAS	SAS	SAS	SAS
4	FC, Ethernet or empty	FC, Ethernet or empty	FC, Ethernet or empty	FC, Ethernet or empty
5	FC, Ethernet or empty	FC, Ethernet or empty	FC, Ethernet or empty	FC, Ethernet or empty
6	SAS	SAS	SAS	SAS
7	FC, Ethernet or empty	FC, Ethernet or empty	FC, Ethernet or empty	FC, Ethernet or empty
8	FC, Ethernet or empty	FC, Ethernet or empty	FC, Ethernet or empty	FC, Ethernet or empty
9	Not available (contains a filler)	Not available (contains a filler)	SAS	SAS
10	FC, Ethernet or empty	FC, Ethernet or empty	FC, Ethernet or empty	FC, Ethernet or empty
11	FC, Ethernet or empty	10 Gb optical Ethernet for interconnect between the primary and standby nodes in the HA pair.	FC, Ethernet or empty	10 Gb optical Ethernet for interconnect between the primary and standby nodes in the HA pair.

# CHAPTER 4

## Post-Installation Tasks

After you have installed and cabled the shelves in their racks, follow the instructions in this chapter to complete the setup. This chapter covers these major topics:

- [Add shelf capacity licenses](#)..... 120
- [Power on sequence](#)..... 121
- [Verifying shelf installation](#)..... 123
- [Add enclosure disks to the volume](#)..... 126

## Add shelf capacity licenses

Apply appropriate shelf capacity licenses for all shelves as needed. Some legacy ES20 shelves may not require shelf capacity licenses.

## Add storage license

Each storage shelf requires a shelf capacity license. This license is specific for either active or Extended Retention tier usage of the shelf. Only the DD Extended Retention for DD990 system has an Extended Retention tier.

---

### Note

DD6300, DD6800 and DD9300, and DD9800 systems can only be licensed through the Electronic Licensing and Management System (ELMS). Refer to the applicable *Data Domain Operating System Release Notes* for the most up-to-date information on product features, software updates, software compatibility guides, and information about Data Domain products, licensing, and service.

An Expanded-Storage license is required when expanding the capacity of the active tier beyond the entry capacity. Please check system documentation to determine if the Expanded-Storage license is required.

### Procedure

1. To add shelf capacity licenses, enter the `license add` command followed by one or more license keys, separated with a space. For example:

```
# license add Capacity-Active {license}
```

2. Issue the `storage add tier` command once for each enclosure that is to be added to a tier. For example, for a standard Data Domain system:

```
# storage add tier active enclosure enclosure-id
```

For a Data Domain system with Extended Retention:

```
# storage add tier archive enclosure enclosure-id
```

For a Data Domain system with Cloud Tier:

```
# storage add tier cloud enclosure enclosure-id
```

For a Data Domain system with Cache:

```
# storage add tier cache enclosure enclosure-id
```

---

### Note

In a single-node Data Domain system, storage devices are added to the active tier by default. In a DD Extended Retention system, you must specify the active or archive tier.

Specifying an *enclosure-id* makes all disks in the enclosure available to the tier. This is the preferred method of adding storage to a Data Domain system. To use this option, all disks in the enclosure must be in the unknown state.

---



## Power on sequence

The ES30 shelf does not have a power-on button. The power cable must be connected to a live power source in order for a shelf to be powered on.

### Connect power to shelves

---

#### Note

The Data Domain system re-discovers newly configured shelves after it restarts but the power cables need to be connected to a live power source to power a shelf.

---

#### Procedure

1. With the main power source off, connect an AC power cord (included with the shelf) to the shelf's power connector.
2. Secure the power cord with the retention bails at each connection. The bails prevent the power cord from pulling out of the connections.
3. Repeat for each of the shelves.
4. Turn on the power source. When a shelf is powered on and functioning properly:
  - The shelf's power LED is green.
  - Each Controller's power LED is green.
5. Verify that there are no amber (fault) LEDs.
  - If the Power Supply Fault LED is steady amber, the power supply is faulty or is not receiving AC line voltage. If it is flashing, either a multiple blower or ambient over-temperature condition has shut off DC power to the system.
  - If the Controller Fault LED is amber, either the Controller or SAS connection is faulty.
    - a. If there are amber LEDs, reseal or replace the power cable and check the LEDs again.
    - b. Reseat the SAS cables. If there is still a problem, use different SAS cables.
    - c. Reseat the Controller module.
    - d. If the connection still has a problem, you need to replace the controller module on either or both ends of the connection. The shelf controller module B is placed above controller module A. See the next figure.

**Figure 83** Back panel: Identical shelf controllers (controller B above controller A)



1. Controller and power supply B
2. LEDs for power supply B
3. Controller and power supply A
4. LEDs for power supply A

**Note**

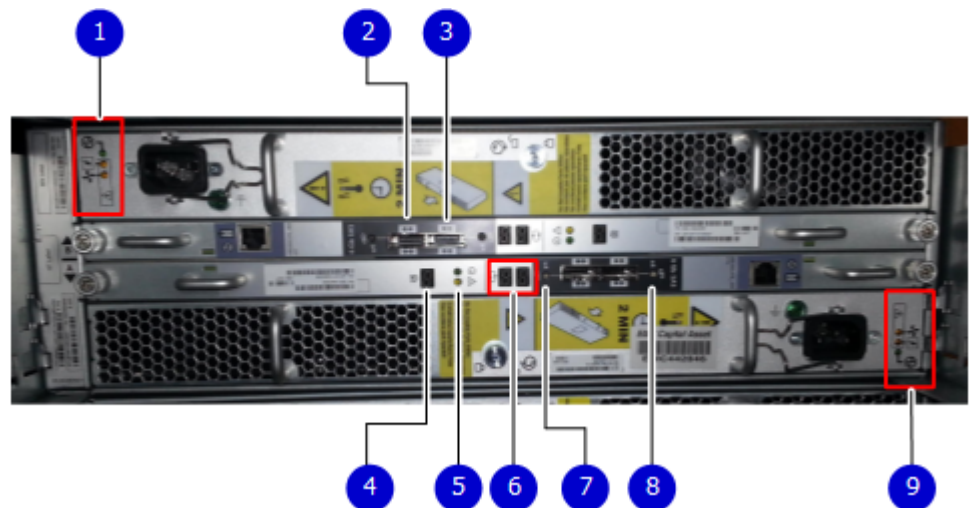
When replacing a component, note its orientation when removing it. Insert the replacement in the same position.

**Note**

The power supplies of controller A is located at the top of the shelf and the power supply of controller B is located at the bottom of the shelf.

6. If there are no amber LEDs, wait a few minutes after the final shelf was powered on before restarting the Data Domain system.

**Figure 84** Back panel: Power modules (controller B above controller A)



1. LEDs: Power Supply B: Power LED, Power fault: Amber, Blower fault: Amber

2. Expansion (Out), on Controller B
  3. Host (In), on Controller B
  4. Enclosure address, on Controller A (not used)
  5. Power (Green) or Fault (Amber), on Controller A
  6. Bus ID, on Controller A
  7. Host link active, on Controller A
  8. Expansion link active, on Controller A
  9. LEDs: Controller A: Power LED, Power fault: Amber, Blower fault: Amber
7. Restart the Data Domain system. As the system boots up, the HOST/ EXPANSION LEDs on the shelf controller ports that are connected to the SAS HBAs in the Data Domain system change from off to blue or green (see LED information in [Back panel: Power/cooling module and shelf controllers](#) on page 13).

If any of these LEDs stays off or is not running at normal speed (see the table in [Back panel: Power/cooling module and shelf controllers](#) on page 13), it means there is a problem in the connection between the system and the shelf. Reseat or replace the cable and check the LEDs again. If the connection still has a problem, replace the controller module or the SAS HBA.

## Verifying shelf installation

The Data Domain system recognizes all data storage (system and attached shelves) as part of a single file system volume.

### **⚠ WARNING**

- **Do not remove or disconnect a shelf that has been added earlier. If a shelf is disconnected, the file system volume is immediately disabled and all data in the volume is lost.**
- **To re-enable a shelf, reconnect the shelf or transfer the disks from the shelf to another empty shelf chassis and connect.**
- **If the data on a shelf is not available to the file system volume, the volume cannot be recovered.**
- **Unless the same disks are available to the file system, the DD OS must be re-installed as directed by your contracted service provider or the Online Support site, <http://support.emc.com>.**

### Procedure

1. After installing the new shelves, check the status of the SAS HBA cards by entering the `disk port show summary` command:

```
# disk port show summary
Port      Connection  Link      Connected  Status
          Type       Speed     Enclosure  IDs
-----
2a        SAS         12 Gbps   4          online
2b        SAS                    offline
2c        SAS                    offline
2d        SAS                    offline
3a        SAS         24 Gbps   2          online
3b        SAS                    offline
3c        SAS                    offline
3d        SAS                    offline
```

```

6a    SAS           12 Gbps   4           online
6b    SAS           12 Gbps   4           offline
6c    SAS           24 Gbps   3           online
6d    SAS           24 Gbps   3           offline
9a    SAS           12 Gbps   4           offline
9b    SAS           12 Gbps   4           offline
9c    SAS           12 Gbps   4           offline
9d    SAS           24 Gbps   2           online
-----

```

The output shows:

- The **online** status for each SAS connection, such as 2a, 3a, 6a
- The **offline** status for each SAS connection, such as 2b, 3b, 6b
- After the shelves have been connected, the same command also displays the connected enclosure IDs for each port. The status changes to **online**.

2. After adding any enclosure/shelf, enter the `disk show state` command to verify the disk state.

```

# disk show state
Enclosure  Disk
-----
1          1  2  3  4  5  6  7  8  9  10 11 12 13 14 15
-----
1          .  .  .  .
2          U  U  U  U  U  U  U  U  U  U  U  U  U  U  U
3          s  U  U  U  U  U  U  U  U  U  U  U  U  U  F
4          U  U  U  U  U  U  U  U  U  U  U  U  U  U  U
5          A  K  v  K  K  K  K  K  K  v  K  K  K  K  R
-----

Legend     State                                     Count
-----
.          In Use Disks                               4
s          Spare Disks                               1
R          Spare (reconstructing) Disks              1
v          Available Disks                           2
K          Known Disks                               11
U          Unknown Disks                             43
F          Failed Disks                               1
A          Absent Disks                               1
-----

Total 64 disks

```

**Note**

Run the `storage add` command to add disks in the **U** state to the Data Domain system.

3. Verify that the Data Domain system recognizes each attached enclosure/shelf by entering the `enclosure show summary` command:

```

# enclosure show summary
Enclosure  Model No.  Serial No.  State  OEM Name  OEM Value  Capacity
-----
1          DD9500    NVT10133200020  Online  ES30    APM00133825711  15 Slots
2          ES30     APM00120900626  Online  ES30    APM00123706119  15 Slots
3          ES30     APM00133825239  Online  ES30    APM00133825239  15 Slots
4          ES30     APM00133825239  Online  ES30    APM00133825239  15 Slots
5          ES30     APM00133825239  Online  ES30    APM00133825239  15 Slots
-----
5 enclosures present.

```

The output shows each recognized enclosure ID, Data Domain system model number, serial number, and slot capacity.

- To verify that the system is in good running condition and shows no errors, enter the enclosure show topology command:

```
# enclosure show topology
Port      enc.ctrl.port      enc.ctrl.port      enc.ctrl.port
-----
2a
2b > 2.B.H: 2.B.E > 3.B.H: 3.B.E > 4.B.H: 4.B.E
2c > 5.B.H: 5.B.E
2d
3a > 5.A.H: 5.A.E
3b
3c > 4.A.H: 4.A.E > 3.A.H: 3.A.E > 2.A.H: 2.A.E
3d
-----
Encl      WWN                Serial #
-----
2         N/A                APM00134300550
3         N/A                APM00134300549
4         N/A                APM00134300556
5         N/A                APM00134300555
-----

Error Message:
-----
No error detected
-----

ES20 rear view:
                CONTROLLER-B  CONTROLLER-A  OP-PANEL
+-----+
|         |         E         |         H         |         | |
|         |         |         |         |         |
|         |         H         |         E         |         |
+-----+

ES30 rear view:
+-----+
CONTROLLER-B |         E
H
+-----+
+-----+
CONTROLLER-A |         H
E
+-----+
```

- Run the enclosure test topology command to validate SAS cable connections.

```
# enclosure test topology 2b:2.B.H duration 1
HBA Information:
-----
#      Port Name      ChipType      Firmware
2b     ioc0            MoonLite      2134500
-----

Date and time:
Tue Sep 20 14:16:24 2016
-----

Timestamp:
1474406184
-----

Port      enc.ctrl.port
-----
2a > 2.B.H:2.B.E
-----
```

```

Error message:
-----
No error detected
-----
Execute command:
/DDR/bin/devperf --direct-io --loop --nolock --test-len 60 r 2m
400g 1 /dev/sdaj /dev/sdaf /dev/sdah /dev/sdal /dev/sdas /dev/
sdau /dev/sdan /dev/sdao /dev/sdaq /dev/sdav /dev/sdbd /dev/
sdbl /dev/sday /dev/sdbb /dev/sdbj /dev/sdbf /dev/sdbh /dev/
sdbv /dev/sdbw /dev/sdbp /dev/sdbn /dev/sdbz /dev/sdbt /dev/
sdbq /dev/sdci /dev/sdcg /dev/sdca /dev/sdce /dev/sdcc /dev/
sdcn /dev/sdck /dev/sdcq /dev/sdcm /dev/sdcr /dev/sdct /dev/
sdcv /dev/sdcw /dev/sdcx /dev/sddu /dev/sdcy /dev/sddc /dev/
sdcz /dev/sdda /dev/sddf /dev/sddg /dev/sddd /dev/sdde /dev/
sddh /dev/sddk /dev/sddi /dev/sddj /dev/sddn /dev/sddl /dev/
sddm /dev/sddo /dev/sddp /dev/sddr /dev/sddq /dev/sdds /dev/
sdtd > /tmp/devperf_log 2>&1

Started: 1474406184
Ended: 1474406246
Duration: 62

Date and time:
Tue Sep 20 14:17:26 2016
-----
Timestamp:
1474406246
-----
Port          enc.ctrl.port
-----
2b          >    2.B.H:2.B.E
-----
Error message:
-----
No error detected
-----

```

## Add enclosure disks to the volume

### Procedure

1. When prompted, enter your sysadmin password.
2. Enter the storage show all command to display the RAID groups for each shelf:

```

# storage show all
Active tier details:
Disk          Disks          Count  Disk          Additional
Group                                     Size    Information
-----
dg1           5.1-5.14          14     3.6 TiB
dg3           2.4-2.6, 2.16-2.18, 2.28-2.30, 14     2.7 TiB
              2.40-2.42, 2.53-2.54
dg4           4.1-4.14          14     1.8 TiB
dg5           6.1-6.14          14     1.8 TiB
(spare)       2.52              1     2.7 TiB
(spare)       5.15              1     3.6 TiB
(available)   4.15              1     1.8 TiB
(available)   6.15              1     1.8 TiB
-----

Current active tier size: 120.0 TiB
Active tier maximum capacity: 261.9 TiB

Storage addable disks:
Disk          Disks          Count  Disk          Enclosure  Shelf Capacity
Additional                                     Type        Size        Model        License Needed
-----

```

```

Information
-----
(unknown) 2.1-2.3, 2.13-2.15, 2.25-2.27, 15 2.7 TiB DS60 32.7 TiB
pack 1
(unknown) 2.37-2.39, 2.49-2.51
pack 3 2.7-2.9, 2.19-2.21, 2.31-2.33, 15 2.7 TiB DS60 32.7 TiB
(unknown) 2.43-2.45, 2.55-2.57
pack 4 2.10-2.12, 2.22-2.24, 2.34-2.36, 15 2.7 TiB DS60 32.7 TiB
(unknown) 2.46-2.48, 2.58-2.60
pack 1 3.1-3.3, 3.13-3.15, 3.25-3.27, 15 2.7 TiB DS60 32.7 TiB
(unknown) 3.37-3.39, 3.49-3.51
pack 2 3.4-3.6, 3.16-3.18, 3.28-3.30, 15 2.7 TiB DS60 32.7 TiB
(unknown) 3.40-3.42, 3.52-3.54
pack 3 3.7-3.9, 3.19-3.21, 3.31-3.33, 15 2.7 TiB DS60 32.7 TiB
(unknown) 3.43-3.45, 3.55-3.57
pack 4 3.10-3.12, 3.22-3.24, 3.34-3.36, 15 2.7 TiB DS60 32.7 TiB
3.46-3.48, 3.58-3.60
-----

Shelf Capacity License:
License Model Total Used Remaining
-----
CAPACITY-ACTIVE ES30 109.1 TiB 87.3 TiB 21.8 TiB
CAPACITY-ACTIVE DS60 152.7 TiB 32.7 TiB 120.0 TiB
-----

```

One disk in a shelf is a spare disk. The rest should report that they are available.

3. Enter the `filesys expand` command to allow the file system to use these enclosure disks:

```
# filesys expand
```

4. Enter the `filesys enable` command to enable the file system:

```
# filesys enable
```

5. Enter the `disk show state` command to verify the disks:

```
# disk show state
Enclosure Disk
Row(disk-id) 1 2 3 4 5 6 7 8 9 10 11 12 13 14 15
-----
1
2
3
|-----|-----|-----|-----|
| Pack 1 | Pack 2 | Pack 3 | Pack 4 |
E(49-60) |v v v |v v v |v v v |v v v |
D(37-48) |v v v |v v v |v v v |v v v |
C(25-36) |v v v |v v v |v v v |v v v |
B(13-24) |v v v |v v v |v v v |v v v |
A( 1-12) |v v v |v v v |v v v |v v v |
|-----|-----|-----|-----|
4
|-----|-----|-----|-----|
| Pack 1 | Pack 2 | Pack 3 | Pack 4 |
E(49-60) |U U U |U U U |U U U |U U U |
D(37-48) |U U U |U U U |U U U |U U U |
C(25-36) |U U U |U U U |U U U |U U U |
B(13-24) |U U U |U U U |U U U |U U U |
A( 1-12) |U U U |U U U |U U U |U U U |

```

## Post-Installation Tasks

```
----- |-----|-----|-----|-----|
Legend   State           Count
-----  -
.        In Use Disks         3
v        Available Disks 60
U        Unknown Disks  75
-----  -
Total 138 disks
```



# APPENDIX A

## Hardware Specifications

This appendix contains the following topics:

- [ES30 and FS15 hardware specifications](#)..... 130

## ES30 and FS15 hardware specifications

### Note

All ratings assume a fully configured ES30 or FS15.

**Table 28** ES30 and FS15 hardware specifications

Specification	Description
AC line voltage	100 to 240 Vac $\pm$ 10%, single-phase, 47 to 63 Hz
AC line current (operating maximum)	2.8 A max at 100 Vac, 1.4 A max at 200 Vac
Power consumption (operating maximum)	280 VA (235 W) max
Power factor	0.98 min at full load, low voltage
Heat dissipation (operating maximum)	$8.46 \times 10^5$ J/hr, (800 Btu/hr) max
Dimensions (rack mounted, with bezel)	<ul style="list-style-type: none"> <li>Width: 17.62" (45 cm) Depth: 14" (35.56cm)</li> <li>Height: 5.25" (13.34cm) 3 RU</li> </ul>
Maximum Weight	68 lbs (30.8 kg)
Operating Temperature	<ul style="list-style-type: none"> <li>Ambient temperature: 10° C to 35° C (50° F to 95° F)</li> <li>Temperature gradient: 10° C/hr (180° F/hr)</li> <li>Relative humidity extremes: 20% to 80% noncondensing</li> </ul>
Recommended Operating Relative Humidity	40% to 55% noncondensing
Non-Operating Temperature	<ul style="list-style-type: none"> <li>Ambient temperature: -40° C to 65° C (-40° F to 149° F)</li> <li>Temperature gradient: 25° C/hr (45° F/hr)</li> <li>Relative humidity: 10% to 90% noncondensing</li> </ul>